

Technical Support Center: Eniclobrate & Cell Culture Applications

Author: BenchChem Technical Support Team. **Date:** May 2026

Compound of Interest

Compound Name: *Eniclobrate*

CAS No.: 60662-18-2

Cat. No.: B10781295

[Get Quote](#)

A Guide to Differentiating On-Target vs. Off-Target Effects

Welcome, researchers, to the technical support center for **Eniclobrate**. As Senior Application Scientists, we understand that using small molecule probes in cell culture is both a powerful and nuanced endeavor. This guide is designed with full editorial control to provide you with in-depth, field-proven insights to troubleshoot and validate your experiments with **Eniclobrate**, ensuring the scientific integrity of your results. We will move beyond simple protocols to explain the "why" behind each experimental choice, empowering you to generate robust and reliable data.

Section 1: Understanding Eniclobrate - On-Target Action and Off-Target Potential

This section provides foundational knowledge about **Eniclobrate**'s mechanism of action and the general principles of off-target effects.

Q1: What is the primary molecular target and mechanism of action for **Eniclobrate**?

A: **Eniclobrate** belongs to the fibrate class of drugs, which are well-established as agonists for the Peroxisome Proliferator-Activated Receptor Alpha (PPAR α).^{[1][2]} PPAR α is a ligand-activated transcription factor that plays a crucial role in regulating the expression of genes involved in lipid metabolism and inflammation.^{[1][3]}

Upon entering the cell, **Eniclobrate** binds to the Ligand-Binding Domain (LBD) of PPAR α . This binding event induces a conformational change in the receptor, causing it to form a heterodimer with another nuclear receptor, the Retinoid X Receptor (RXR). This PPAR α -RXR complex then binds to specific DNA sequences known as Peroxisome Proliferator Response Elements (PPREs) located in the promoter regions of target genes.^[2] This binding recruits coactivator proteins, initiating the transcription of genes that govern fatty acid uptake, transport, and catabolism.^[1] A secondary, on-target effect is the transrepression of inflammatory signaling pathways, such as NF- κ B.^{[4][5]}

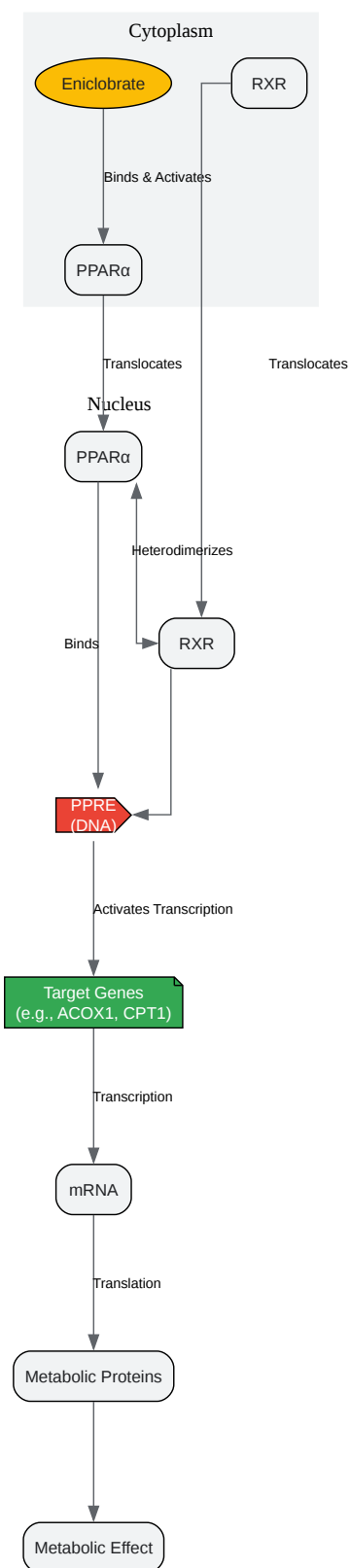

[Click to download full resolution via product page](#)

Figure 1. Simplified PPARα signaling pathway activated by **Eniclobrate**.

Q2: I'm observing a phenotype in my cells that doesn't seem related to lipid metabolism. Could this be an off-target effect?

A: Yes, it is a distinct possibility. While **Eniclobrate**'s primary target is PPAR α , no small molecule inhibitor is perfectly specific.[6] Off-target effects occur when a compound interacts with unintended biological molecules, leading to unforeseen consequences.[7] For the fibrate class, several PPAR α -independent effects have been documented. For instance, studies using Ppara-null mice have shown that fibrates like fenofibrate can still influence metabolic pathways, partly through the inhibition of STAT3 signaling.[8][9]

Therefore, if you observe effects such as unexpected changes in cell proliferation, apoptosis, or signaling pathways unrelated to PPAR α , it is crucial to perform validation experiments to determine if these are bona fide on-target effects or a result of off-target interactions.

Section 2: The Troubleshooting Workflow: A Step-by-Step Guide to Validation

If you suspect an off-target effect, or simply want to practice good scientific rigor, follow this validation workflow. Each step provides increasing confidence in attributing your observed phenotype to the on-target action of **Eniclobrate**.

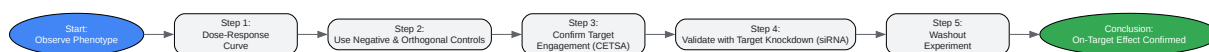

[Click to download full resolution via product page](#)

Figure 2. Experimental workflow for validating **Eniclobrate**'s effects.

Step 1: Generate a Dose-Response Curve

Q3: Why is a dose-response curve the first step, and how do I set it up?

A: A dose-response experiment is fundamental to understanding the potency of **Eniclobrate** for your specific phenotype.[10] It allows you to determine the concentration at which you see a

half-maximal effect (EC50 for an agonist). An on-target effect should typically occur within a consistent and potent dose range.^[11] If the effect you're observing only happens at very high concentrations, it increases the likelihood of it being an off-target phenomenon.

Experimental Protocol: Dose-Response for IC50/EC50 Determination

- **Cell Seeding:** Plate your cells in a multi-well plate (e.g., 96-well) at a density that ensures they are in the logarithmic growth phase for the duration of the experiment.
- **Compound Preparation:** Prepare a serial dilution of **Eniclobrate**. A common approach is to use 8 to 10 concentrations, spanning a wide range (e.g., from 1 nM to 100 μ M). Always include a vehicle-only control (e.g., DMSO).
- **Treatment:** After allowing cells to adhere (typically overnight), replace the media with fresh media containing the different concentrations of **Eniclobrate** or vehicle.
- **Incubation:** Incubate the cells for a period relevant to your observed phenotype (e.g., 24, 48, or 72 hours).
- **Assay Readout:** Use an appropriate assay to measure your phenotype. For cell viability, common methods include MTT or resazurin-based assays. For gene expression, you would proceed to RNA extraction and qPCR.
- **Data Analysis:**
 - Normalize your data. For an inhibitory effect, set the vehicle control as 100% viability and a "no cells" or "maximum inhibition" control as 0%.^[12]
 - Plot the response against the log of the **Eniclobrate** concentration.
 - Fit the data using a non-linear regression model (e.g., a four-parameter logistic curve) to determine the EC50 or IC50 value.^{[10][13]}

Parameter	Description	Typical Value for On-Target Effect
EC50 / IC50	The concentration of a drug that gives a half-maximal response.	Consistent with known PPAR α binding affinity (typically in the nM to low μ M range for fibrates).
Hill Slope	Describes the steepness of the curve.	A slope around 1.0 suggests a simple 1:1 interaction.
Maximal Effect	The plateau of the curve at high concentrations.	Should reach a clear and consistent maximum.

Step 2: Employ Negative and Orthogonal Controls

Q4: What are negative and orthogonal controls, and why are they critical for validating a chemical probe?

A: This is one of the most important steps in ruling out off-target effects. The principle of using proper controls is a cornerstone of chemical biology.^[6]

- **Negative Control:** A molecule that is structurally very similar to your active compound (**Eniclobrate**) but is biologically inactive against the intended target (PPAR α). If the negative control does not produce your phenotype, while **Eniclobrate** does, it strongly suggests the effect is mediated by the specific chemical structure of **Eniclobrate** and is not a result of non-specific chemistry or cytotoxicity.
- **Orthogonal Control:** A structurally distinct compound that hits the same target (PPAR α) through a different binding mode or chemical scaffold. If an orthogonal PPAR α agonist reproduces the same phenotype as **Eniclobrate**, it significantly strengthens the conclusion that the effect is on-target.

Recommended Controls for **Eniclobrate**:

- **Negative Control:** Finding a validated, commercially available inactive enantiomer or analog for every probe can be challenging. While a specific inactive analog for **Eniclobrate** is not widely documented, a suitable strategy is to use a structurally related fibrate that is known to

have significantly lower or no activity on PPAR α . Alternatively, if your lab has access to medicinal chemistry resources, synthesizing an analog with a key functional group removed (e.g., the carboxylic acid common to many fibrates) can serve this purpose.

- **Orthogonal Control:** Use a different class of PPAR α agonist. For example, GW7647 is a potent and selective PPAR α agonist that is structurally different from the fibrate class.

Experimental Approach:

Perform the same dose-response experiment as in Step 1, but run **Eniclobrate**, your chosen negative control, and an orthogonal control in parallel. The expected outcome for an on-target effect is shown below.

Compound	Expected Phenotypic Response	Rationale
Eniclobrate	Potent and dose-dependent effect	Active compound engages the target.
Negative Control	No effect or significantly weaker effect	The phenotype requires the specific structure for target engagement.
Orthogonal Control	Similar potent and dose-dependent effect	The phenotype is linked to the target (PPAR α), not the chemical scaffold.

Step 3: Confirm Target Engagement with CETSA

Q5: My dose-response and control experiments look good. How can I be sure **Eniclobrate** is actually binding to PPAR α inside my cells?

A: To directly confirm that **Eniclobrate** engages PPAR α in your intact cells, the Cellular Thermal Shift Assay (CETSA) is the gold standard.^{[14][15]} The principle is that when a drug binds to its target protein, it generally stabilizes the protein's structure, making it more resistant to heat-induced denaturation.^[16]

Experimental Protocol: CETSA with Western Blot Readout

- **Cell Treatment:** Treat two populations of your cells, one with vehicle (DMSO) and one with a saturating concentration of **Eniclobrate** (e.g., 10-20x the EC50) for a sufficient time to allow cell entry and binding (e.g., 1-2 hours).
- **Heating:** Aliquot the cell suspensions from each group into separate PCR tubes. Heat the aliquots across a temperature gradient (e.g., 40°C to 70°C in 3-5°C increments) for 3-5 minutes, followed by rapid cooling on ice.[\[17\]](#)
- **Cell Lysis:** Lyse the cells using a freeze-thaw method or a gentle lysis buffer to release the soluble proteins.
- **Centrifugation:** Pellet the aggregated, denatured proteins by high-speed centrifugation (e.g., 20,000 x g for 20 minutes at 4°C).
- **Western Blot:** Collect the supernatant (containing the soluble, non-denatured proteins) and analyze the amount of PPAR α remaining in solution using SDS-PAGE and Western blotting with a specific PPAR α antibody.

Interpreting the Results:

In the vehicle-treated cells, as the temperature increases, PPAR α will denature and precipitate, so the amount detected in the supernatant will decrease. In the **Eniclobrate**-treated cells, the bound drug will stabilize PPAR α , so it will remain soluble at higher temperatures. This results in a "thermal shift" of the melting curve to the right. A positive shift is direct evidence of target engagement.

Step 4: Validate with Genetic Target Knockdown

Q6: How can I definitively link the PPAR α protein to my observed phenotype?

A: The most definitive way to link a protein to a cellular event is to remove the protein and see if the event still occurs. Using small interfering RNA (siRNA) to "knock down" the expression of the PPAR α protein (PPARA gene) is a powerful validation method.[\[18\]](#)[\[19\]](#) If the phenotype you observe with **Eniclobrate** is diminished or abolished in cells lacking PPAR α , you have strong evidence that the effect is on-target.

Experimental Protocol: siRNA Knockdown Validation

- **Transfection:** Transfect your cells with either an siRNA specifically targeting PPARA mRNA or a non-targeting "scrambled" siRNA as a negative control.[20] Follow a standard transfection protocol suitable for your cell line.
- **Incubation:** Allow 48-72 hours for the siRNA to take effect and for the existing PPAR α protein to be degraded.
- **Validation of Knockdown:** Before proceeding, it is essential to validate that the knockdown was successful. Harvest a portion of the cells from the scrambled siRNA and PPARA siRNA groups and confirm a significant reduction in PPAR α protein levels via Western blot or mRNA levels via qPCR.
- **Eniclobrate Treatment:** Treat both the scrambled control cells and the PPARA-knockdown cells with **Eniclobrate** at a concentration that gives a robust response (e.g., the EC50 or EC80 from your dose-response curve). Also include vehicle-treated controls for both siRNA groups.
- **Phenotypic Assay:** After the appropriate treatment duration, measure your phenotype of interest.

Expected Outcomes:

siRNA Condition	Eniclobrate Treatment	Expected Result for On-Target Effect
Scrambled Control	Vehicle	Baseline phenotype
Scrambled Control	Eniclobrate	Robust phenotypic change
PPARA Knockdown	Vehicle	May show a baseline shift if PPAR α has a tonic role
PPARA Knockdown	Eniclobrate	Phenotypic change is significantly reduced or abolished

Step 5: Differentiate Reversible vs. Irreversible Effects with a Washout Experiment

Q7: I see a sustained effect even after removing **Eniclobrate**. What does this mean?

A: A washout experiment helps determine the reversibility of the drug's effect.[21] On-target effects, especially those involving the regulation of gene expression like with PPAR α , often lead to changes that can persist for some time even after the drug is removed. In contrast, many non-specific or weakly-binding off-target effects are often more transient and will reverse quickly upon removal of the compound.[22]

Experimental Protocol: Washout Assay

- Treatment: Treat cells with a robust concentration of **Eniclobrate** for a defined period (e.g., 2-4 hours).
- Washout: Remove the drug-containing medium. Wash the cells thoroughly 2-3 times with fresh, pre-warmed medium to remove all traces of the compound.
- Recovery: Add fresh, drug-free medium to the cells and return them to the incubator.
- Time-Course Analysis: Harvest cells and measure your phenotype at several time points post-washout (e.g., 0, 2, 6, 12, 24 hours).
- Analysis: Compare the phenotype at different time points to the phenotype of cells continuously exposed to **Eniclobrate** and to vehicle-treated cells.

Interpreting the Results:

- Sustained Effect: If the phenotype (e.g., expression of a PPAR α target gene like ACOX1) remains altered for many hours post-washout, it is consistent with a durable on-target biological response (i.e., the transcriptional machinery was activated and the resulting mRNA/proteins persist).[23]
- Rapid Reversal: If the phenotype quickly returns to baseline after washout, it may suggest a more transient, reversible off-target interaction.

Section 3: Frequently Asked Questions (FAQs)

Q8: I'm seeing increased cell proliferation at low doses of **Eniclobrate** and inhibition at high doses. Is this normal? A: This biphasic response is not uncommon for fibrates and can be an off-target effect. Some studies have reported that at low concentrations, which may be clinically relevant, certain fibrates can increase cell proliferation, while higher concentrations are inhibitory.[8] This highlights the critical importance of performing full dose-response curves and not relying on a single high concentration.

Q9: How do I measure on-target gene activation directly? A: The most direct way is to measure changes in the mRNA levels of known PPAR α target genes using quantitative PCR (qPCR). Classical PPAR α target genes include those involved in fatty acid oxidation, such as Acyl-CoA Oxidase 1 (ACOX1) and Carnitine Palmitoyltransferase 1 (CPT1).[24] Treat your cells with **Eniclobrate** and a vehicle control for a suitable time (e.g., 6-24 hours), extract RNA, and perform qPCR using validated primers for your target genes and a stable housekeeping gene for normalization. A significant upregulation of these genes in response to **Eniclobrate** is a strong indicator of on-target activity.

Q10: What if I can't find a perfect negative control for **Eniclobrate**? A: The validation of chemical probes is an area of active discussion, and perfect tools are not always available.[25] [26] If a validated inactive analog is not available, your experimental conclusions must rely more heavily on the convergence of evidence from the other validation techniques: a clean dose-response, confirmation with an orthogonal agonist, direct evidence of target engagement from CETSA, and loss of the phenotype upon genetic knockdown of PPAR α .

References

- Fenofibrate, a peroxisome proliferator-activated receptor α -agonist, blocks lipopolysaccharide-induced inflammatory pathways in mouse liver. (n.d.). National Institutes of Health. [\[Link\]](#)
- (PDF) Peroxisome Proliferator-Activated Receptor Alpha Target Genes. (n.d.). ResearchGate. [\[Link\]](#)
- [Molecular mechanism of action of the fibrates]. (2000). PubMed. [\[Link\]](#)

- Identification of Novel Peroxisome Proliferator-Activated Receptor α (PPAR α) Target Genes in Mouse Liver Using cDNA Microarray Analysis. (2018). National Institutes of Health. [\[Link\]](#)
- PPAR Alpha Activation by Clofibrate Alleviates Ischemia/Reperfusion Injury in Metabolic Syndrome Rats by Decreasing Cardiac Inflammation and Remodeling and by Regulating the Atrial Natriuretic Peptide Compensatory Response. (2023). PubMed Central. [\[Link\]](#)
- Peroxisome proliferator-activated receptor alpha. (n.d.). Wikipedia. [\[Link\]](#)
- PPAR α -independent action against metabolic syndrome development by fibrates is mediated by inhibition of STAT3 signalling. (2018). PubMed. [\[Link\]](#)
- Fibrates, glitazones, and peroxisome proliferator-activated receptors. (n.d.). National Institutes of Health. [\[Link\]](#)
- Novel Use of a Lipid-Lowering Fibrate Medication to Prevent Nicotine Reward and Relapse: Preclinical Findings. (2012). PubMed Central. [\[Link\]](#)
- siRNA knockdown validation 101: Incorporating negative controls in antibody research. (2016). F1000Research. [\[Link\]](#)
- PPAR α -independent action against metabolic syndrome development by fibrates is mediated by inhibition of STAT3 signaling. (n.d.). PubMed Central. [\[Link\]](#)
- Best Practices for Chemical Probes. (2016). Alto Predict. [\[Link\]](#)
- Screening for Target Engagement using the Cellular Thermal Shift Assay - CETSA. (2016). National Center for Biotechnology Information. [\[Link\]](#)
- Dose–Response Curves and the Determination of IC50 and EC50 Values. (2024). ACS Publications. [\[Link\]](#)
- Clofibrate PPAR α activation reduces oxidative stress and improves ultrastructure and ventricular hemodynamics in no-flow myocardial ischemia. (n.d.). PubMed. [\[Link\]](#)
- Prolonged and tunable residence time using reversible covalent kinase inhibitors. (n.d.). PubMed Central. [\[Link\]](#)

- Mitigating off-target effects in CRISPR/Cas9-mediated in vivo gene editing. (n.d.). PubMed Central. [[Link](#)]
- How to design effective siRNA for gene knockdown experiments? (2025). Patsnap Synapse. [[Link](#)]
- Validating Small Molecule Chemical Probes for Biological Discovery. (n.d.). Annual Reviews. [[Link](#)]
- Determination of Ligand-Target Interaction in vitro by Cellular Thermal Shift Assay and Isothermal Dose-response Fingerprint Assay. (n.d.). Bio-protocol. [[Link](#)]
- Drug dose-response data analysis. (2021). Towards Data Science. [[Link](#)]
- PPAR Alpha Activation by Clofibrate Alleviates Ischemia/Reperfusion Injury in Metabolic Syndrome Rats by Decreasing Cardiac Inflammation and Remodeling and by Regulating the Atrial Natriuretic Peptide Compensatory Response. (n.d.). PubMed. [[Link](#)]
- Latest Developed Strategies to Minimize the Off-Target Effects in CRISPR-Cas-Mediated Genome Editing. (n.d.). MDPI. [[Link](#)]
- A practical guide for the assay-dependent characterisation of irreversible inhibitors. (2024). National Institutes of Health. [[Link](#)]
- Cellular Thermal Shift Assay (CETSA). (2020). News-Medical.net. [[Link](#)]
- Molecular Actions of PPAR α in Lipid Metabolism and Inflammation. (n.d.). Oxford Academic. [[Link](#)]
- A multitargeted probe-based strategy to identify signaling vulnerabilities in cancers. (2020). Journal of Biological Chemistry. [[Link](#)]
- How siRNA Knockdown Antibody Validation Works. (2017). Lab Manager. [[Link](#)]
- Gene expression profiling of potential peroxisome proliferator-activated receptor (PPAR) target genes in human hepatoblastoma cell lines inducibly expressing different PPAR isoforms. (n.d.). PubMed Central. [[Link](#)]

- Top Strategies To Reduce Off-Target Effects For Safer Genome Editing. (2024). Cell and Gene. [\[Link\]](#)
- Prolonged and tunable residence time using reversible covalent kinase inhibitors. (n.d.). Nature. [\[Link\]](#)
- Meta-analysis of primary target genes of peroxisome proliferator-activated receptors. (n.d.). PubMed Central. [\[Link\]](#)
- High-Throughput Dose-Response Data Analysis. (2024). Medium. [\[Link\]](#)
- The Cellular Thermal Shift Assay: A Novel Biophysical Assay for In Situ Drug Target Engagement and Mechanistic Biomarker Studies. (2015). Annual Review of Pharmacology and Toxicology. [\[Link\]](#)
- ICH guideline Q2(R2) on validation of analytical procedures. (2022). European Medicines Agency. [\[Link\]](#)
- How can we generate siRNA to knockdown specific target in cells? (2021). ResearchGate. [\[Link\]](#)
- 50% of what? How exactly are IC50 and EC50 defined? (n.d.). GraphPad. [\[Link\]](#)
- Targeting Protein Kinases with Selective and Semi-Promiscuous Covalent Inhibitors. (2014). National Institutes of Health. [\[Link\]](#)
- Strategies to Avoid and Reduce Off-Target Effects. (n.d.). CRISPR Medicine News. [\[Link\]](#)
- Validation of Analytical Procedures Q2(R2). (2023). ICH. [\[Link\]](#)
- Full article: Application of the Cellular Thermal Shift Assay (CETSA) to validate drug target engagement in platelets. (2024). Taylor & Francis Online. [\[Link\]](#)
- How to measure and minimize off-target effects... (2021). YouTube. [\[Link\]](#)
- Chemical Probes Portal. (n.d.). Wikipedia. [\[Link\]](#)

Need Custom Synthesis?

BenchChem offers custom synthesis for rare earth carbides and specific isotopic labeling.

Email: info@benchchem.com or [Request Quote Online](#).

Sources

- 1. [Molecular mechanism of action of the fibrates] - PubMed [pubmed.ncbi.nlm.nih.gov]
- 2. Fibrates, glitazones, and peroxisome proliferator-activated receptors - PMC [pmc.ncbi.nlm.nih.gov]
- 3. academic.oup.com [academic.oup.com]
- 4. Fenofibrate, a peroxisome proliferator-activated receptor α -agonist, blocks lipopolysaccharide-induced inflammatory pathways in mouse liver - PMC [pmc.ncbi.nlm.nih.gov]
- 5. PPAR Alpha Activation by Clofibrate Alleviates Ischemia/Reperfusion Injury in Metabolic Syndrome Rats by Decreasing Cardiac Inflammation and Remodeling and by Regulating the Atrial Natriuretic Peptide Compensatory Response - PMC [pmc.ncbi.nlm.nih.gov]
- 6. Best Practices for Chemical Probes - Alto Predict [altopredict.com]
- 7. Mitigating off-target effects in CRISPR/Cas9-mediated in vivo gene editing - PMC [pmc.ncbi.nlm.nih.gov]
- 8. PPAR α -independent action against metabolic syndrome development by fibrates is mediated by inhibition of STAT3 signalling - PubMed [pubmed.ncbi.nlm.nih.gov]
- 9. PPAR α -independent action against metabolic syndrome development by fibrates is mediated by inhibition of STAT3 signaling - PMC [pmc.ncbi.nlm.nih.gov]
- 10. pubs.acs.org [pubs.acs.org]
- 11. towardsdatascience.com [towardsdatascience.com]
- 12. database.ich.org [database.ich.org]
- 13. 50% of what? How exactly are IC50 and EC50 defined? - FAQ 1356 - GraphPad [graphpad.com]
- 14. Screening for Target Engagement using the Cellular Thermal Shift Assay - CETSA - Assay Guidance Manual - NCBI Bookshelf [ncbi.nlm.nih.gov]
- 15. news-medical.net [news-medical.net]

- [16. bio-protocol.org \[bio-protocol.org\]](https://www.bio-protocol.org)
- [17. tandfonline.com \[tandfonline.com\]](https://www.tandfonline.com)
- [18. siRNA knockdown validation 101: Incorporating negative controls in antibody research - PMC \[pmc.ncbi.nlm.nih.gov\]](https://pubmed.ncbi.nlm.nih.gov/)
- [19. How siRNA Knockdown Antibody Validation Works | Lab Manager \[labmanager.com\]](https://www.labmanager.com)
- [20. Meta-analysis of primary target genes of peroxisome proliferator-activated receptors - PMC \[pmc.ncbi.nlm.nih.gov\]](https://pubmed.ncbi.nlm.nih.gov/)
- [21. Targeting Protein Kinases with Selective and Semi-Promiscuous Covalent Inhibitors - PMC \[pmc.ncbi.nlm.nih.gov\]](https://pubmed.ncbi.nlm.nih.gov/)
- [22. ccsp.hms.harvard.edu \[ccsp.hms.harvard.edu\]](https://ccsp.hms.harvard.edu)
- [23. researchgate.net \[researchgate.net\]](https://www.researchgate.net)
- [24. Peroxisome proliferator-activated receptor alpha - Wikipedia \[en.wikipedia.org\]](https://en.wikipedia.org)
- [25. annualreviews.org \[annualreviews.org\]](https://www.annualreviews.org)
- [26. Gene expression profiling of potential peroxisome proliferator-activated receptor \(PPAR\) target genes in human hepatoblastoma cell lines inducibly expressing different PPAR isoforms - PMC \[pmc.ncbi.nlm.nih.gov\]](https://pubmed.ncbi.nlm.nih.gov/)
- To cite this document: BenchChem. [Technical Support Center: Eniclobrate & Cell Culture Applications]. BenchChem, [2026]. [Online PDF]. Available at: [\[https://www.benchchem.com/product/b10781295/docs#technical-support-center-eniclobrate-cell-culture-applications\]](https://www.benchchem.com/product/b10781295/docs#technical-support-center-eniclobrate-cell-culture-applications)

Disclaimer & Data Validity:

The information provided in this document is for Research Use Only (RUO) and is strictly not intended for diagnostic or therapeutic procedures. While BenchChem strives to provide accurate protocols, we make no warranties, express or implied, regarding the fitness of this product for every specific experimental setup.

Technical Support: The protocols provided are for reference purposes. Unsure if this reagent suits your experiment?

Need Industrial/Bulk Grade? [Request Custom Synthesis Quote](#)

BenchChem

Our mission is to be the trusted global source of essential and advanced chemicals, empowering scientists and researchers to drive progress in science and industry.

Contact

Address: 3281 E Guasti Rd

Ontario, CA 91761, United States

Phone: (601) 213-4426

Email: info@benchchem.com

[Contact our Ph.D. Support Team for a compatibility check](#)