

Technical Support Center: Addressing Potential RC-3095 Resistance in Long-Term Studies

Author: BenchChem Technical Support Team. **Date:** April 2026

Compound of Interest

Compound Name: RC-3095
Cat. No.: B10781932

[Get Quote](#)

This technical support center provides researchers, scientists, and drug development professionals with guidance on anticipating, identifying, and troubleshooting potential resistance to the Gastrin-Releasing Peptide (GRP) receptor antagonist, **RC-3095**, during long-term experimental studies.

Frequently Asked Questions (FAQs)

Q1: What is the primary mechanism of action for **RC-3095**?

A1: **RC-3095** is a synthetic peptide that acts as a competitive antagonist for the Gastrin-Releasing Peptide Receptor (GRPR). By binding to GRPR, it blocks the downstream signaling pathways typically initiated by the natural ligand, GRP.^{[1][2]} This inhibition can disrupt critical cellular processes for cancer cell proliferation, survival, and differentiation.^[1]

Q2: What are the potential mechanisms of acquired resistance to **RC-3095** in long-term cell culture?

A2: While specific resistance mechanisms to **RC-3095** have not been extensively documented, based on general principles of resistance to targeted therapies, several hypotheses can be proposed:

- Upregulation of GRPR expression: Cells may increase the number of GRP receptors on their surface, requiring higher concentrations of **RC-3095** to achieve the same level of inhibition.
- Mutations in the GRPR gene: Alterations in the GRPR gene could change the receptor's structure, preventing **RC-3095** from binding effectively while potentially preserving some level of basal signaling.
- Activation of bypass signaling pathways: Cancer cells can develop resistance by activating alternative signaling pathways to compensate for the GRPR blockade.[3][4] Pathways such as the MAPK/ERK and PI3K/Akt are common culprits in resistance to targeted therapies.[1][5]
- Increased drug efflux: Cells may upregulate the expression of ATP-binding cassette (ABC) transporters, which actively pump **RC-3095** out of the cell, reducing its intracellular concentration and efficacy.[6]

Q3: How can I develop an **RC-3095** resistant cell line for my studies?

A3: Developing a resistant cell line in vitro typically involves long-term, continuous exposure of a sensitive parental cell line to gradually increasing concentrations of the drug.[7][8] This process selects for cells that have acquired resistance mechanisms. A general protocol is provided in the "Experimental Protocols" section below.

Q4: What are the first signs of developing resistance in my long-term culture?

A4: The primary indicator of developing resistance is a decrease in the efficacy of **RC-3095** over time. This can be observed as:

- A gradual increase in the IC50 value (the concentration of **RC-3095** required to inhibit 50% of cell growth).
- A resumption of cell proliferation or survival at a concentration of **RC-3095** that was previously effective.
- Changes in cellular morphology.

Troubleshooting Guide

Issue	Possible Causes	Recommended Solutions
High variability in cell viability assays between replicates.	Inconsistent cell seeding, pipetting errors, edge effects in microplates.[9]	Ensure a homogenous cell suspension before and during plating. Calibrate pipettes regularly and use proper pipetting technique. Avoid using the outer wells of the plate or fill them with sterile media to minimize evaporation. [9]
Gradual loss of RC-3095 efficacy over several passages.	Development of acquired resistance.	See "Experimental Protocols" for methods to characterize the resistant phenotype. Consider developing a resistant cell line for further investigation.
Unexpected changes in cell morphology or growth rate in treated cultures.	Cellular stress response, selection of a resistant subpopulation.	Monitor morphological changes using microscopy. Perform cell cycle analysis to investigate alterations in proliferation.
Inconsistent results in downstream signaling assays (e.g., Western blot).	Poor antibody quality, improper sample preparation, loading inaccuracies.	Validate antibodies for specificity. Ensure consistent protein extraction and quantification. Use a reliable loading control for normalization.

Experimental Protocols

Protocol 1: Development of an RC-3095 Resistant Cell Line

This protocol describes a method for generating a drug-resistant cell line through continuous exposure to escalating doses of **RC-3095**.[\[7\]](#)[\[8\]](#)

Materials:

- Parental cancer cell line sensitive to **RC-3095**
- Complete cell culture medium
- **RC-3095** stock solution
- Cell counting solution (e.g., trypan blue)
- Cell culture flasks and plates

Methodology:

- Determine the initial IC₅₀ of **RC-3095**: Perform a dose-response experiment to determine the concentration of **RC-3095** that inhibits 50% of the parental cell line's growth.
- Initial continuous exposure: Culture the parental cells in a medium containing **RC-3095** at a concentration equal to the IC₅₀.
- Monitor cell viability: Continuously monitor the cells for growth and viability. Initially, a significant portion of the cells may die.
- Dose escalation: Once the cell population recovers and resumes stable growth, increase the concentration of **RC-3095** in the culture medium by 1.5- to 2-fold.[8]
- Repeat dose escalation: Repeat steps 3 and 4, gradually increasing the **RC-3095** concentration. The development of significant resistance can take several months.[10]
- Characterize the resistant phenotype: Once the cells are able to proliferate in a significantly higher concentration of **RC-3095** (e.g., 5-10 fold higher than the initial IC₅₀), perform experiments to confirm and characterize the resistance. This includes re-evaluating the IC₅₀ and assessing potential resistance mechanisms.

Protocol 2: Assessing Changes in GRPR Expression by Flow Cytometry

Materials:

- Parental and **RC-3095** resistant cell lines
- Phosphate-buffered saline (PBS)
- Fixation buffer (e.g., 4% paraformaldehyde in PBS)
- Permeabilization buffer (e.g., 0.1% Triton X-100 in PBS)
- Blocking buffer (e.g., 5% BSA in PBS)
- Primary antibody against GRPR
- Fluorescently labeled secondary antibody
- Flow cytometer

Methodology:

- Cell preparation: Harvest and wash both parental and resistant cells with cold PBS.
- Fixation and permeabilization: Fix and permeabilize the cells to allow antibody access to intracellular epitopes if necessary.
- Blocking: Incubate the cells in blocking buffer to reduce non-specific antibody binding.
- Primary antibody incubation: Incubate the cells with the primary antibody against GRPR.
- Secondary antibody incubation: Wash the cells and incubate with the fluorescently labeled secondary antibody.
- Flow cytometry analysis: Analyze the cells on a flow cytometer to quantify the mean fluorescence intensity, which corresponds to the level of GRPR expression.

Protocol 3: Evaluation of Alternative Signaling Pathway Activation by Western Blot

Materials:

- Parental and **RC-3095** resistant cell lines
- **RC-3095**
- Lysis buffer with protease and phosphatase inhibitors
- Protein quantification assay (e.g., BCA assay)
- SDS-PAGE gels and running buffer
- Transfer buffer and nitrocellulose or PVDF membranes
- Blocking buffer (e.g., 5% non-fat milk or BSA in TBST)
- Primary antibodies (e.g., anti-phospho-ERK, anti-ERK, anti-phospho-Akt, anti-Akt, and a loading control like GAPDH or β -actin)
- HRP-conjugated secondary antibodies
- Chemiluminescent substrate

Methodology:

- Cell treatment and lysis: Treat parental and resistant cells with and without **RC-3095** for a specified time, then lyse the cells.
- Protein quantification: Determine the protein concentration of each lysate.
- SDS-PAGE and transfer: Separate the proteins by SDS-PAGE and transfer them to a membrane.
- Blocking and antibody incubation: Block the membrane and incubate with primary antibodies overnight, followed by incubation with HRP-conjugated secondary antibodies.
- Detection: Visualize the protein bands using a chemiluminescent substrate and an imaging system.

- Analysis: Quantify the band intensities and normalize to the loading control to compare the activation (phosphorylation) of signaling proteins between parental and resistant cells.

Data Presentation

Table 1: Hypothetical IC50 Values for **RC-3095** in Parental and Resistant Cell Lines

Cell Line	IC50 (nM)	Fold Resistance
Parental	10	1
RC-3095 Resistant	150	15

Table 2: Hypothetical Relative GRPR Expression Levels

Cell Line	Mean Fluorescence Intensity (Arbitrary Units)
Parental	100
RC-3095 Resistant	250

Table 3: Hypothetical Densitometry Analysis of Key Signaling Proteins

Cell Line	Treatment	p-ERK / Total ERK Ratio	p-Akt / Total Akt Ratio
Parental	Vehicle	1.0	1.0
Parental	RC-3095 (10 nM)	0.2	0.3
Resistant	Vehicle	1.5	1.8
Resistant	RC-3095 (150 nM)	1.2	1.6

Visualizations

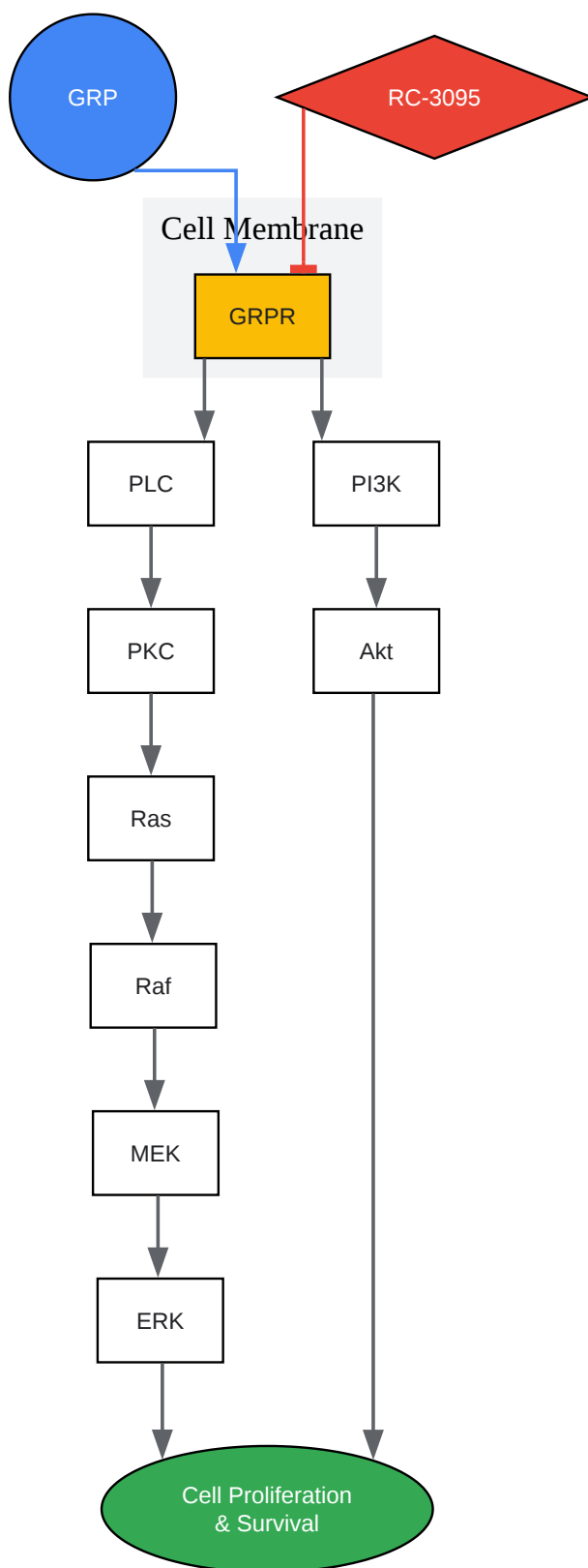

[Click to download full resolution via product page](#)

Caption: GRP/GRPR signaling and points of potential resistance.

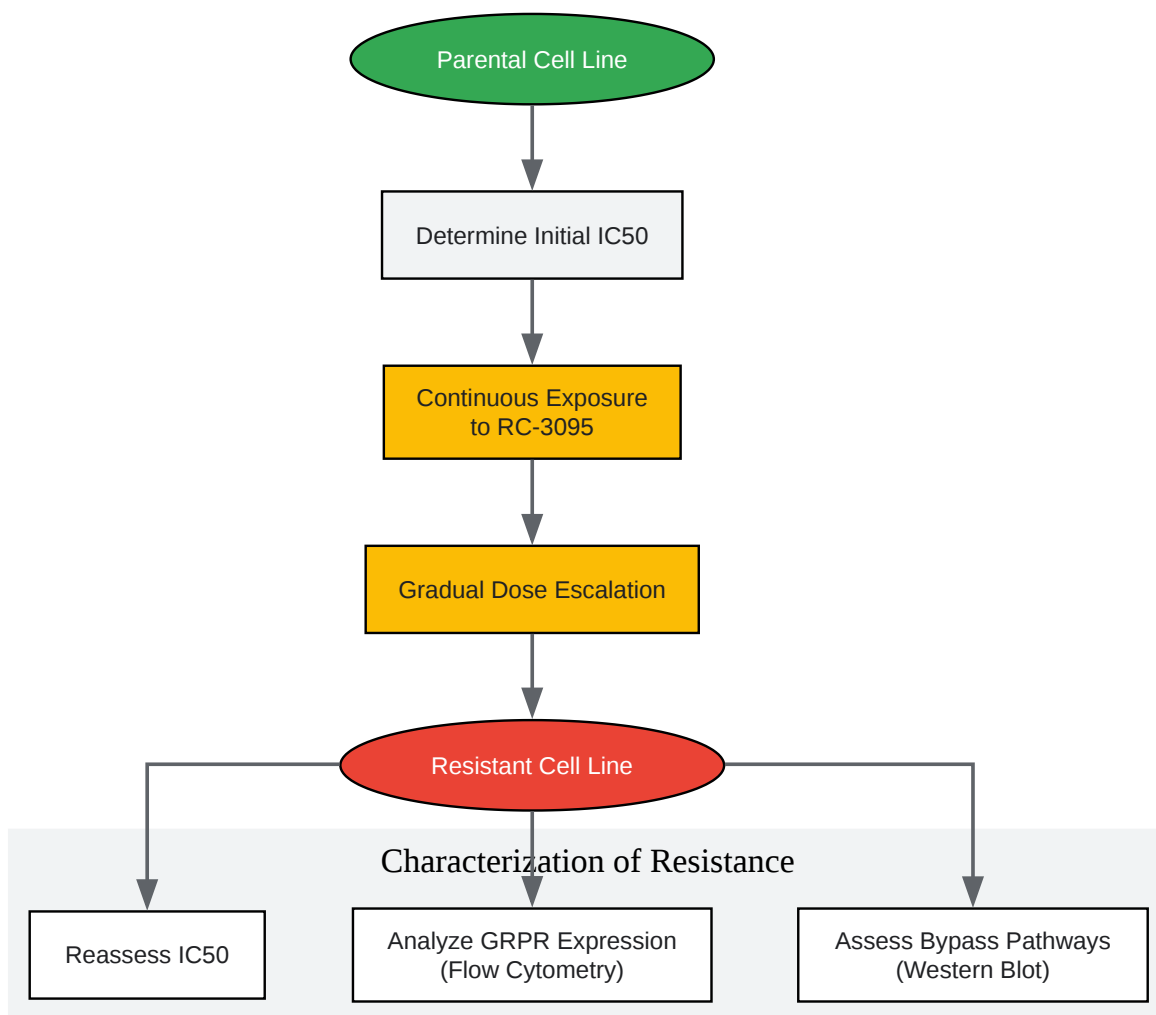

[Click to download full resolution via product page](#)

Caption: Workflow for developing and characterizing **RC-3095** resistance.

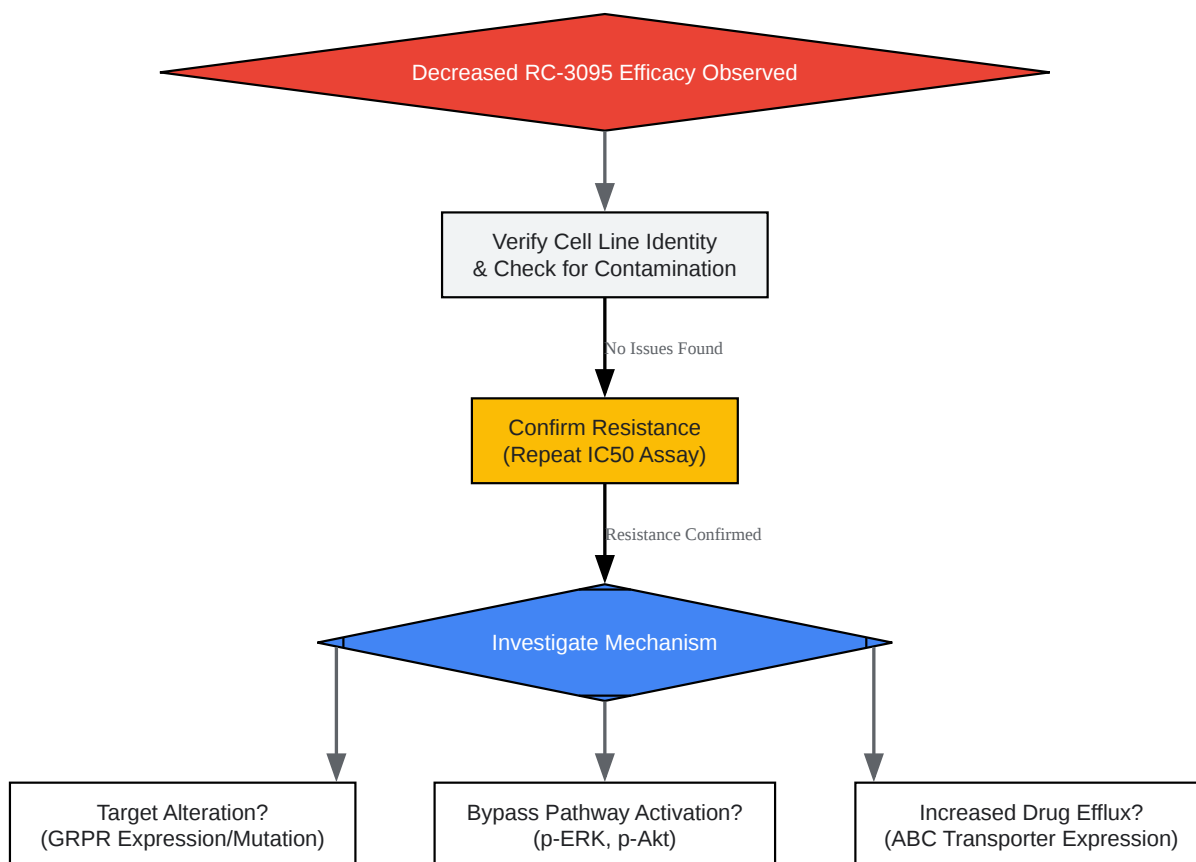

[Click to download full resolution via product page](#)

Caption: Logical workflow for troubleshooting **RC-3095** resistance.

Need Custom Synthesis?

BenchChem offers custom synthesis for rare earth carbides and specific isotopic labeling.

Email: info@benchchem.com or [Request Quote Online](#).

References

- [1. What are GRPR antagonists and how do they work? \[synapse.patsnap.com\]](#)
- [2. What are GRPR modulators and how do they work? \[synapse.patsnap.com\]](#)

- [3. Understanding and targeting resistance mechanisms in cancer - PMC \[pmc.ncbi.nlm.nih.gov\]](#)
- [4. Mechanisms of Resistance to KRAS Inhibitors: Cancer Cells' Strategic Use of Normal Cellular Mechanisms to Adapt - PubMed \[pubmed.ncbi.nlm.nih.gov\]](#)
- [5. Mechanisms of resistance to anti-epidermal growth factor receptor inhibitors in metastatic colorectal cancer - PubMed \[pubmed.ncbi.nlm.nih.gov\]](#)
- [6. Overcoming drug resistance by regulating nuclear receptors - PMC \[pmc.ncbi.nlm.nih.gov\]](#)
- [7. blog.crownbio.com \[blog.crownbio.com\]](#)
- [8. Development of Drug-resistant Cell Lines for Experimental Procedures - PMC \[pmc.ncbi.nlm.nih.gov\]](#)
- [9. benchchem.com \[benchchem.com\]](#)
- [10. researchgate.net \[researchgate.net\]](#)
- To cite this document: BenchChem. [Technical Support Center: Addressing Potential RC-3095 Resistance in Long-Term Studies]. BenchChem, [2026]. [Online PDF]. Available at: [\[https://www.benchchem.com/product/b10781932/docs#technical-support-center-addressing-potential-rc-3095-resistance-in-long-term-studies\]](https://www.benchchem.com/product/b10781932/docs#technical-support-center-addressing-potential-rc-3095-resistance-in-long-term-studies)

Disclaimer & Data Validity:

The information provided in this document is for Research Use Only (RUO) and is strictly not intended for diagnostic or therapeutic procedures. While BenchChem strives to provide accurate protocols, we make no warranties, express or implied, regarding the fitness of this product for every specific experimental setup.

Technical Support: The protocols provided are for reference purposes. Unsure if this reagent suits your experiment?

Need Industrial/Bulk Grade? [Request Custom Synthesis Quote](#)

BenchChem

Our mission is to be the trusted global source of essential and advanced chemicals, empowering scientists and researchers to drive progress in science and industry.

Contact

Address: 3281 E Guasti Rd

Ontario, CA 91761, United States

Phone: (601) 213-4426

Email: info@benchchem.com

[Contact our Ph.D. Support Team for a compatibility check](#)