

KBP-7018 in Fibrosis Models: A Comparative Analysis

Author: BenchChem Technical Support Team. **Date:** April 2026

Compound of Interest

Compound Name: *KBP-7018*
Cat. No.: *B10780405*

[Get Quote](#)

For Researchers, Scientists, and Drug Development Professionals

This guide provides a comparative overview of the preclinical validation of **KBP-7018**, a novel tyrosine kinase inhibitor, in the context of established and emerging therapies for fibrosis. Due to the limited publicly available in vivo efficacy data for **KBP-7018**, this guide focuses on its mechanism of action, in vitro performance, and a comparison with the approved anti-fibrotic agents, nintedanib and pirfenidone, based on available preclinical data in widely used fibrosis models.

Executive Summary

KBP-7018 is a potent inhibitor of several tyrosine kinases implicated in fibrogenesis, including platelet-derived growth factor receptors (PDGFR α/β), c-Kit, and RET.[1][2][3] While preclinical studies in a bleomycin-induced pulmonary fibrosis model have suggested its potential efficacy, quantitative in vivo data remains unpublished.[4] In contrast, extensive preclinical and clinical data are available for the approved drugs nintedanib and pirfenidone, demonstrating their ability to attenuate fibrosis in various animal models. This guide synthesizes the available information to aid researchers in evaluating the potential of **KBP-7018** and understanding its standing relative to current therapeutic options.

Mechanism of Action and Signaling Pathways

KBP-7018 exerts its potential anti-fibrotic effects by targeting key signaling pathways involved in fibroblast activation, proliferation, and extracellular matrix (ECM) deposition.

Targeted Signaling Pathways of **KBP-7018**:

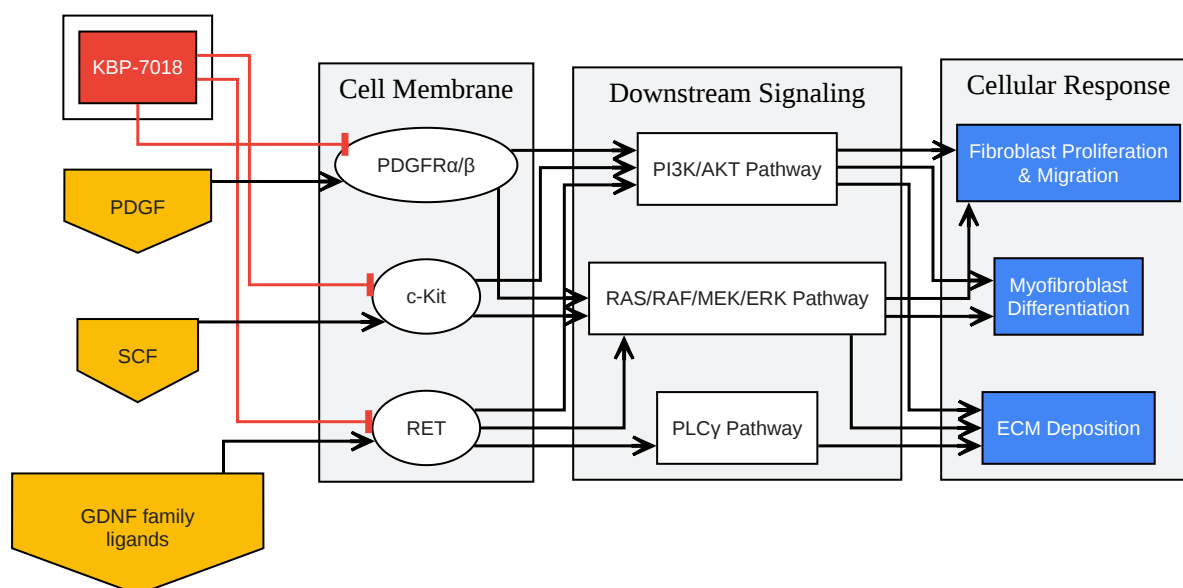

[Click to download full resolution via product page](#)

Caption: KBP-7018 inhibits key tyrosine kinases involved in fibrosis.

Comparative In Vitro Data

While comprehensive in vivo comparative data is lacking, in vitro studies provide some insights into the properties of **KBP-7018** relative to nintedanib.

Parameter	KBP-7018	Nintedanib	Reference
Apparent Permeability (P _{app}) A to B (10 ⁻⁶ cm/s)	1.8 ± 0.1	1.4 ± 0.1	[5]
Apparent Permeability (P _{app}) B to A (10 ⁻⁶ cm/s)	2.9 ± 0.2	2.5 ± 0.2	
Efflux Ratio (B to A / A to B)	1.6	1.8	

Preclinical In Vivo Models of Fibrosis: A Comparison

The bleomycin-induced pulmonary fibrosis model is a standard for evaluating potential anti-fibrotic therapies. Below is a summary of the model and the reported, albeit qualitative, findings for **KBP-7018**, alongside quantitative data for nintedanib and pirfenidone.

Experimental Workflow: Bleomycin-Induced Pulmonary Fibrosis

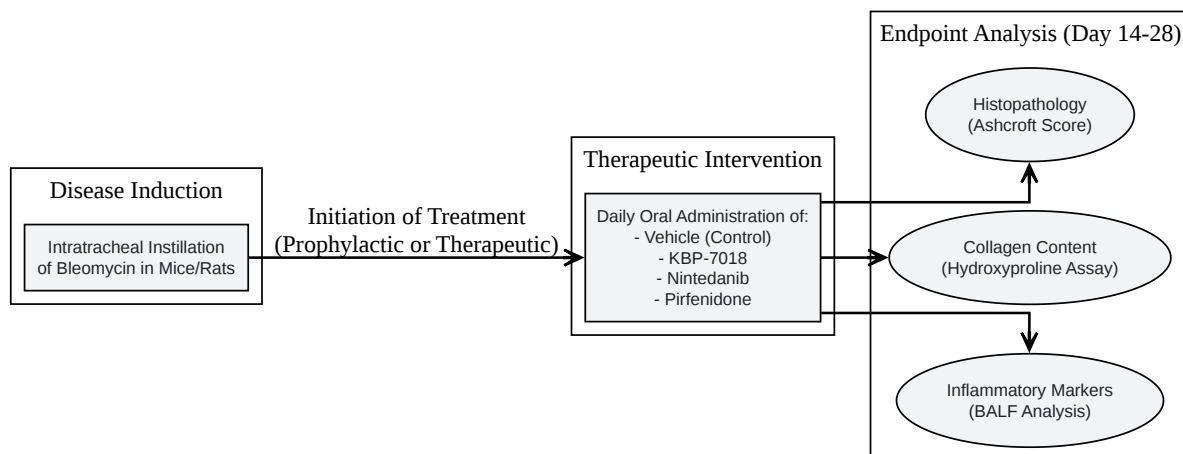

[Click to download full resolution via product page](#)

Need Custom Synthesis?

BenchChem offers custom synthesis for rare earth carbides and specific isotopic labeling.

Email: info@benchchem.com or [Request Quote Online](#).

References

- [1. medkoo.com \[medkoo.com\]](https://www.medkoo.com)
- [2. KBP-7018|KBP 7018;KBP7018 \[dcchemicals.com\]](https://www.dcchemicals.com)
- [3. KBP-7018 HCl - Immunomart \[immunomart.com\]](https://www.immunomart.com)
- [4. Characterization of preclinical in vitro and in vivo pharmacokinetics properties for KBP-7018, a new tyrosine kinase inhibitor candidate for treatment of idiopathic pulmonary fibrosis - PubMed \[pubmed.ncbi.nlm.nih.gov\]](https://pubmed.ncbi.nlm.nih.gov)
- [5. researchgate.net \[researchgate.net\]](https://www.researchgate.net)
- To cite this document: BenchChem. [KBP-7018 in Fibrosis Models: A Comparative Analysis]. BenchChem, [2026]. [Online PDF]. Available at:

[\[https://www.benchchem.com/product/b10780405/docs#kbp-7018-in-fibrosis-models-a-comparative-analysis\]](https://www.benchchem.com/product/b10780405/docs#kbp-7018-in-fibrosis-models-a-comparative-analysis)

Disclaimer & Data Validity:

The information provided in this document is for Research Use Only (RUO) and is strictly not intended for diagnostic or therapeutic procedures. While BenchChem strives to provide accurate protocols, we make no warranties, express or implied, regarding the fitness of this product for every specific experimental setup.

Technical Support: The protocols provided are for reference purposes. Unsure if this reagent suits your experiment?

Need Industrial/Bulk Grade? [Request Custom Synthesis Quote](#)

BenchChem

Our mission is to be the trusted global source of essential and advanced chemicals, empowering scientists and researchers to drive progress in science and industry.

Contact

Address: 3281 E Guasti Rd
Ontario, CA 91761, United States
Phone: (601) 213-4426
Email: info@benchchem.com

[Contact our Ph.D. Support Team for a compatibility check](#)