

A Comprehensive Technical Guide on the Biological Activities of 20(R)-Ginsenoside RG3

Author: BenchChem Technical Support Team. **Date:** April 2026

Compound of Interest

Compound Name: 20(R)Ginsenoside RG3

Cat. No.: B10780501

[Get Quote](#)

For Researchers, Scientists, and Drug Development Professionals

Introduction

Ginsenoside RG3, a tetracyclic triterpenoid saponin isolated from *Panax ginseng*, has garnered significant attention in the scientific community for its diverse pharmacological activities.^{[1][2]} It exists as two stereoisomers, 20(S) and 20(R), which exhibit distinct biological effects.^{[1][3]} This technical guide focuses on the 20(R)-epimer of Ginsenoside RG3, providing an in-depth overview of its biological activities, underlying molecular mechanisms, and relevant experimental methodologies. The information presented herein is intended to serve as a valuable resource for researchers and professionals involved in the discovery and development of novel therapeutics.

Core Biological Activities of 20(R)-Ginsenoside RG3

20(R)-Ginsenoside RG3 has demonstrated a wide spectrum of biological effects, primarily centered around its anticancer, anti-inflammatory, neuroprotective, and anti-angiogenic properties.

Anticancer Activity

20(R)-Ginsenoside RG3 exerts its anticancer effects through multiple mechanisms, including the inhibition of cancer cell proliferation, induction of apoptosis, and suppression of metastasis. [1][4]

Key Mechanisms:

- **Inhibition of Cell Proliferation:** 20(R)-GS-Rg3 has been shown to effectively inhibit the proliferation of tumor cells.[1] One mechanism involves the upregulation of Rho GTPase activating protein 9, which is involved in cell proliferation and metastasis.[1]
- **Induction of Apoptosis:** In colorectal cancer, Ginsenoside RG3 has been found to exert antitumor effects by activating the PTEN-induced kinase 1-Parkin signaling pathway, which promotes mitochondrial autophagy.[1]
- **Modulation of Immune Response:** 20(R)-GS-Rg3 can enhance cellular immunity by promoting the activity of natural killer (NK) cells through the activation of the MAPK/ERK pathway.[1][5] This suggests its potential as an activator of NK cell cytotoxicity in cancer therapy.[5] It also stimulates the proliferation of lymphocytes and increases the levels of Th1-type cytokines like IL-2 and IFN- γ . [1]

Quantitative Data on Anticancer Effects:

Cell Line	Assay	Parameter	Value	Reference
Human Umbilical Vein Endothelial Cells (HUVEC)	Proliferation Assay (Trypan Blue Exclusion)	IC50	10 nM	[6]
Lewis Lung Carcinoma (LLC)	Cell Viability Assay	Effective Concentration	200 ng/ml	[7]

Anti-Angiogenic Activity

Angiogenesis, the formation of new blood vessels, is a critical process in tumor growth and metastasis. 20(R)-Ginsenoside RG3 has been shown to be a potent inhibitor of angiogenesis. [3][6]

Key Mechanisms:

- Inhibition of Endothelial Cell Function: Rg3 inhibits the proliferation, tube formation, and migration of human umbilical vein endothelial cells (HUVEC).[6]
- Downregulation of Pro-Angiogenic Factors: It decreases the expression of key angiogenic factors such as vascular endothelial growth factor (VEGF), basic fibroblast growth factor (b-FGF), and matrix metalloproteinases (MMP-2 and MMP-9).[3]
- Modulation of Signaling Pathways: 20(R)-Ginsenoside RG3 can affect the AKT signaling pathway and has an allosteric modulatory effect on vascular endothelial growth factor receptor 2 (VEGFR2).[8] It also decreases the activation of various signaling pathways that lead to the activation of eNOS, including the VEGF-induced Akt/eNOS pathway.[3]

Experimental Workflow for Angiogenesis Assays:

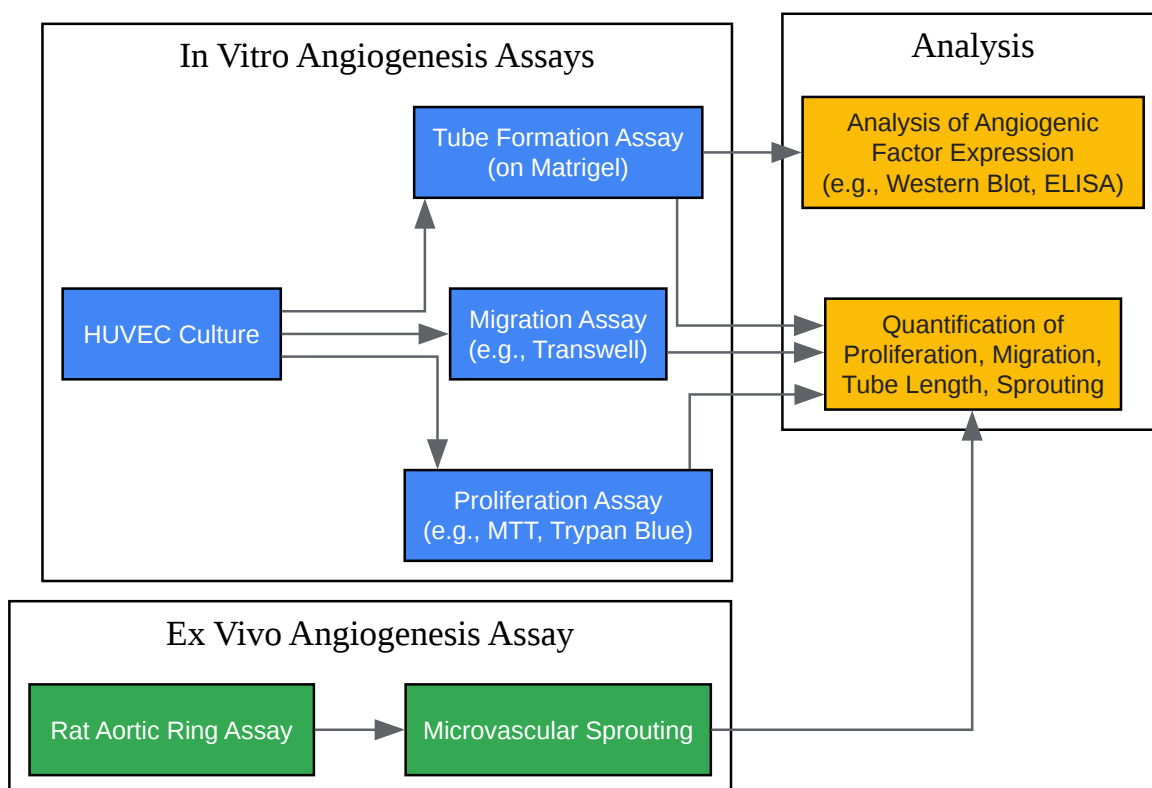

[Click to download full resolution via product page](#)

Caption: Workflow for assessing the anti-angiogenic effects of 20(R)-Ginsenoside RG3.

Neuroprotective Activity

20(R)-Ginsenoside RG3 has shown significant promise in protecting neuronal cells from various insults, making it a potential therapeutic agent for neurodegenerative diseases and ischemic stroke.[\[9\]](#)[\[10\]](#)[\[11\]](#)

Key Mechanisms:

- **Attenuation of Neuronal Apoptosis:** The neuroprotective effect of 20(R)-Rg3 is associated with the attenuation of neuronal apoptosis by downregulating the expression of calpain I and caspase-3 mRNA.[\[10\]](#)
- **Suppression of Autophagy:** In models of focal cerebral ischemia-reperfusion injury, 20(R)-ginsenoside Rg3 protects neurons by suppressing autophagy.[\[9\]](#)
- **Modulation of Signaling Pathways:** This anti-autophagic effect is mediated through the upregulation of the PI3K/Akt/mTOR signaling pathway.[\[9\]](#) In a rat model of cognitive impairment, ginsenoside Rg3 improved learning and memory by decreasing the expression of pro-inflammatory mediators like TNF- α , IL-1 β , and COX-2 in the hippocampus.[\[12\]](#)

Signaling Pathway of Neuroprotection:

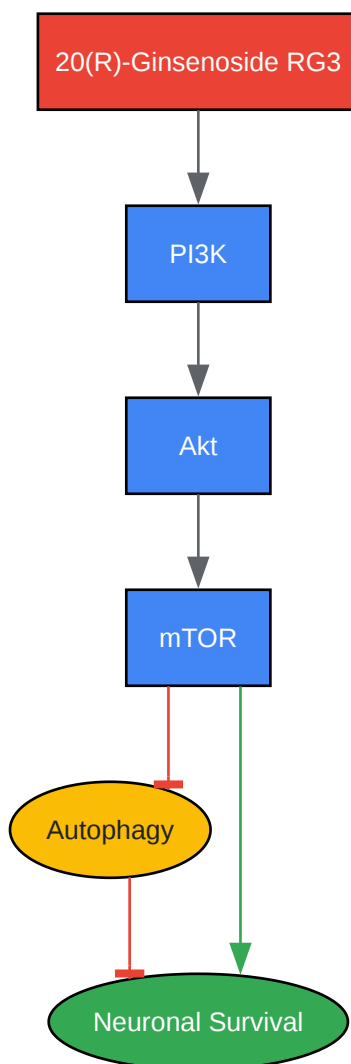

[Click to download full resolution via product page](#)

Caption: 20(R)-Ginsenoside RG3-mediated neuroprotection via the PI3K/Akt/mTOR pathway.

Anti-inflammatory Activity

20(R)-Ginsenoside RG3 exhibits potent anti-inflammatory effects by modulating the production of inflammatory mediators and regulating key inflammatory signaling pathways.[13][14]

Key Mechanisms:

- Inhibition of Pro-inflammatory Mediators: Ginsenoside Rg3 suppresses the production of nitric oxide (NO), reactive oxygen species (ROS), and prostaglandin E2 (PGE2) in activated

macrophages.[13] It also reduces the expression of cyclooxygenase-2 (COX-2) and inducible nitric oxide synthase (iNOS).[14]

- **Reduction of Pro-inflammatory Cytokines:** It decreases the production of pro-inflammatory cytokines such as tumor necrosis factor-alpha (TNF- α), interleukin-1beta (IL-1 β), and interleukin-6 (IL-6).[13][14]
- **Modulation of NF- κ B Pathway:** The anti-inflammatory effects of Rg3 are mediated, at least in part, through the regulation of the NF- κ B signaling pathway.[14]
- **Promotion of Inflammation Resolution:** Ginsenoside Rg3 can induce the M2 polarization of macrophages, which is associated with the resolution of inflammation.[15]

Quantitative Data on Anti-inflammatory Effects:

Cell Line/Model	Treatment	Measured Parameter	Effect	Reference
RAW264.7 Macrophages	LPS	NO, ROS, PGE2 Production	Suppressed	[13]
A549 Cells	-	NF- κ B Activity	Regulated	[14]
Human Asthmatic Lung Tissue	-	IL-4, TNF- α , Eotaxin Secretion	Decreased	[14]

Experimental Protocols

This section provides an overview of common experimental methodologies used to evaluate the biological activities of 20(R)-Ginsenoside RG3.

Cell Viability and Proliferation Assays

- **MTT Assay:** This colorimetric assay measures the metabolic activity of cells, which is an indicator of cell viability. Cells are treated with 20(R)-Ginsenoside RG3 for a specified period, followed by incubation with MTT (3-(4,5-dimethylthiazol-2-yl)-2,5-diphenyltetrazolium

bromide). The resulting formazan crystals are dissolved, and the absorbance is measured to determine cell viability.

- **Trypan Blue Exclusion Assay:** This assay distinguishes between viable and non-viable cells. Cells are stained with trypan blue, which is excluded by viable cells but taken up by non-viable cells. The number of viable and non-viable cells is then counted using a hemocytometer.

Apoptosis Assays

- **Annexin V/Propidium Iodide (PI) Staining:** This flow cytometry-based assay is used to detect apoptosis. Annexin V binds to phosphatidylserine, which is translocated to the outer leaflet of the plasma membrane during early apoptosis. PI is a fluorescent dye that stains the nucleus of late apoptotic and necrotic cells.
- **Western Blot Analysis of Apoptosis-Related Proteins:** The expression levels of key apoptosis-related proteins, such as caspases (e.g., caspase-3), Bax, and Bcl-2, can be determined by Western blotting to elucidate the apoptotic pathway involved.

Angiogenesis Assays

- **Tube Formation Assay:** Endothelial cells (e.g., HUVECs) are seeded on a layer of Matrigel, a basement membrane extract. In the presence of angiogenic stimuli, the cells will form tube-like structures. The anti-angiogenic potential of 20(R)-Ginsenoside RG3 can be assessed by its ability to inhibit this tube formation.
- **Transwell Migration Assay:** This assay measures the ability of endothelial cells to migrate through a porous membrane towards a chemoattractant. The inhibitory effect of 20(R)-Ginsenoside RG3 on cell migration is quantified by counting the number of cells that have migrated to the lower chamber.

Western Blot Analysis for Signaling Pathways

To investigate the effect of 20(R)-Ginsenoside RG3 on specific signaling pathways (e.g., PI3K/Akt, MAPK/ERK, NF- κ B), the phosphorylation status and total protein levels of key signaling molecules are determined by Western blotting using specific antibodies.

General Western Blot Workflow:



[Click to download full resolution via product page](#)

Caption: A generalized workflow for Western blot analysis.

Conclusion

20(R)-Ginsenoside RG3 is a promising natural compound with a wide range of biological activities, including significant anticancer, anti-inflammatory, neuroprotective, and anti-angiogenic effects. Its multifaceted mechanisms of action, involving the modulation of various signaling pathways, make it a compelling candidate for further preclinical and clinical investigation. This technical guide provides a comprehensive overview of the current understanding of 20(R)-Ginsenoside RG3, offering valuable insights for researchers and professionals in the field of drug discovery and development. Further research is warranted to fully elucidate its therapeutic potential and to translate these findings into novel clinical applications.

Need Custom Synthesis?

BenchChem offers custom synthesis for rare earth carbides and specific isotopic labeling.

Email: info@benchchem.com or [Request Quote Online](#).

References

- [1. spandidos-publications.com \[spandidos-publications.com\]](https://spandidos-publications.com)
- [2. Unveiling the experimental proof of the anticancer potential of ginsenoside Rg3 \(Review\) - PMC \[pmc.ncbi.nlm.nih.gov\]](https://pubmed.ncbi.nlm.nih.gov/31111111/)
- [3. Anti-Angiogenic Properties of Ginsenoside Rg3 \[mdpi.com\]](https://www.mdpi.com/1422-0067/23/12/21111)
- [4. spandidos-publications.com \[spandidos-publications.com\]](https://spandidos-publications.com)
- [5. Ginsenoside 20\(R\)-Rg3 enhances natural killer cell activity by increasing activating receptor expression through the MAPK/ERK signaling pathway - PubMed \[pubmed.ncbi.nlm.nih.gov\]](https://pubmed.ncbi.nlm.nih.gov/31111111/)

- [6. 218.62.10.209:8080 \[218.62.10.209:8080\]](#)
- [7. Pivotal Roles of Ginsenoside Rg3 in Tumor Apoptosis Through Regulation of Reactive Oxygen Species | Anticancer Research \[ar.iiarjournals.org\]](#)
- [8. Anti-Angiogenic Properties of Ginsenoside Rg3 Epimers: In Vitro Assessment of Single and Combination Treatments - PMC \[pmc.ncbi.nlm.nih.gov\]](#)
- [9. 20\(R\)-ginsenoside Rg3 protects against focal cerebral ischemia–reperfusion injury by suppressing autophagy via PI3K/Akt/mTOR signaling pathway - PubMed \[pubmed.ncbi.nlm.nih.gov\]](#)
- [10. Ginsenosides: A Potential Neuroprotective Agent - PMC \[pmc.ncbi.nlm.nih.gov\]](#)
- [11. researchgate.net \[researchgate.net\]](#)
- [12. alzdiscovery.org \[alzdiscovery.org\]](#)
- [13. Pro-Resolving Effect of Ginsenosides as an Anti-Inflammatory Mechanism of Panax ginseng - PMC \[pmc.ncbi.nlm.nih.gov\]](#)
- [14. Anti-Inflammatory Effects of Ginsenoside Rg3 via NF-κB Pathway in A549 Cells and Human Asthmatic Lung Tissue - PMC \[pmc.ncbi.nlm.nih.gov\]](#)
- [15. koreascience.kr \[koreascience.kr\]](#)
- [To cite this document: BenchChem. \[A Comprehensive Technical Guide on the Biological Activities of 20\(R\)-Ginsenoside RG3\]. BenchChem, \[2026\]. \[Online PDF\]. Available at: \[https://www.benchchem.com/product/b10780501/docs#a-comprehensive-technical-guide-on-the-biological-activities-of-20-r-ginsenoside-rg3\]](#)

Disclaimer & Data Validity:

The information provided in this document is for Research Use Only (RUO) and is strictly not intended for diagnostic or therapeutic procedures. While BenchChem strives to provide accurate protocols, we make no warranties, express or implied, regarding the fitness of this product for every specific experimental setup.

Technical Support: The protocols provided are for reference purposes. Unsure if this reagent suits your experiment?

Need Industrial/Bulk Grade? [Request Custom Synthesis Quote](#)

BenchChem

Our mission is to be the trusted global source of essential and advanced chemicals, empowering scientists and researchers to drive progress in science and industry.

Contact

Address: 3281 E Guasti Rd

Ontario, CA 91761, United States

Phone: (601) 213-4426

Email: info@benchchem.com

[Contact our Ph.D. Support Team for a compatibility check](#)