

The Discovery and Characterization of Quinidine N-oxide: A Technical Guide

Author: BenchChem Technical Support Team. **Date:** April 2026

Compound of Interest

Compound Name: Quinidine N-oxide

Cat. No.: B10779014

[Get Quote](#)

For Researchers, Scientists, and Drug Development Professionals

Introduction

Quinidine, a class IA antiarrhythmic agent, has been a cornerstone in the management of cardiac arrhythmias for decades. Its clinical efficacy is intrinsically linked to its metabolism, which primarily occurs in the liver, leading to the formation of several metabolites. Among these, **Quinidine N-oxide** has been identified as a significant human metabolite. This technical guide provides an in-depth overview of the discovery, characterization, and quantification of **Quinidine N-oxide**, tailored for professionals in the fields of pharmacology, drug metabolism, and analytical chemistry.

The Discovery of Quinidine N-oxide as a Human Metabolite

The first definitive identification of **Quinidine N-oxide** as a human metabolite was reported in 1982 by Guentert, Daly, and Riegelman.[1] Prior to this, while other metabolites like 3-hydroxyquinidine and 2'-quinidinone were known, a third, previously unidentified metabolic product was detected in the plasma of patients undergoing quinidine therapy.[1] Through a

combination of spectroscopic techniques and chemical synthesis, the structure of this new metabolite was unequivocally confirmed as **Quinidine N-oxide**.^[1]

Metabolic Pathway of Quinidine to Quinidine N-oxide

The formation of **Quinidine N-oxide** is a phase I metabolic reaction, specifically an N-oxidation. This biotransformation is catalyzed by the cytochrome P450 (CYP) superfamily of enzymes in the liver. Research has indicated that several CYP isoforms are involved in the metabolism of quinidine, with CYP3A4 being the most active enzyme in the formation of **Quinidine N-oxide**.^[2] Other isoforms, such as CYP2C9 and CYP2E1, also contribute to the overall metabolism of quinidine.^[2]

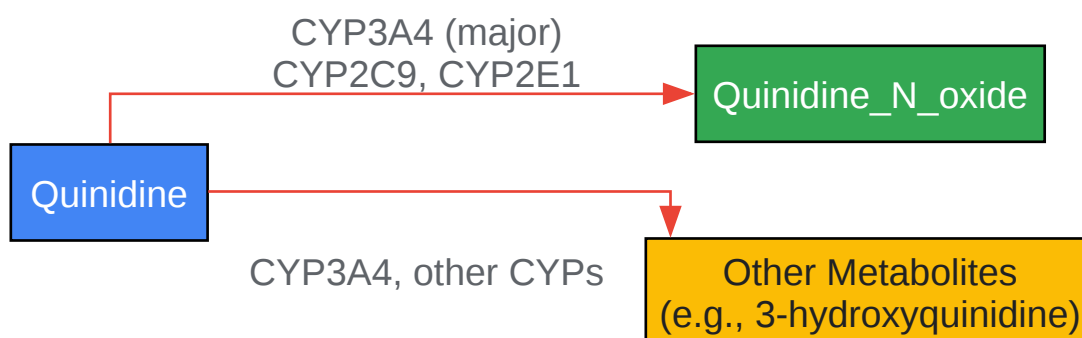

[Click to download full resolution via product page](#)

*Metabolic pathway of quinidine to **Quinidine N-oxide**.*

Quantitative Analysis of Quinidine N-oxide

The concentration of **Quinidine N-oxide** has been quantified in human plasma and urine following quinidine administration. The tables below summarize key pharmacokinetic parameters.

Table 1: Pharmacokinetic Parameters of **Quinidine N-oxide** in Healthy Subjects^[3]

Parameter	Mean Value (\pm SD)
Elimination Half-Life ($t_{1/2}$)	2.5 (\pm 0.28) hours
Renal Clearance	1.3 (\pm 0.3) L/hr
Percentage of Dose Excreted Unchanged in Urine (12h)	13.9% (\pm 3.7%)
Free Fraction in Serum	3.3% (\pm 0.83%)

Table 2: Plasma Concentrations of Quinidine and its Metabolites

Compound	Concentration after IV Infusion (mg/L, Mean \pm SD)	Trough Levels after Oral Dosing (mg/L, Mean \pm SD)
Quinidine	2.9 (\pm 0.3)	2.89 (\pm 0.50)
3-hydroxyquinidine	0.32 (\pm 0.06)	0.83 (\pm 0.36)
Quinidine N-oxide	0.28 (\pm 0.03)	0.40 (\pm 0.13)
Quinidine 10,11-dihydrodiol	0.13 (\pm 0.04)	0.38 (\pm 0.08)

Experimental Protocols

Isolation and Characterization of Quinidine N-oxide

The initial identification of **Quinidine N-oxide** involved a multi-step process combining isolation from patient plasma with chemical synthesis for confirmation.^[1]

- Isolation from Plasma: Plasma samples from patients on quinidine therapy were subjected to extraction and chromatographic procedures to isolate the unknown metabolite.
- Chemical Synthesis: **Quinidine N-oxide** was synthesized in the laboratory for comparative analysis.
- Spectroscopic Analysis: The isolated and synthetic compounds were analyzed using a suite of spectroscopic techniques:

- Mass Spectrometry (MS): Provided information on the molecular weight and fragmentation pattern, suggesting the addition of an oxygen atom to the quinidine molecule.[1]
- Nuclear Magnetic Resonance (NMR) Spectroscopy (^1H -NMR and ^{13}C -NMR): Elucidated the chemical environment of the protons and carbons, confirming the position of the N-oxide group.[1]
- Infrared (IR) and Ultraviolet (UV) Spectroscopy: Provided further structural information consistent with the N-oxide structure.[1]
- X-ray Diffraction Analysis: The final confirmation of the structure of the synthesized **Quinidine N-oxide** was achieved through X-ray crystallography.[1]

Quantification by High-Performance Liquid Chromatography (HPLC)

A common method for the quantitative analysis of **Quinidine N-oxide** in biological fluids is reverse-phase high-performance liquid chromatography (HPLC) with fluorescence detection.

Sample Preparation:

- Plasma/Serum/Urine Collection: Collect biological fluid samples from subjects.
- Protein Precipitation/Liquid-Liquid Extraction: To a measured volume of the biological sample, add a protein precipitating agent (e.g., acetonitrile) or perform a liquid-liquid extraction (e.g., with a suitable organic solvent) to remove interfering substances and concentrate the analyte.
- Evaporation and Reconstitution: The organic extract is evaporated to dryness and the residue is reconstituted in the mobile phase.

HPLC Conditions:

- Column: A C18 reverse-phase column is typically used.
- Mobile Phase: A mixture of an aqueous buffer (e.g., ammonium formate) and an organic modifier (e.g., acetonitrile) in an isocratic or gradient elution mode.

- Detection: Fluorescence detection is commonly employed due to its high sensitivity and selectivity for quinidine and its metabolites. Excitation and emission wavelengths are optimized for the specific compounds.
- Quantification: A calibration curve is generated using standards of known concentrations of **Quinidine N-oxide**. The concentration in the unknown samples is determined by comparing their peak areas to the calibration curve.

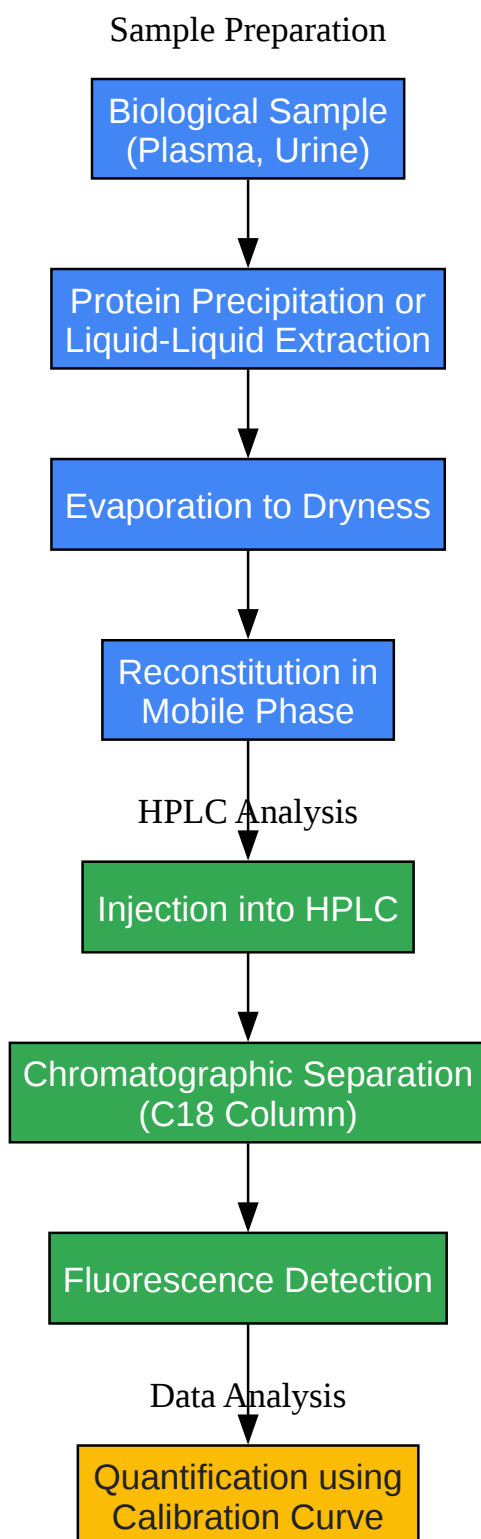

[Click to download full resolution via product page](#)

*Experimental workflow for the quantification of **Quinidine N-oxide**.*

Pharmacological Activity

Studies have investigated the pharmacological activity of **Quinidine N-oxide** to determine its contribution to the overall therapeutic and toxic effects of quinidine. Research indicates that **Quinidine N-oxide** does not possess significant quinidine-like pharmacological activity.[3] Specifically, no systematic changes in the heart rate-corrected QT interval were observed at concentrations up to 500 ng/ml.[3] Furthermore, in experimental models of reperfusion arrhythmia, **Quinidine N-oxide** showed no definite pharmacological activity up to concentrations of 16 mg/l.[4] This is in contrast to other metabolites like 3-hydroxyquinidine, which does exhibit antiarrhythmic effects.[4]

Conclusion

The discovery of **Quinidine N-oxide** as a human metabolite has been a significant step in understanding the complex biotransformation of quinidine. The development of robust analytical methods has enabled its quantification in biological fluids, providing valuable data for pharmacokinetic modeling. While **Quinidine N-oxide** itself appears to be pharmacologically inactive, its formation represents a notable pathway in the clearance of the parent drug. This comprehensive understanding is crucial for optimizing quinidine therapy and for the broader field of drug development, where a thorough characterization of metabolic pathways is paramount.

Need Custom Synthesis?

BenchChem offers custom synthesis for rare earth carbides and specific isotopic labeling.

Email: info@benchchem.com or [Request Quote Online](#).

References

- [1. Isolation, characterisation and synthesis of a new quinidine metabolite - PubMed \[pubmed.ncbi.nlm.nih.gov\]](#)
- [2. caymanchem.com \[caymanchem.com\]](#)
- [3. Kinetics and dynamics of quinidine-N-oxide in healthy subjects - PubMed \[pubmed.ncbi.nlm.nih.gov\]](#)

- [4. Antiarrhythmic activity of two quinidine metabolites in experimental reperfusion arrhythmia: relative potency and pharmacodynamic interaction with the parent drug - PubMed \[pubmed.ncbi.nlm.nih.gov\]](#)
- To cite this document: BenchChem. [The Discovery and Characterization of Quinidine N-oxide: A Technical Guide]. BenchChem, [2026]. [Online PDF]. Available at: [<https://www.benchchem.com/product/b10779014/docs#the-discovery-and-characterization-of-quinidine-n-oxide-a-technical-guide>]

Disclaimer & Data Validity:

The information provided in this document is for Research Use Only (RUO) and is strictly not intended for diagnostic or therapeutic procedures. While BenchChem strives to provide accurate protocols, we make no warranties, express or implied, regarding the fitness of this product for every specific experimental setup.

Technical Support: The protocols provided are for reference purposes. Unsure if this reagent suits your experiment?

Need Industrial/Bulk Grade? [Request Custom Synthesis Quote](#)

BenchChem

Our mission is to be the trusted global source of essential and advanced chemicals, empowering scientists and researchers to drive progress in science and industry.

Contact

Address: 3281 E Guasti Rd
Ontario, CA 91761, United States
Phone: (601) 213-4426
Email: info@benchchem.com

[Contact our Ph.D. Support Team for a compatibility check](#)

