

Technical Support Center: ADCY2 RNAi Off-Target Effects

Author: BenchChem Technical Support Team. **Date:** April 2026

Compound of Interest

Compound Name: *ADCY2 Human Pre-designed
siRNA Set A*

Cat. No.: *B10779516*

[Get Quote](#)

This technical support center provides researchers, scientists, and drug development professionals with comprehensive guidance on identifying, mitigating, and controlling for off-target effects in Adenylyl Cyclase 2 (ADCY2) RNA interference (RNAi) experiments.

Frequently Asked Questions (FAQs)

Q1: What are the primary causes of off-target effects in ADCY2 RNAi experiments?

Off-target effects in RNAi experiments, including those targeting ADCY2, primarily arise from two mechanisms:

- **MicroRNA-like Off-Target Effects:** The siRNA guide strand can bind to unintended mRNA transcripts with partial complementarity, particularly in the "seed region" (nucleotides 2-8 of the guide strand).[1][2][3] This can lead to the translational repression or degradation of unintended genes.[2][3]
- **Passenger Strand Loading:** The passenger (sense) strand of the siRNA duplex can sometimes be loaded into the RNA-Induced Silencing Complex (RISC), leading to the silencing of genes with complementarity to this strand.[2][4]

Additionally, high concentrations of siRNA can saturate the cellular RNAi machinery, leading to non-specific effects.[4][5] Poorly designed siRNA sequences can also contribute significantly to off-target effects.[6]

Q2: How can I design my ADCY2 siRNA to minimize off-target effects from the start?

Proactive siRNA design is a critical first step in minimizing off-target effects. Key strategies include:

- **Bioinformatic Filtering:** Utilize rigorous design algorithms that screen for potential off-target binding sites across the transcriptome.[4][5][7] These algorithms can help avoid sequences with significant homology to other genes.
- **"Safe" Seed Sequences:** Prioritize siRNA sequences with seed regions that have a low frequency of complementary sites within the 3' UTRs of all known human genes.[3]
- **Asymmetric Design:** Design the siRNA duplex so that the guide strand has lower thermodynamic stability at its 5' end. This promotes the preferential loading of the guide strand into RISC, reducing off-target effects caused by the passenger strand.[2][4]

Q3: What experimental strategies can I employ to reduce observed off-target effects?

Several in-lab strategies can be implemented to mitigate off-target effects:

- **siRNA Pooling:** Use a pool of multiple siRNAs that target different regions of the ADCY2 mRNA.[1][2][5][7] This allows for the use of a lower concentration of each individual siRNA, reducing the likelihood of off-target effects from any single sequence while maintaining on-target knockdown efficiency.[1][2][5][7]
- **Chemical Modifications:** Employ chemically modified siRNAs, such as those with 2'-O-methylation or locked nucleic acid (LNA) incorporations, particularly within the seed region. [1][2][8][9] These modifications can destabilize the interaction between the siRNA guide strand and off-target mRNAs without compromising on-target activity.[1][10]
- **Concentration Optimization:** Titrate the siRNA concentration to the lowest effective dose that achieves sufficient ADCY2 knockdown.[4][5][11] Reducing the siRNA concentration can significantly decrease off-target effects.[4][5][11]

Q4: What are the essential controls for an ADCY2 RNAi experiment to properly assess off-target effects?

A robust set of controls is crucial for interpreting your results accurately. Essential controls include:

- **Negative Control siRNA:** A non-targeting siRNA with no known homology to any gene in the target organism is essential to distinguish sequence-specific effects from non-specific cellular responses to the siRNA delivery.[\[12\]](#)[\[13\]](#)[\[14\]](#)
- **Positive Control siRNA:** An siRNA targeting a well-characterized housekeeping gene (e.g., GAPDH) to confirm efficient transfection and knockdown.[\[12\]](#)[\[13\]](#)[\[15\]](#)
- **Untreated Control:** Cells that have not been exposed to any siRNA or transfection reagent to provide a baseline for normal gene expression and phenotype.[\[12\]](#)
- **Multiple siRNAs Targeting ADCY2:** Using at least two or more different siRNAs targeting distinct regions of the ADCY2 mRNA.[\[16\]](#)[\[17\]](#) A consistent phenotype observed with multiple siRNAs strengthens the conclusion that the effect is on-target.[\[16\]](#)

Troubleshooting Guide

Issue	Potential Cause	Recommended Solution
Significant changes in the expression of genes unrelated to the ADCY2 pathway.	MicroRNA-like off-target effects.	<ol style="list-style-type: none">1. Validate with multiple siRNAs: Use at least two different siRNAs targeting ADCY2.[16][17]2. Rescue experiment: Re-introduce an ADCY2 expression vector that is resistant to your siRNA. If the phenotype is rescued, it is likely an on-target effect.3. Perform whole-transcriptome analysis (e.g., RNA-seq): This can help identify the full spectrum of off-target effects. [1]
High cell toxicity or unexpected phenotypes observed with ADCY2 knockdown.	Off-target effects leading to cellular stress or apoptosis. [8]	<ol style="list-style-type: none">1. Lower siRNA concentration: Titrate the siRNA to the lowest effective concentration.[4][11]2. Use chemically modified siRNAs: These are designed to reduce off-target toxicity.[8]3. Switch to an siRNA pool: This reduces the concentration of any single offending siRNA.[2] [7]

Inconsistent results between different ADCY2 siRNAs.

One or more siRNAs may have significant off-target effects.

1. Analyze individual siRNAs: Deconvolute your siRNA pool and test each one individually to identify the problematic sequence(s).
2. Perform bioinformatic analysis: Check the seed region of each siRNA for potential off-target matches.
3. Design new siRNAs: Focus on sequences with minimal predicted off-target potential.[\[3\]](#)

Data Presentation

Table 1: Impact of Mitigation Strategies on Off-Target Effects

Mitigation Strategy	On-Target Knockdown Efficiency	Reduction in Off-Target Gene Regulation	Reference
siRNA Pooling	Maintained or Improved	Significant reduction in the number of off-targeted genes.	[1] [5] [7]
Chemical Modification (e.g., 2'-O-methyl)	Maintained	Up to 80% reduction in off-target activity.	[7] [8]
Lowering siRNA Concentration	May be reduced	Significant reduction in the number and magnitude of off-target effects.	[4] [11]

Experimental Protocols

Protocol 1: siRNA Transfection and Concentration Optimization

- **Cell Seeding:** Plate cells in a 24-well plate at a density that will result in 50-70% confluency at the time of transfection.
- **siRNA Preparation:** Prepare a dilution series of your ADCY2-targeting siRNA and negative control siRNA (e.g., 1, 5, 10, 25, 50 nM).
- **Transfection Complex Formation:** For each concentration, mix the siRNA with a suitable transfection reagent according to the manufacturer's instructions. Incubate to allow for complex formation.
- **Transfection:** Add the siRNA-transfection reagent complexes to the cells.
- **Incubation:** Incubate the cells for 24-72 hours.
- **Analysis:** Harvest the cells and assess ADCY2 mRNA and protein levels (e.g., via qPCR and Western blot) to determine the lowest siRNA concentration that provides sufficient knockdown.

Protocol 2: Validating On-Target Effects using a Rescue Experiment

- **Construct Design:** Clone the full-length ADCY2 cDNA into an expression vector. Introduce silent mutations in the siRNA target site to make the transcript resistant to the siRNA while still producing the wild-type protein.
- **Co-transfection:** Transfect cells with the ADCY2-targeting siRNA along with either the siRNA-resistant ADCY2 expression vector or an empty vector control.
- **Phenotypic Analysis:** After an appropriate incubation period, assess the phenotype of interest.
- **Interpretation:** If the phenotype observed with the ADCY2 siRNA is reversed by the expression of the siRNA-resistant ADCY2, it confirms that the phenotype is due to the on-target knockdown of ADCY2.

Visualizations

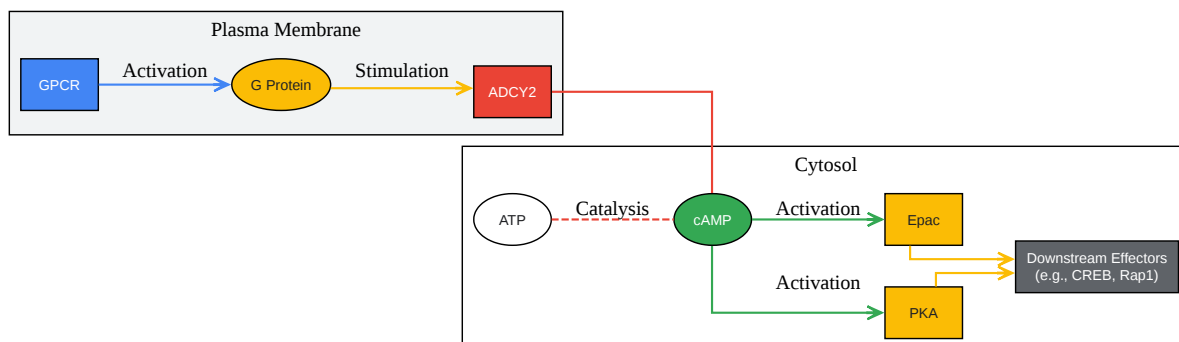

[Click to download full resolution via product page](#)

Caption: Classical ADCY2 signaling pathway.[18][19]

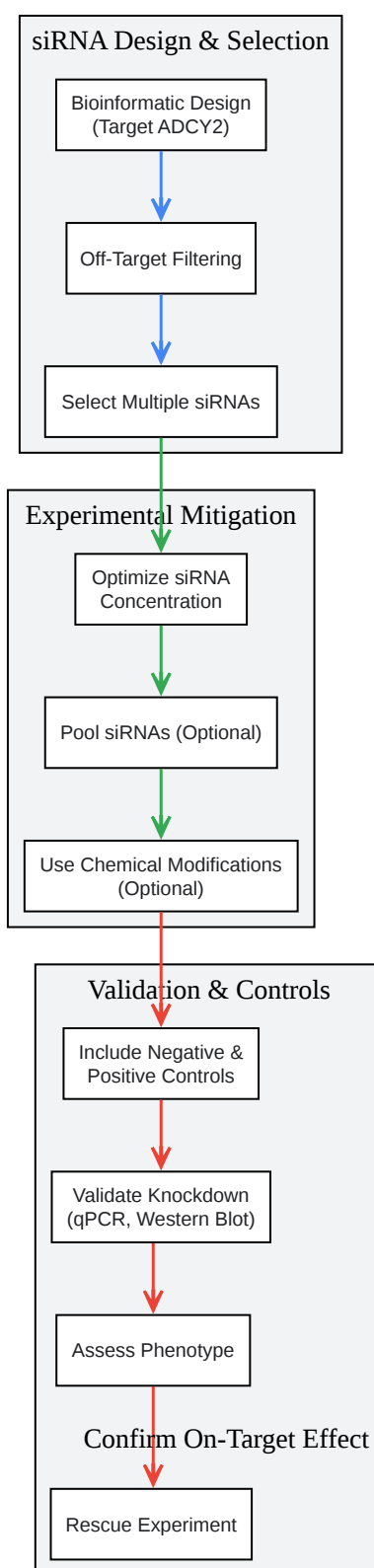

[Click to download full resolution via product page](#)

Caption: Experimental workflow for mitigating off-target effects.

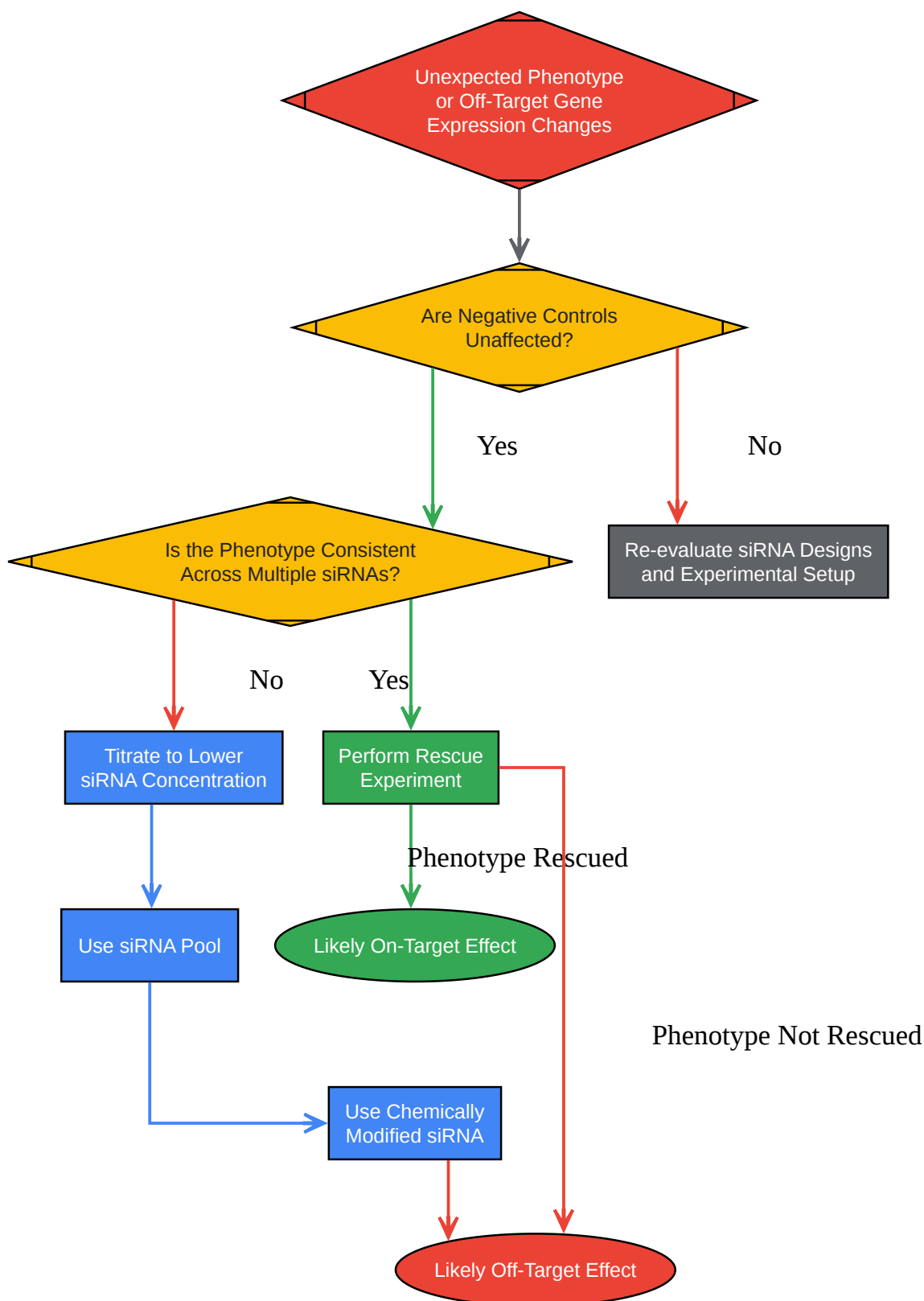

[Click to download full resolution via product page](#)

Need Custom Synthesis?

BenchChem offers custom synthesis for rare earth carbides and specific isotopic labeling.

Email: info@benchchem.com or [Request Quote Online](#).

References

- [1. siRNA Specificity: RNAi Mechanisms and Strategies to Reduce Off-Target Effects - PMC \[pmc.ncbi.nlm.nih.gov\]](#)
- [2. Methods for reducing siRNA off-target binding | Eclipsebio \[eclipsebio.com\]](#)
- [3. Rational Design of Therapeutic siRNAs: Minimizing Off-targeting Potential to Improve the Safety of RNAi Therapy for Huntington's Disease - PMC \[pmc.ncbi.nlm.nih.gov\]](#)
- [4. sitoolsbiotech.com \[sitoolsbiotech.com\]](#)
- [5. horizondiscovery.com \[horizondiscovery.com\]](#)
- [6. What are the key parameters contributing to unwanted off-target effects in an RNAi experiment? \[qiagen.com\]](#)
- [7. Reducing off-target effects in RNA interference experiments \[horizondiscovery.com\]](#)
- [8. Off-target effects by siRNA can induce toxic phenotype - PMC \[pmc.ncbi.nlm.nih.gov\]](#)
- [9. Controlling miRNA-like off-target effects of an siRNA with nucleobase modifications - Organic & Biomolecular Chemistry \(RSC Publishing\) \[pubs.rsc.org\]](#)
- [10. Structure-Guided Control of siRNA Off-Target Effects - PMC \[pmc.ncbi.nlm.nih.gov\]](#)
- [11. siRNA Off-Target Effects Can Be Reduced at Concentrations That Match Their Individual Potency | PLOS One \[journals.plos.org\]](#)
- [12. horizondiscovery.com \[horizondiscovery.com\]](#)
- [13. Controls for RNAi Experiments | Thermo Fisher Scientific - HK \[thermofisher.com\]](#)
- [14. RNAi How To for New Users | Thermo Fisher Scientific - AR \[thermofisher.com\]](#)
- [15. Top three tips for troubleshooting your RNAi experiment \[horizondiscovery.com\]](#)
- [16. pubs.acs.org \[pubs.acs.org\]](#)
- [17. RNAi screening: tips and techniques - PMC \[pmc.ncbi.nlm.nih.gov\]](#)
- [18. researchgate.net \[researchgate.net\]](#)
- [19. ADCY2 - Wikipedia \[en.wikipedia.org\]](#)

- To cite this document: BenchChem. [Technical Support Center: ADCY2 RNAi Off-Target Effects]. BenchChem, [2026]. [Online PDF]. Available at: [<https://www.benchchem.com/product/b10779516/docs#technical-support-center-adcy2-rnai-off-target-effects>]

Disclaimer & Data Validity:

The information provided in this document is for Research Use Only (RUO) and is strictly not intended for diagnostic or therapeutic procedures. While BenchChem strives to provide accurate protocols, we make no warranties, express or implied, regarding the fitness of this product for every specific experimental setup.

Technical Support: The protocols provided are for reference purposes. Unsure if this reagent suits your experiment?

Need Industrial/Bulk Grade? [Request Custom Synthesis Quote](#)

BenchChem

Our mission is to be the trusted global source of essential and advanced chemicals, empowering scientists and researchers to drive progress in science and industry.

Contact

Address: 3281 E Guasti Rd
Ontario, CA 91761, United States
Phone: (601) 213-4426
Email: info@benchchem.com

[Contact our Ph.D. Support Team for a compatibility check](#)