

# RG13022 for In Vivo Studies: A Technical Guide

**Author:** BenchChem Technical Support Team. **Date:** April 2026

## Compound of Interest

Compound Name: *RG13022*  
Cat. No.: *B10779546*

[Get Quote](#)

For Researchers, Scientists, and Drug Development Professionals

## Introduction

**RG13022**, a tyrphostin derivative, is a potent inhibitor of the epidermal growth factor receptor (EGFR) tyrosine kinase. The overactivation of EGFR is a hallmark of numerous cancers, making it a prime target for therapeutic intervention. This technical guide provides an in-depth overview of the in vivo applications of **RG13022**, consolidating key experimental data and protocols to facilitate further research and drug development. The information presented herein is intended for a scientific audience and summarizes publicly available preclinical data.

## Mechanism of Action

**RG13022** exerts its biological effects by competitively binding to the ATP-binding site within the tyrosine kinase domain of the EGFR. This inhibition blocks the autophosphorylation of the receptor, a critical step in the activation of downstream signaling pathways. By attenuating EGFR signaling, **RG13022** can suppress cancer cell proliferation and survival.

## In Vitro Efficacy

A substantial body of in vitro data demonstrates the inhibitory activity of **RG13022** across various cellular assays and cell lines. The half-maximal inhibitory concentrations (IC<sub>50</sub>) provide

a quantitative measure of its potency.

Assay Type	Cell Line	IC50 (µM)	Reference
EGFR Autophosphorylation	Cell-free	4	[1]
EGFR Autophosphorylation	HER 14	5	[2]
Colony Formation	HER 14	1	[1][2]
DNA Synthesis	HER 14	3	[1][2]
Colony Formation	MH-85	7	[2]
DNA Synthesis	MH-85	1.5	[2]

## In Vivo Studies in Xenograft Models

In vivo studies using nude mice bearing human tumor xenografts have demonstrated the anti-tumor efficacy of **RG13022**. A key study investigated its effects on a human squamous cell carcinoma cell line, MH-85.

### Experimental Protocol: MH-85 Xenograft Model

This section details the methodology for evaluating the in vivo efficacy of **RG13022** in a nude mouse xenograft model.

#### 1. Animal Model:

- Species: Athymic nude mice (nu/nu). These mice lack a functional thymus and are T-cell deficient, preventing the rejection of human tumor xenografts.[3][4]

#### 2. Tumor Cell Inoculation:

- Cell Line: MH-85, a human squamous cell carcinoma cell line.
- Cell Preparation: MH-85 cells are cultured in appropriate media, harvested during the exponential growth phase, and resuspended in a sterile physiological solution (e.g.,

phosphate-buffered saline).

- Inoculation: A suspension of  $5 \times 10^6$  MH-85 cells in 0.2 mL is injected subcutaneously into the subscapular region of the mice.

### 3. **RG13022** Formulation and Administration:

- Formulation: **RG13022** is dissolved in a vehicle suitable for in vivo administration. A common solvent for similar compounds is dimethyl sulfoxide (DMSO). For injection, the DMSO stock is often diluted with other vehicles like polyethylene glycol (PEG), Tween-80, and saline to improve solubility and reduce toxicity.[5] A typical formulation might be 10% DMSO, 40% PEG300, 5% Tween-80, and 45% saline.[5]
- Dosage: 400  $\mu$ g/mouse/day .[2]
- Route of Administration: Intraperitoneal (i.p.) injection.
- Frequency and Duration: Daily injections for a specified period, for example, 14 consecutive days, starting the day after tumor cell inoculation.[2]

### 4. Monitoring and Endpoints:

- Tumor Growth: Tumor size is measured regularly (e.g., twice weekly) using calipers. Tumor volume can be calculated using the formula:  $(\text{length} \times \text{width}^2) / 2$ .
- Animal Well-being: Animals are monitored for signs of toxicity, including weight loss, changes in behavior, and overall health.
- Survival: The lifespan of the mice in the treatment and control groups is recorded.
- Primary Endpoint: Significant inhibition of tumor growth in the **RG13022**-treated group compared to the vehicle-treated control group.
- Secondary Endpoint: Increased lifespan of the tumor-bearing mice in the **RG13022**-treated group.

## In Vivo Efficacy Results

In the MH-85 xenograft model, administration of **RG13022** at a dose of 400  $\mu$ g/mouse/day resulted in:

- Significant inhibition of tumor growth.[2]
- Prolonged lifespan of the tumor-bearing animals.[2]

It is important to note that pharmacokinetic studies have shown that **RG13022** has rapid in vivo elimination. This suggests that the administration schedule, including the frequency of injections or the use of continuous administration, is a critical factor in achieving sustained therapeutic concentrations and maximizing anti-tumor efficacy.

## Signaling Pathway

**RG13022** targets the EGFR signaling pathway, which is a complex network that regulates cell proliferation, survival, and differentiation. Inhibition of EGFR by **RG13022** blocks the activation of key downstream signaling cascades, including the RAS-RAF-MEK-ERK (MAPK) pathway and the PI3K-AKT-mTOR pathway.

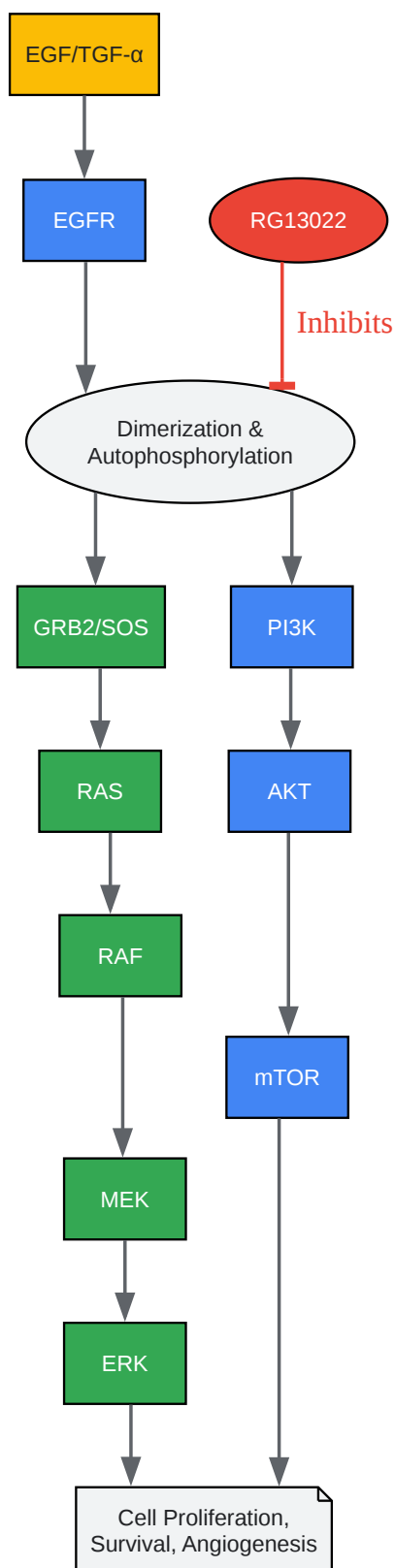

[Click to download full resolution via product page](#)

Caption: EGFR signaling pathway and the inhibitory action of **RG13022**.

## Conclusion

**RG13022** is a well-characterized EGFR tyrosine kinase inhibitor with demonstrated anti-proliferative effects in both in vitro and in vivo models of cancer. The data summarized in this guide provide a valuable resource for researchers investigating the therapeutic potential of **RG13022** and for designing further preclinical studies. The detailed experimental protocol for in vivo evaluation offers a practical framework for assessing the efficacy of this and similar compounds. Future research should consider the pharmacokinetic properties of **RG13022** to optimize dosing strategies and maximize its therapeutic window.

### Need Custom Synthesis?

BenchChem offers custom synthesis for rare earth carbides and specific isotopic labeling.

Email: [info@benchchem.com](mailto:info@benchchem.com) or [Request Quote Online](#).

## References

- [1. medchemexpress.com \[medchemexpress.com\]](https://www.medchemexpress.com)
- [2. Frontiers | Targeting the Immune System to Fight Cancer Using Chemical Receptor Homing Vectors Carrying Polyinosine/Cytosine \(PolyIC\) \[frontiersin.org\]](https://www.frontiersin.org)
- [3. An in vivo model for squamous cell carcinoma of the head and neck - PubMed \[pubmed.ncbi.nlm.nih.gov\]](https://pubmed.ncbi.nlm.nih.gov)
- [4. RG13022 | EGFR | TargetMol \[targetmol.com\]](https://www.targetmol.com)
- [5. google.com \[google.com\]](https://www.google.com)
- To cite this document: BenchChem. [RG13022 for In Vivo Studies: A Technical Guide]. BenchChem, [2026]. [Online PDF]. Available at: [\[https://www.benchchem.com/product/b10779546/docs#rg13022-for-in-vivo-studies-a-technical-guide\]](https://www.benchchem.com/product/b10779546/docs#rg13022-for-in-vivo-studies-a-technical-guide)

---

### Disclaimer & Data Validity:

The information provided in this document is for Research Use Only (RUO) and is strictly not intended for diagnostic or therapeutic procedures. While BenchChem strives to provide

accurate protocols, we make no warranties, express or implied, regarding the fitness of this product for every specific experimental setup.

**Technical Support:** The protocols provided are for reference purposes. Unsure if this reagent suits your experiment?

**Need Industrial/Bulk Grade?** [Request Custom Synthesis Quote](#)

## BenchChem

Our mission is to be the trusted global source of essential and advanced chemicals, empowering scientists and researchers to drive progress in science and industry.

### Contact

Address: 3281 E Guasti Rd

Ontario, CA 91761, United States

Phone: (601) 213-4426

Email: [info@benchchem.com](mailto:info@benchchem.com)

[Contact our Ph.D. Support Team for a compatibility check](#)