

Application Notes and Protocols for Patch-Clamp Studies Involving Quinidine

Author: BenchChem Technical Support Team. **Date:** April 2026

Compound of Interest

Compound Name: Quinidine N-oxide

Cat. No.: B10779067

[Get Quote](#)

For Researchers, Scientists, and Drug Development Professionals

These application notes provide a comprehensive guide for conducting patch-clamp electrophysiology experiments to investigate the effects of quinidine on various ion channels. Quinidine, a classic class I antiarrhythmic agent, is a well-characterized blocker of multiple ion channels, making it a crucial tool in cardiac electrophysiology research and a reference compound in drug safety studies.

Mechanism of Action

Quinidine's primary mechanism of action is the direct blockade of voltage-gated ion channels. Its effects are complex and concentration-dependent, with significant interactions reported for sodium, potassium, and calcium channels. This multi-channel blockade underlies both its therapeutic antiarrhythmic effects and its potential proarrhythmic risk.^[1]

Sodium Channel (Nav) Blockade: Quinidine blocks the fast inward sodium current (I_{Na}), which is responsible for the rapid depolarization (Phase 0) of the cardiac action potential.^[1] This block is "use-dependent," meaning it becomes more pronounced at higher stimulation frequencies, a characteristic feature of its interaction with the Nav1.5 channel.^[2] Quinidine

exhibits a low affinity for the rested state of the channel and a higher affinity for the open and inactivated states.[3]

Potassium Channel (Kv) Blockade: Quinidine is a potent blocker of several potassium channels, most notably the human Ether-à-go-go-Related Gene (hERG) channel, which conducts the rapid component of the delayed rectifier potassium current (IKr).[4][5][6] Blockade of IKr prolongs the action potential duration (APD) and the QT interval on an electrocardiogram. Additionally, quinidine can block other potassium channels, including the transient outward current (Ito).[1]

Calcium Channel (Cav) Blockade: Quinidine can also reversibly block L-type calcium currents (ICaL), which contributes to its overall electrophysiological profile.[7] This effect can modulate the plateau phase of the cardiac action potential.

Quantitative Data: Inhibitory Potency of Quinidine

The half-maximal inhibitory concentration (IC50) of quinidine varies depending on the specific ion channel subtype, the expression system, and the experimental conditions. The following tables summarize reported IC50 values for key cardiac ion channels.

Sodium Channel	Current	Species/Expression System	IC50 (μM)	Reference
hNav1.5	Peak INa	HEK293 cells	28.9 ± 2.2	[8]
hNav1.5	Late INa	HEK293 cells	Varies with protocol	[9]

Potassium Channel	Current	Species/Expression System	IC50 (μM)	Reference
hERG (Kv11.1)	IKr	CHO cells	0.32 ± 0.03	[10]
hKv1.5	-	HEK293 cells	7.2 (at +60 mV)	
Kv1.4	-	Xenopus oocytes	~80 (for 49% block)	[11]

Calcium Channel	Current	Species/Expression System	IC50 (μ M)	Reference
Cav1.2	ICaL	-	Varies	[7]

Experimental Protocols

Detailed methodologies are crucial for obtaining reproducible and reliable data in patch-clamp experiments. Below are representative protocols for whole-cell voltage-clamp recordings.

Protocol 1: Whole-Cell Voltage-Clamp Recording of hNav1.5 Channels

This protocol is designed to assess the tonic and use-dependent block of human Nav1.5 channels expressed in a mammalian cell line (e.g., HEK293).[12]

A. Cell Preparation:

- Culture HEK293 cells stably expressing hNav1.5 in appropriate culture medium.
- Plate the cells onto glass coverslips 24-48 hours prior to the experiment to achieve 50-70% confluency.
- On the day of the experiment, transfer a coverslip to the recording chamber on the microscope stage.

B. Solutions:

- External Solution (in mM): 140 NaCl, 4 KCl, 2 CaCl₂, 1 MgCl₂, 10 HEPES, 10 Glucose. Adjust pH to 7.4 with NaOH.[12]
- Internal (Pipette) Solution (in mM): 120 CsF, 20 CsCl, 10 NaCl, 10 HEPES, 10 EGTA. Adjust pH to 7.2 with CsOH.[12]
- Quinidine Stock Solution: Prepare a 10 mM stock solution of quinidine in DMSO. Dilute to the final desired concentrations in the external solution on the day of the experiment. Ensure the final DMSO concentration does not exceed 0.1%.[12]

C. Recording Procedure:

- Pull patch pipettes from borosilicate glass capillaries to a resistance of 2-4 M Ω when filled with the internal solution.[12]
- Establish a giga-ohm seal (>1 G Ω) with a target cell.[12]
- Rupture the cell membrane to achieve the whole-cell configuration.[12]
- Allow the cell to stabilize for 5-10 minutes before initiating recordings.
- Perform recordings at room temperature (22-25 °C).

D. Voltage Protocols:

- Tonic Block:
 - Hold the membrane potential at -120 mV.
 - Apply a 50 ms depolarizing pulse to -20 mV every 30 seconds to elicit the peak sodium current.
 - After establishing a stable baseline, perfuse the cell with the quinidine-containing external solution.
 - Continue recording until the blocking effect reaches a steady state.
- Use-Dependent Block:
 - Hold the membrane potential at -120 mV.
 - Apply a train of 20 depolarizing pulses to -20 mV for 20 ms at a frequency of 1 Hz or 5 Hz.
 - Record the peak current for each pulse in the train.
 - After a washout period, perfuse the cell with the quinidine-containing external solution and repeat the pulse train.

E. Data Analysis:

- Measure the peak inward current for each pulse.
- Tonic Block Calculation: % Block = $(1 - I_{\text{Quinidine}} / I_{\text{Control}}) * 100$, where I is the peak current in the presence and absence of quinidine.[12]
- Use-Dependent Block Analysis: Normalize the peak current of each pulse to the peak current of the first pulse in the train. Plot the normalized current against the pulse number to visualize the development of use-dependent block.

Protocol 2: Whole-Cell Voltage-Clamp Recording of hERG Channels

This protocol is for assessing the block of hERG channels expressed in a suitable cell line.

A. Cell Preparation:

- Follow the same cell culture and plating procedures as for Nav1.5, using a cell line stably expressing hERG channels.

B. Solutions:

- External Solution (in mM): 145 NaCl, 4 KCl, 2 CaCl₂, 1 MgCl₂, 10 HEPES, 10 Glucose. Adjust pH to 7.4 with NaOH.
- Internal (Pipette) Solution (in mM): 120 KF, 20 KCl, 10 HEPES, 10 EGTA. Adjust pH to 7.2 with KOH.[10]
- Quinidine Stock Solution: Prepare as described in Protocol 1.

C. Recording Procedure:

- Follow the same recording procedure as for Nav1.5.

D. Voltage Protocol:

- Hold the membrane potential at -80 mV.

- Apply a depolarizing step to +20 mV for 2 seconds to activate and then inactivate the channels.
- Repolarize to -50 mV for 2 seconds to record the deactivating tail current, which is used to quantify hERG current amplitude.
- Repeat this protocol at a regular interval (e.g., every 15 seconds) to establish a stable baseline before and during quinidine application.

E. Data Analysis:

- Measure the peak tail current amplitude at -50 mV.
- Calculate the percentage of block as described for the tonic block in Protocol 1.
- Construct concentration-response curves by plotting the percentage of block against the quinidine concentration and fit with the Hill equation to determine the IC₅₀.

Signaling Pathways and Experimental Workflows

The primary interaction of quinidine with ion channels is a direct physical blockade of the pore. However, the functional consequences of this blockade can be understood in the context of the channel's gating states and the overall experimental workflow.

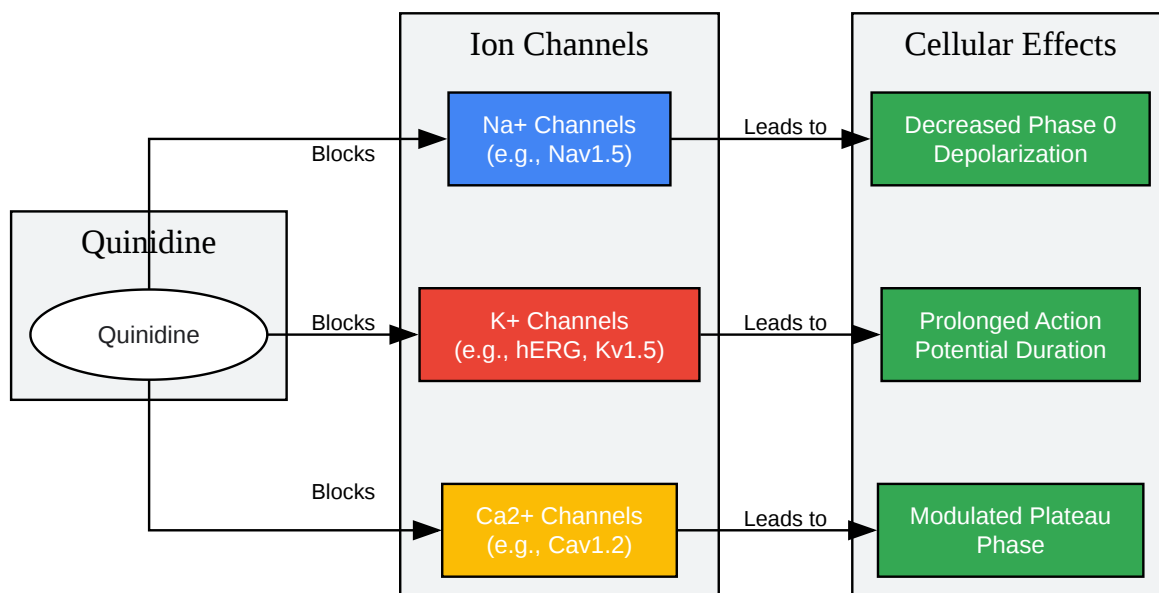

[Click to download full resolution via product page](#)

Quinidine's multi-channel blocking effects.

The following diagram illustrates a typical experimental workflow for a patch-clamp study investigating an ion channel blocker like quinidine.

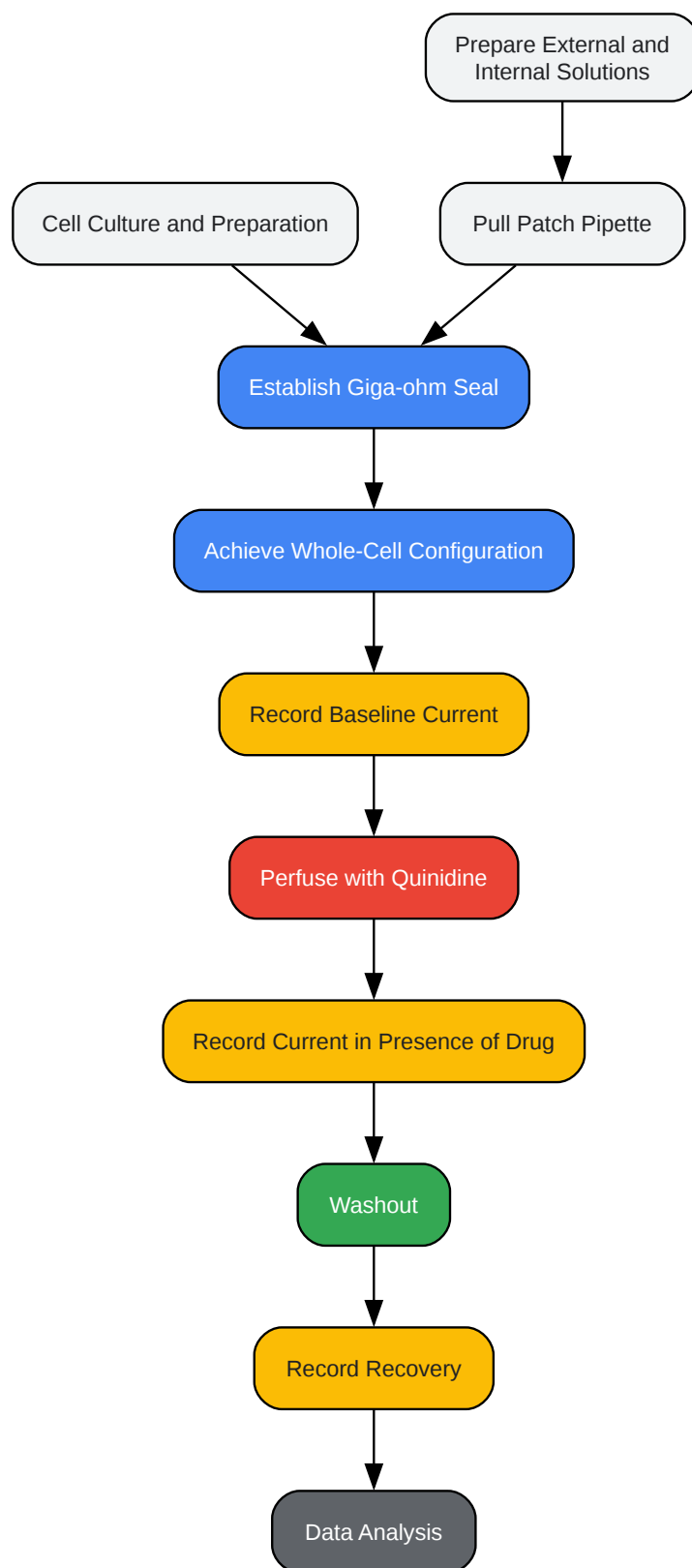

[Click to download full resolution via product page](#)

A typical patch-clamp experimental workflow.

Quinidine's blockade of sodium channels is state-dependent, with higher affinity for open and inactivated states. This relationship can be visualized as follows:

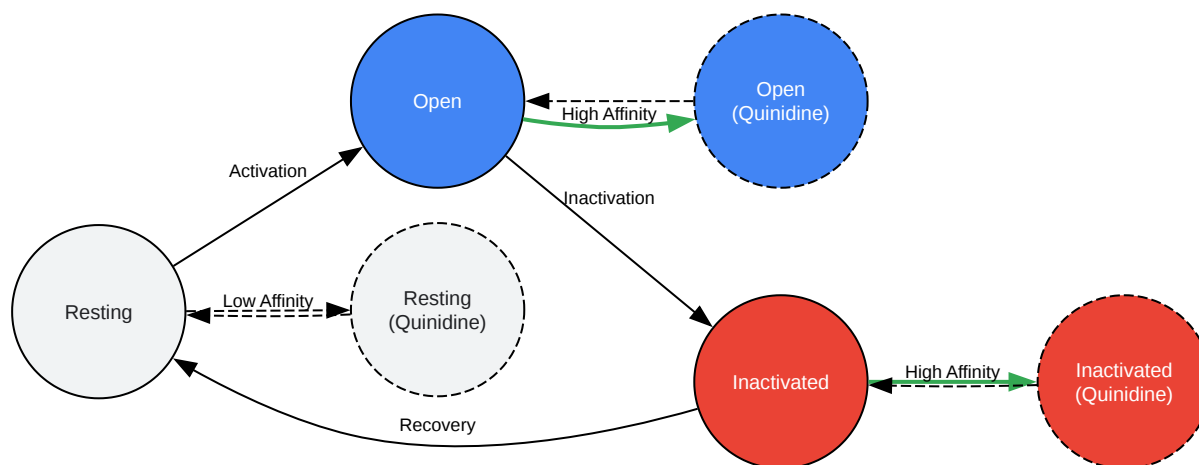

[Click to download full resolution via product page](#)

State-dependent blockade of sodium channels by quinidine.

Need Custom Synthesis?

BenchChem offers custom synthesis for rare earth carbides and specific isotopic labeling.

Email: info@benchchem.com or [Request Quote Online](#).

References

- 1. go.drugbank.com [go.drugbank.com]
- 2. Quinidine blocks cardiac sodium channels during opening and slow inactivation in guinea-pig papillary muscle - PMC [pmc.ncbi.nlm.nih.gov]
- 3. Quinidine blocks cardiac sodium channels during opening and slow inactivation in guinea-pig papillary muscle - PubMed [pubmed.ncbi.nlm.nih.gov]
- 4. Extracellular potassium dependency of block of HERG by quinidine and cisapride is primarily determined by the permeant ion and not by inactivation - PubMed [pubmed.ncbi.nlm.nih.gov]

- 5. Comparison of kinetic properties of quinidine and dofetilide block of HERG channels - PubMed [pubmed.ncbi.nlm.nih.gov]
- 6. Stereoselective Blockage of Quinidine and Quinine in the hERG Channel and the Effect of Their Rescue Potency on Drug-Induced hERG Trafficking Defect - PubMed [pubmed.ncbi.nlm.nih.gov]
- 7. Effects of quinidine on action potentials and ionic currents in isolated canine ventricular myocytes - PubMed [pubmed.ncbi.nlm.nih.gov]
- 8. researchgate.net [researchgate.net]
- 9. researchgate.net [researchgate.net]
- 10. sophion.com [sophion.com]
- 11. Kv1.4 channel block by quinidine: evidence for a drug-induced allosteric effect - PMC [pmc.ncbi.nlm.nih.gov]
- 12. benchchem.com [benchchem.com]
- To cite this document: BenchChem. [Application Notes and Protocols for Patch-Clamp Studies Involving Quinidine]. BenchChem, [2026]. [Online PDF]. Available at: [https://www.benchchem.com/product/b10779067/docs#application-notes-and-protocols-for-patch-clamp-studies-involving-quinidine]

Disclaimer & Data Validity:

The information provided in this document is for Research Use Only (RUO) and is strictly not intended for diagnostic or therapeutic procedures. While BenchChem strives to provide accurate protocols, we make no warranties, express or implied, regarding the fitness of this product for every specific experimental setup.

Technical Support: The protocols provided are for reference purposes. Unsure if this reagent suits your experiment?

Need Industrial/Bulk Grade? [Request Custom Synthesis Quote](#)

BenchChem

Our mission is to be the trusted global source of essential and advanced chemicals, empowering scientists and researchers to drive progress in science and industry.

Contact

Address: 3281 E Guasti Rd
Ontario, CA 91761, United States
Phone: (601) 213-4426
Email: info@benchchem.com

[Contact our Ph.D. Support Team for a compatibility check](#)