

Application Notes: Visualizing ADCY2 mRNA Knockdown Using Chromogenic In Situ Hybridization

Author: BenchChem Technical Support Team. **Date:** April 2026

Compound of Interest

Compound Name: ADCY2 Human Pre-designed
siRNA Set A

Cat. No.: B10779505

[Get Quote](#)

Introduction

Adenylyl cyclase 2 (ADCY2) is a membrane-bound enzyme that catalyzes the conversion of ATP to cyclic AMP (cAMP), a crucial secondary messenger in numerous cellular signaling pathways.[1][2][3] Dysregulation of ADCY2 has been implicated in various neurological and psychiatric disorders, making it a significant target for therapeutic development.[2][4] Evaluating the efficacy of novel drug candidates, such as small interfering RNAs (siRNAs) designed to silence ADCY2 expression, requires robust methods to visualize and quantify target mRNA knockdown within the cellular context.

In situ hybridization (ISH) is a powerful technique that allows for the precise localization and semi-quantitative analysis of specific nucleic acid sequences within morphologically preserved cells or tissue sections.[5][6] This application note provides a detailed protocol for using chromogenic in situ hybridization (CISH) to visualize and assess the knockdown of ADCY2 mRNA in cultured cells following siRNA treatment.

ADCY2 Signaling Pathway

ADCY2 is an integral component of G-protein coupled receptor (GPCR) signaling cascades. Upon GPCR activation, the G protein beta-gamma ($G\beta\gamma$) subunit complex stimulates ADCY2 activity.[1] Additionally, Protein Kinase C (PKC) can activate ADCY2, leading to the localized production of cAMP.[4] This cAMP then activates downstream effectors like Protein Kinase A (PKA) and Exchange proteins directly activated by cAMP (Epac), which in turn modulate transcription factors and other cellular processes.[2][7]

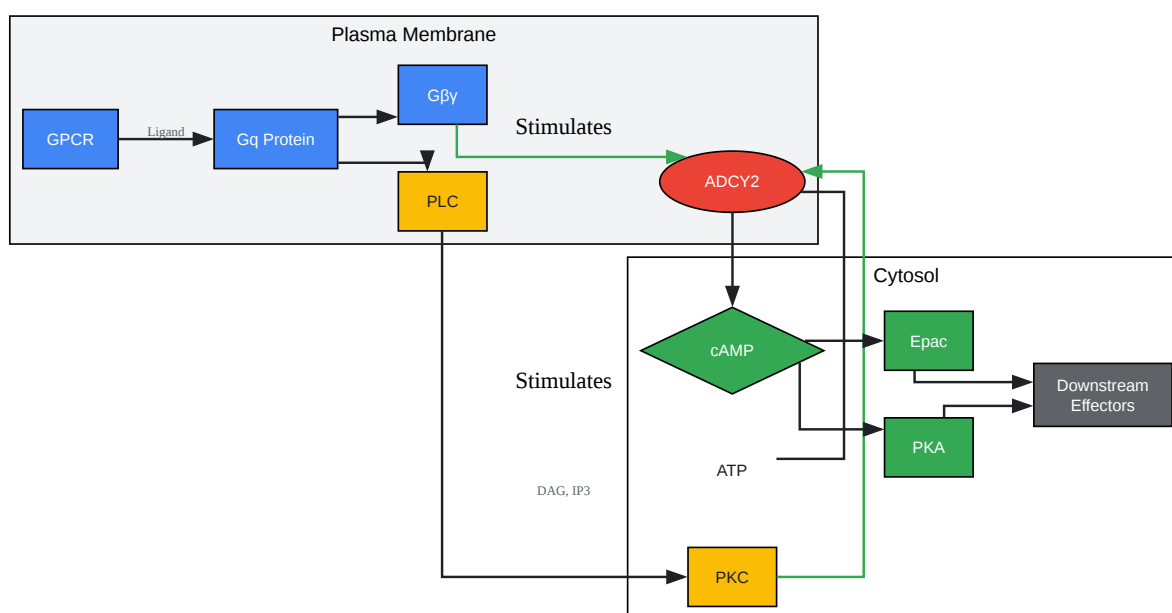

[Click to download full resolution via product page](#)

Figure 1. Simplified ADCY2 signaling cascade.

Experimental Principle and Workflow

The experiment aims to quantify the reduction of ADCY2 mRNA following treatment with a specific siRNA. This is achieved by comparing the CISH signal in cells treated with a non-targeting control siRNA versus an ADCY2-targeting siRNA. The core principle involves hybridizing a labeled antisense nucleic acid probe to the target ADCY2 mRNA within fixed cells. The probe's label is then detected using an enzyme-conjugated antibody, which catalyzes a colorimetric reaction, producing a visible precipitate at the site of mRNA expression. The intensity of this color is proportional to the amount of target mRNA present.

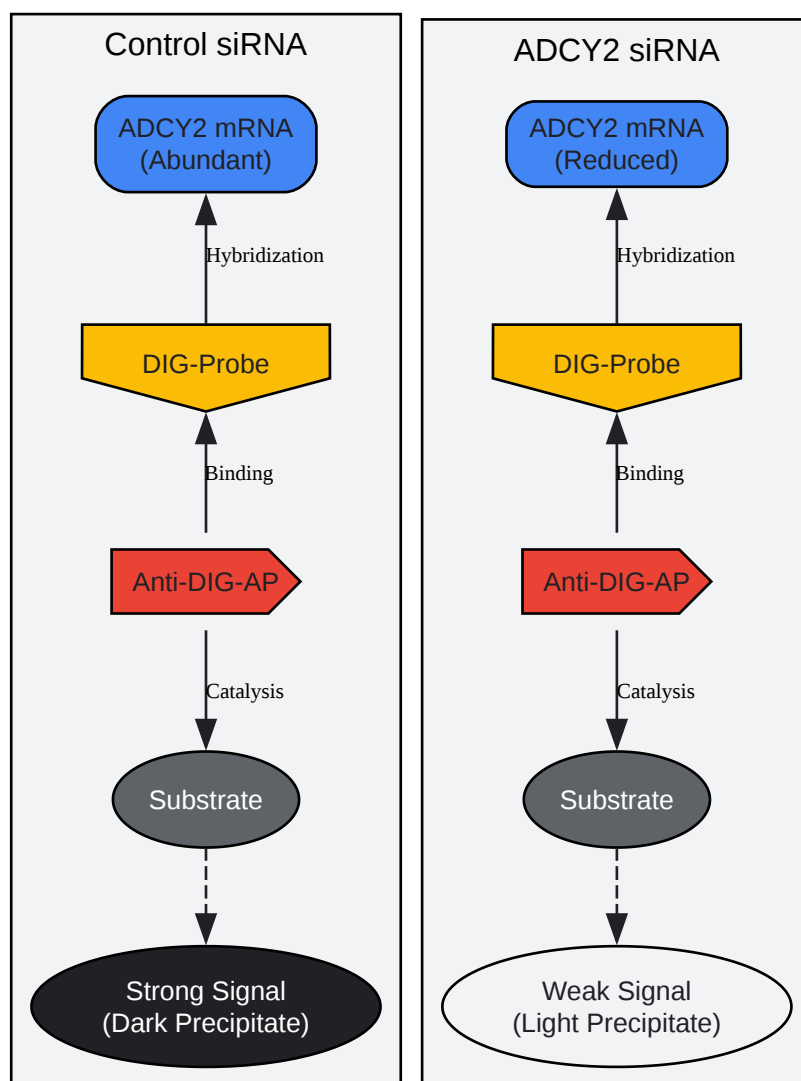

[Click to download full resolution via product page](#)

Figure 2. Principle of CISH for mRNA knockdown detection.

The overall workflow involves cell culture, siRNA transfection, cell fixation, in situ hybridization, signal detection, imaging, and finally, quantitative analysis of the resulting signal.

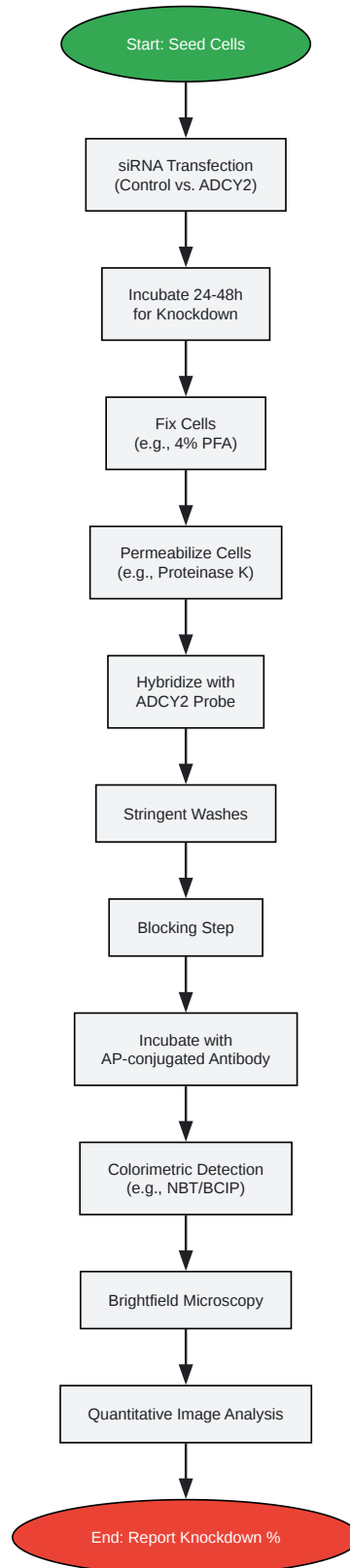

[Click to download full resolution via product page](#)

Need Custom Synthesis?

BenchChem offers custom synthesis for rare earth carbides and specific isotopic labeling.

Email: info@benchchem.com or [Request Quote Online](#).

References

- [1. ADCY2 - Wikipedia \[en.wikipedia.org\]](#)
- [2. Adenylyl cyclase 2 expression and function in neurological diseases - PMC \[pmc.ncbi.nlm.nih.gov\]](#)
- [3. uniprot.org \[uniprot.org\]](#)
- [4. Gene - ADCY2 \[maayanlab.cloud\]](#)
- [5. creative-diagnostics.com \[creative-diagnostics.com\]](#)
- [6. In Situ Hybridization Protocols and Methods | Springer Nature Experiments \[experiments.springernature.com\]](#)
- [7. researchgate.net \[researchgate.net\]](#)
- To cite this document: BenchChem. [Application Notes: Visualizing ADCY2 mRNA Knockdown Using Chromogenic In Situ Hybridization]. BenchChem, [2026]. [Online PDF]. Available at: [<https://www.benchchem.com/product/b10779505/docs#application-notes-visualizing-adcy2-mrna-knockdown-using-chromogenic-in-situ-hybridization>]

Disclaimer & Data Validity:

The information provided in this document is for Research Use Only (RUO) and is strictly not intended for diagnostic or therapeutic procedures. While BenchChem strives to provide accurate protocols, we make no warranties, express or implied, regarding the fitness of this product for every specific experimental setup.

Technical Support: The protocols provided are for reference purposes. Unsure if this reagent suits your experiment?

Need Industrial/Bulk Grade? [Request Custom Synthesis Quote](#)

BenchChem

Our mission is to be the trusted global source of essential and advanced chemicals, empowering scientists and researchers to drive progress in science and industry.

Contact

Address: 3281 E Guasti Rd

Ontario, CA 91761, United States

Phone: (601) 213-4426

Email: info@benchchem.com

[Contact our Ph.D. Support Team for a compatibility check](#)