

# Application Notes and Protocols for Leptomycin A Immunofluorescence Staining

**Author:** BenchChem Technical Support Team. **Date:** April 2026

## Compound of Interest

Compound Name: *Leptomycin A*

Cat. No.: *B10776095*

[Get Quote](#)

## For Researchers, Scientists, and Drug Development Professionals

This document provides a detailed protocol for immunofluorescence (IF) staining of cells treated with **Leptomycin A**, a potent inhibitor of nuclear export. These application notes will guide researchers in visualizing the subcellular localization of proteins that are exported from the nucleus via the CRM1/XPO1-dependent pathway.

## Introduction

**Leptomycin A** and its more potent analog, Leptomycin B (LMB), are invaluable tools for studying the nucleocytoplasmic shuttling of proteins.<sup>[1][2]</sup> These molecules act as specific inhibitors of the Chromosome Region Maintenance 1 (CRM1) protein, also known as Exportin 1 (XPO1).<sup>[1][2]</sup> CRM1 is the major receptor for the nuclear export of a wide range of proteins and RNAs that contain a nuclear export signal (NES).<sup>[1][2]</sup> By binding covalently to a critical cysteine residue (Cys528) in the NES-binding groove of CRM1, **Leptomycin A** effectively blocks the interaction between CRM1 and its cargo, leading to the nuclear accumulation of NES-containing proteins.<sup>[3][4]</sup> This protocol details the application of **Leptomycin A** in conjunction with immunofluorescence microscopy to observe this phenomenon.

## Mechanism of Action

The CRM1/XPO1-mediated nuclear export is a fundamental process in eukaryotic cells, regulating the function of numerous proteins, including tumor suppressors and cell cycle regulators. The process is initiated in the nucleus where CRM1, in complex with the GTP-bound form of the Ran GTPase (RanGTP), recognizes and binds to the NES of a cargo protein. This ternary complex is then translocated through the nuclear pore complex (NPC) into the cytoplasm. In the cytoplasm, RanGTP is hydrolyzed to RanGDP, leading to the disassembly of the export complex and the release of the cargo protein. **Leptomycin A** disrupts this cycle by irreversibly binding to CRM1, preventing the initial recognition of the NES-cargo protein in the nucleus.

## Data Presentation

The following table summarizes typical experimental parameters and expected outcomes for **Leptomycin A/B** treatment in cell culture for immunofluorescence studies.

Parameter	Value	Expected Outcome	Reference
Cell Line	A549 (Human Lung Carcinoma)	---	[3]
Treatment	Leptomycin B (LMB)	---	[3]
Concentration	50 nM	Inhibition of nuclear export	[3]
Incubation Time	4 hours	Nuclear accumulation of CRM1 cargo proteins	[3]
Observed Effect on CRM1	Redistribution from the nucleus to the cytoplasm, with concentration at the nuclear envelope.	A significant decrease in nuclear CRM1 coupled with an increase in cytoplasmic CRM1.	[3]
General Concentration Range	1-20 nM (for Leptomycin B)	Inhibition of most nuclear export	[1]
General Incubation Time	3 hours (for Leptomycin B)	---	[1]

## Experimental Protocols

This section provides a detailed protocol for treating cultured cells with **Leptomycin A** and subsequently performing immunofluorescence staining to visualize the subcellular localization of a protein of interest.

Materials:

- **Leptomycin A** stock solution (in ethanol)
- Cell culture medium
- Phosphate-buffered saline (PBS)

- Fixation solution (e.g., 4% paraformaldehyde in PBS)
- Permeabilization solution (e.g., 0.1-0.5% Triton X-100 in PBS)
- Blocking solution (e.g., 1-5% BSA or 10% normal goat serum in PBS)
- Primary antibody against the protein of interest
- Fluorophore-conjugated secondary antibody
- Nuclear counterstain (e.g., DAPI)
- Antifade mounting medium
- Glass coverslips and microscope slides

#### Procedure:

- Cell Culture and Treatment:
  - Seed cells on sterile glass coverslips in a multi-well plate and culture until they reach the desired confluency.
  - Prepare the working concentration of **Leptomycin A** in pre-warmed cell culture medium. A typical starting concentration is in the low nanomolar range, but should be optimized for the specific cell line and protein of interest.
  - Remove the old medium from the cells and add the **Leptomycin A**-containing medium.
  - Incubate the cells for a predetermined time (e.g., 3-4 hours) at 37°C in a CO<sub>2</sub> incubator. A time-course experiment is recommended to determine the optimal incubation time.
- Fixation:
  - Carefully remove the medium and wash the cells twice with PBS.
  - Fix the cells by adding the fixation solution and incubating for 10-15 minutes at room temperature.

- Permeabilization:
  - Wash the cells three times with PBS for 5 minutes each.
  - Permeabilize the cells by adding the permeabilization solution and incubating for 10 minutes at room temperature. This step is necessary for antibodies to access intracellular antigens.
- Blocking:
  - Wash the cells three times with PBS for 5 minutes each.
  - Block non-specific antibody binding by incubating the cells in blocking solution for at least 1 hour at room temperature.
- Primary Antibody Incubation:
  - Dilute the primary antibody against the protein of interest in the blocking solution to its recommended working concentration.
  - Incubate the cells with the diluted primary antibody overnight at 4°C or for 1-2 hours at room temperature in a humidified chamber.
- Secondary Antibody Incubation:
  - Wash the cells three times with PBS for 5 minutes each.
  - Dilute the fluorophore-conjugated secondary antibody in the blocking solution. Protect the antibody from light.
  - Incubate the cells with the diluted secondary antibody for 1 hour at room temperature in the dark.
- Nuclear Counterstaining:
  - Wash the cells three times with PBS for 5 minutes each.

- Incubate the cells with a nuclear counterstain like DAPI for 5-10 minutes at room temperature in the dark.
- Mounting and Imaging:
  - Wash the cells two times with PBS.
  - Mount the coverslips onto microscope slides using an antifade mounting medium.
  - Seal the edges of the coverslip with nail polish.
  - Visualize the fluorescence signal using a fluorescence or confocal microscope.

## Visualizations

Diagram of the CRM1/XPO1-Mediated Nuclear Export Pathway and its Inhibition by **Leptomycin A**

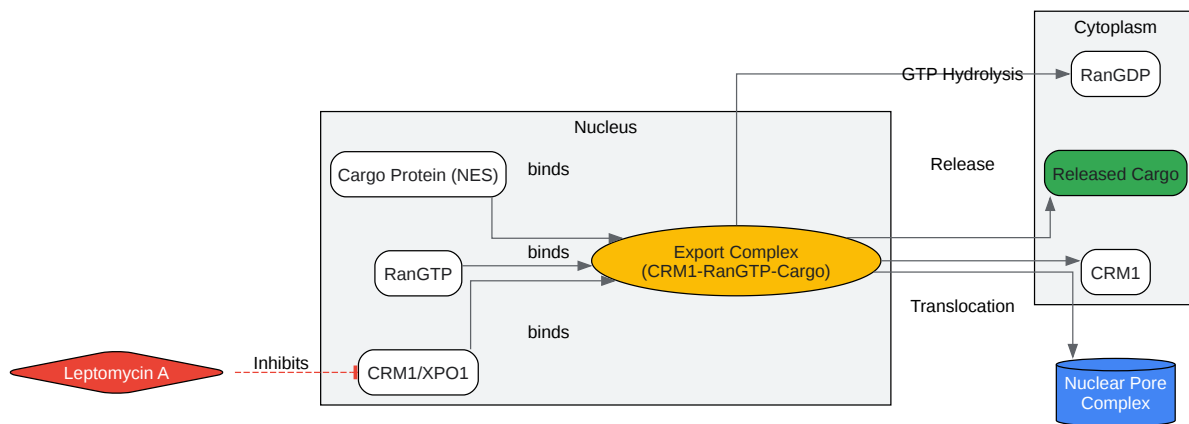

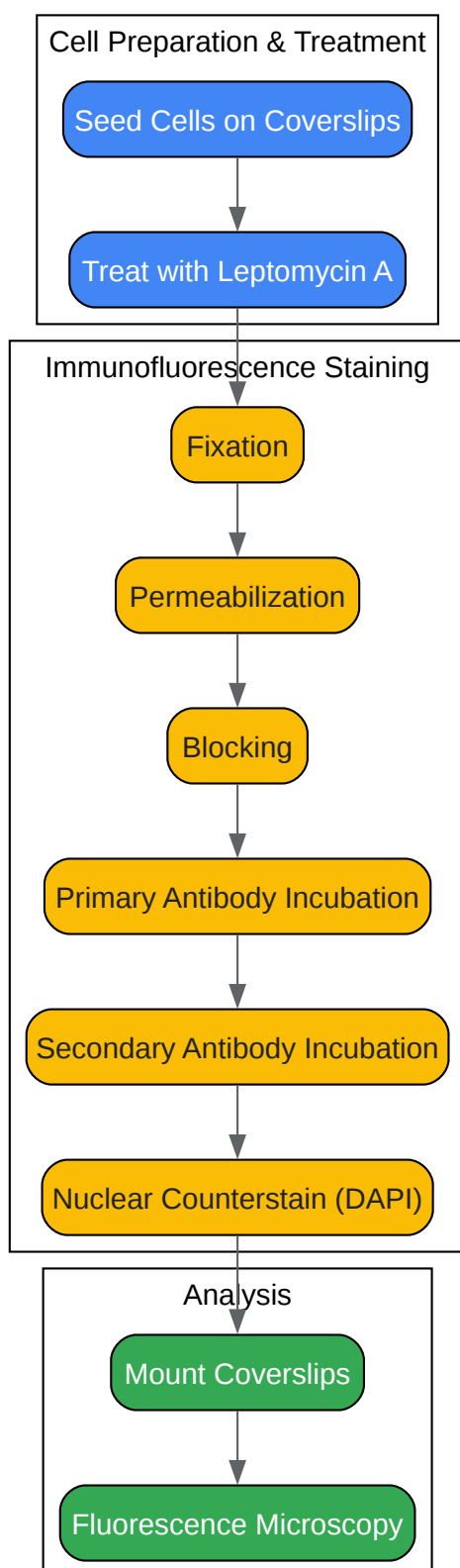

[Click to download full resolution via product page](#)

**Need Custom Synthesis?**

BenchChem offers custom synthesis for rare earth carbides and specific isotopic labeling.

Email: [info@benchchem.com](mailto:info@benchchem.com) or [Request Quote Online](#).

## References

- [1. Leptomycin B | Cell Signaling Technology \[cellsignal.com\]](#)
- [2. Leptomycin B inhibition of signal-mediated nuclear export by direct binding to CRM1 - PubMed \[pubmed.ncbi.nlm.nih.gov\]](#)
- [3. Leptomycin B Alters the Subcellular Distribution of CRM1 \(Exportin 1\) - PMC \[pmc.ncbi.nlm.nih.gov\]](#)
- [4. Leptomycin B inactivates CRM1/exportin 1 by covalent modification at a cysteine residue in the central conserved region - PMC \[pmc.ncbi.nlm.nih.gov\]](#)
- To cite this document: BenchChem. [Application Notes and Protocols for Leptomycin A Immunofluorescence Staining]. BenchChem, [2026]. [Online PDF]. Available at: [\[https://www.benchchem.com/product/b10776095/docs#application-notes-and-protocols-for-leptomycin-a-immunofluorescence-staining\]](https://www.benchchem.com/product/b10776095/docs#application-notes-and-protocols-for-leptomycin-a-immunofluorescence-staining)

---

**Disclaimer & Data Validity:**

The information provided in this document is for Research Use Only (RUO) and is strictly not intended for diagnostic or therapeutic procedures. While BenchChem strives to provide accurate protocols, we make no warranties, express or implied, regarding the fitness of this product for every specific experimental setup.

**Technical Support:** The protocols provided are for reference purposes. Unsure if this reagent suits your experiment?

**Need Industrial/Bulk Grade?** [Request Custom Synthesis Quote](#)

# BenchChem

Our mission is to be the trusted global source of essential and advanced chemicals, empowering scientists and researchers to drive progress in science and industry.

## Contact

Address: 3281 E Guasti Rd

Ontario, CA 91761, United States

Phone: (601) 213-4426

Email: [info@benchchem.com](mailto:info@benchchem.com)

[Contact our Ph.D. Support Team for a compatibility check](#)