

Application Notes: Metabolic Engineering for Enhanced Prephenic Acid Production

Author: BenchChem Technical Support Team. **Date:** April 2026

Compound of Interest

Compound Name: *Prephenic acid*

CAS No.: 87664-40-2

Cat. No.: B10776367

[Get Quote](#)

Introduction **Prephenic acid** (prephenate) is a crucial intermediate in the shikimate pathway, serving as the branch-point for the biosynthesis of the aromatic amino acids phenylalanine and tyrosine.[1][2] Beyond its role in primary metabolism, prephenate is a valuable precursor for a variety of natural products and specialty chemicals. However, its inherent instability and rapid conversion to downstream products make its accumulation in microbial hosts a significant challenge.[1] Metabolic engineering offers a powerful toolkit to rewire cellular metabolism, redirect carbon flux, and establish microbial cell factories for the high-yield production of **prephenic acid**.

This document outlines key metabolic engineering strategies, presents comparative data from engineered strains, and provides detailed protocols for the development and analysis of prephenate-producing microorganisms, primarily focusing on the model organism *Escherichia coli*.

Core Metabolic Engineering Strategies

The central strategy for overproducing **prephenic acid** involves a "push-and-pull" approach combined with pathway blockage. Carbon flux is "pushed" from central metabolism into the

shikimate pathway, "pulled" towards the synthesis of chorismate and its conversion to prephenate, and finally accumulated by "blocking" the downstream enzymatic conversions to phenylalanine and tyrosine.

- **Increasing Precursor Availability:** The shikimate pathway begins with the condensation of phosphoenolpyruvate (PEP) and erythrose-4-phosphate (E4P).[3][4] Enhancing the intracellular pools of these precursors is a foundational step.
 - **PEP Enhancement:** Inactivating the phosphoenolpyruvate:carbohydrate phosphotransferase system (PTS), which consumes PEP during glucose uptake, is a common strategy.[5] Deleting genes like *ptsH*, *ptsI*, and *crr* can significantly increase PEP availability.[6] Additionally, overexpressing PEP synthase (*ppsA*) can replenish PEP from pyruvate.
 - **E4P Enhancement:** Overexpressing transketolase (*tktA*) from the pentose phosphate pathway increases the supply of E4P.[5]
- **Alleviating Feedback Inhibition:** The shikimate pathway is tightly regulated by feedback inhibition from the final products (phenylalanine, tyrosine, and tryptophan).[3][4]
 - **DAHP Synthase:** The first committed step is catalyzed by 3-deoxy-D-arabino-heptulosonate-7-phosphate (DAHP) synthase, encoded by *aroF*, *aroG*, and *aroH* in *E. coli*. These isoenzymes are inhibited by tyrosine, phenylalanine, and tryptophan, respectively. Expressing feedback-resistant (*fbr*) variants, such as *aroG fbr*, is critical to channel carbon into the pathway.[6][7]
- **Enhancing the Shikimate Pathway Flux:** To prevent the accumulation of intermediate metabolites and pull flux towards prephenate, key enzymes in the pathway are often overexpressed. This includes shikimate dehydrogenase (*aroE*) and shikimate kinase (*aroK*, *aroL*).[5][6]
- **Blocking Downstream Pathways:** This is the most crucial step for prephenate accumulation. The enzymes that consume prephenate must be inactivated.
 - In *E. coli*, chorismate mutase/prephenate dehydratase (*pheA*) and chorismate mutase/prephenate dehydrogenase (*tyrA*) are bifunctional enzymes that both produce and consume prephenate.[8][9]

- Knocking out both pheA and tyrA genes eliminates the primary routes of prephenate consumption.[\[10\]](#)[\[11\]](#)
- Optimizing Prephenate Synthesis: With the consuming pathways blocked, the conversion of chorismate to prephenate must be efficiently catalyzed. Since the native chorismate mutase domains are part of the now-deleted pheA and tyrA genes, a monofunctional chorismate mutase must be introduced. An effective choice is the chorismate mutase domain from E. coli (pheA* or CM-domain) or a heterologous feedback-resistant chorismate mutase.

Visualizing Metabolic Engineering Strategies

Shikimate Pathway and Engineering Targets

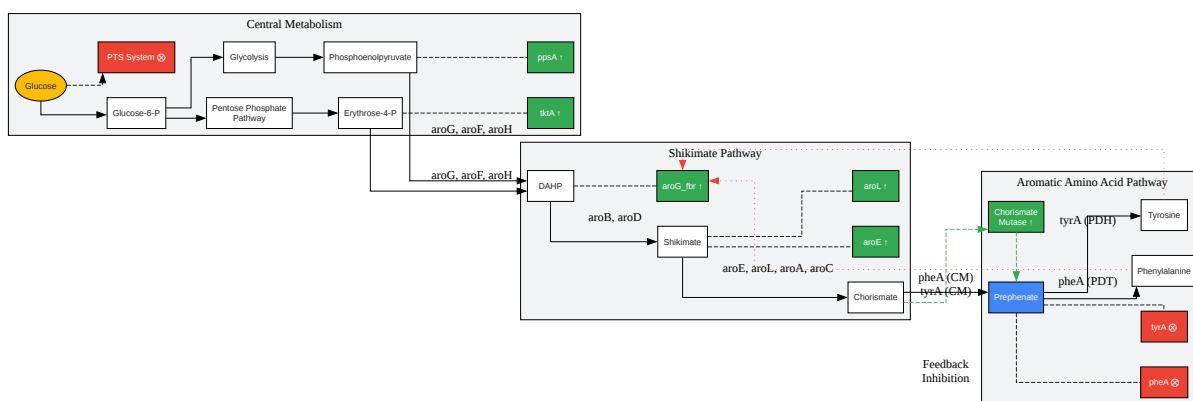

[Click to download full resolution via product page](#)

Caption: Metabolic engineering strategy for prephenate production in *E. coli*.

Data Presentation

While data for strains engineered exclusively for **prephenic acid** accumulation is limited due to its instability, analysis of strains developed for phenylalanine and tyrosine provides valuable insights into the flux capacity of the shikimate pathway. High titers of these downstream products indicate a high rate of prephenate synthesis.

Table 1: Performance of Engineered E. coli Strains for Aromatic Compound Production

Strain Description	Product	Titer (g/L)	Yield (g/g glucose)	Productivity (g/L/h)	Reference(s)
Overexpression of tktA, ppsA, feedback-resistant aroG and trpE.	Tryptophan	40.2	~0.15	~0.84	[6]
Overexpression of feedback-resistant aroG and pheA.	L-Phenylalanine	0.33	0.33	N/A	[12]
Overexpression of marA in an evolved strain with heterologous aroK1, aroL1, pheA1 and native aroA, aroC, tyrB.	L-Phenylalanine	80.48	0.27	1.68	[13]
Deletion of pheA, tyrA, tyrB, aspC, tyrR. Overexpression of aroFBL and a heterologous p-aminophenyl	p-Aminophenyl ethanol	2.5	0.11 (C-mol/C-mol)	~0.05	[10]

ethanol
pathway.

Deletion of
pheA, tyrA,
tyrB, aspC,
tyrR.

Overexpressi
on of aroFBL
and a
heterologous

p-
Aminophenyl
acetic acid

3.4

0.17 (C-
mol/C-mol)

~0.07

[10]

p-
aminophenyl
acetic acid
pathway.

Overexpressi
on of
feedback-
resistant tyrA
and a
heterologous
cyclohexadie
nyl
dehydrogena
se (tyrC).

L-Tyrosine

9.7

0.10

0.073

[8]

Note: N/A indicates data not available. These values demonstrate the high metabolic flux achievable through the shikimate pathway to prephenate, which can be harnessed for its accumulation by blocking downstream enzymes.

Experimental Protocols

Protocol 1: Construction of a Prephenate-Producing E. coli Strain

This protocol outlines the genetic modification of E. coli K-12 MG1655 to create a base strain for prephenate production using lambda red recombineering for gene knockouts.

1. Materials

- E. coli K-12 MG1655
- Plasmids: pKD46 (lambda red recombinase), pKD4 (FRT-kan-FRT template), pCP20 (FLP recombinase)
- Primers for pheA and tyrA knockout (with homology arms)
- LB medium, SOC medium, Agar plates with appropriate antibiotics (Ampicillin, Kanamycin, Chloramphenicol)
- L-arabinose, Isopropyl β -D-1-thiogalactopyranoside (IPTG)
- Plasmid pTrc99a (or similar) carrying feedback-resistant aroG fbr and a monofunctional chorismate mutase.

2. Procedure: Gene Knockout (e.g., pheA)

- Prepare Electrocompetent Cells: Grow E. coli MG1655 carrying pKD46 at 30°C in LB medium with ampicillin and 10 mM L-arabinose to an OD600 of ~0.6. Prepare electrocompetent cells by washing with ice-cold sterile 10% glycerol.
- Prepare Deletion Cassette: Amplify the kanamycin resistance cassette from pKD4 using primers with 50-bp homology arms flanking the pheA gene. Purify the PCR product.
- Electroporation: Electroporate ~100 ng of the purified PCR product into the competent cells. Immediately add 1 mL of SOC medium and incubate at 37°C for 1-2 hours.
- Selection: Plate the culture on LB agar plates containing kanamycin to select for successful recombinants.
- Verification: Verify the knockout by colony PCR using primers flanking the pheA locus.
- Curing Kanamycin Resistance: Transform the verified knockout strain with pCP20. Grow at 30°C on ampicillin plates. Then, streak colonies on non-selective plates and incubate at 42°C to induce FLP recombinase and cure the pCP20 plasmid. Screen for colonies that are sensitive to both kanamycin and ampicillin.

- Sequential Knockout: Repeat steps 1-6 for the *tyrA* gene to create the double knockout strain (MG1655 Δ pheA Δ tyrA). This strain is now an aromatic amino acid auxotroph.

3. Procedure: Pathway Expression

- Transform the final double knockout strain with an expression plasmid (e.g., pTrc-aroG fbr-CM) containing a feedback-resistant DAHP synthase and a monofunctional chorismate mutase under an inducible promoter.
- Select transformants on LB agar plates containing the appropriate antibiotic (e.g., ampicillin) and supplemented with L-phenylalanine and L-tyrosine (e.g., 40 mg/L each) to support growth.

General Experimental Workflow

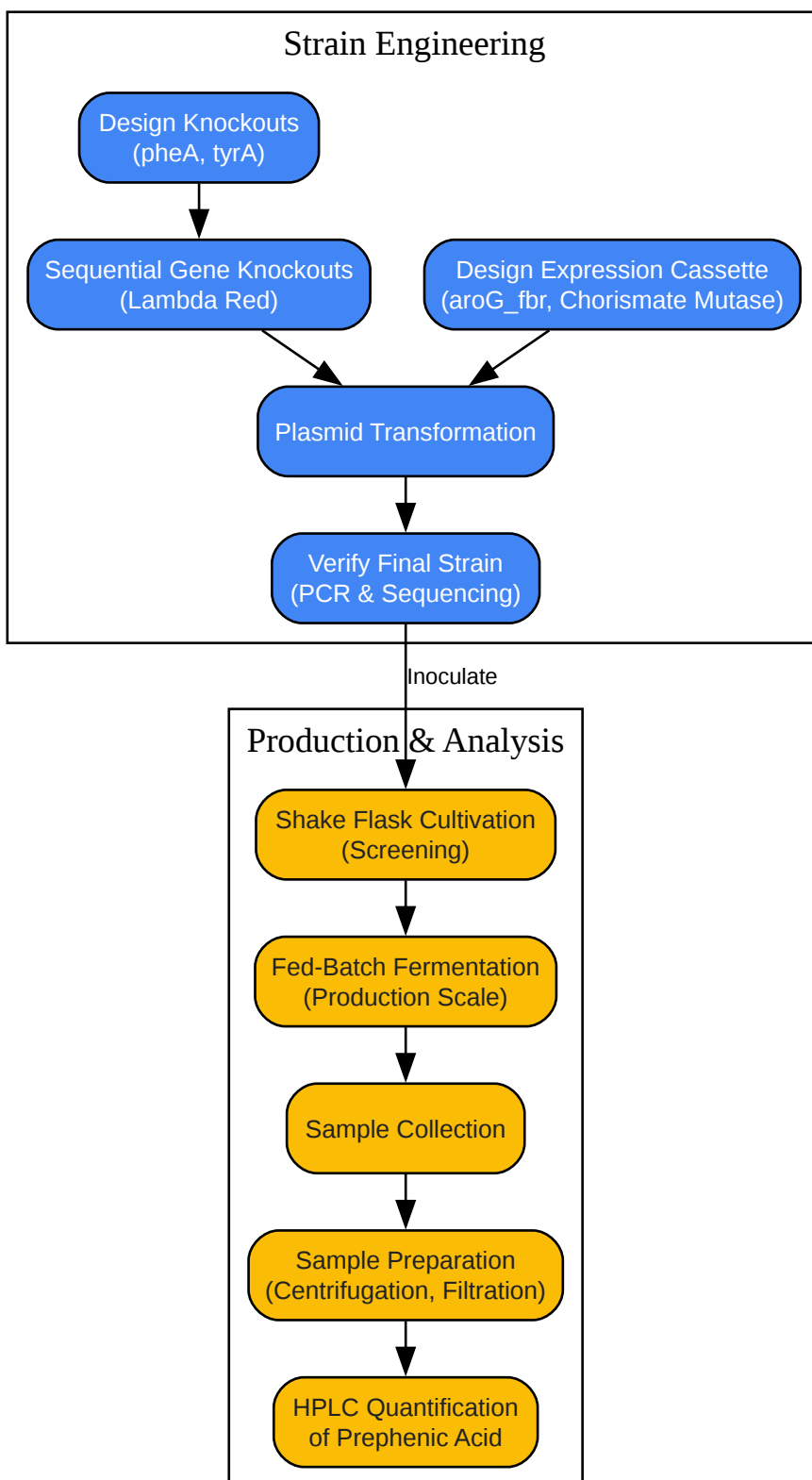

[Click to download full resolution via product page](#)

Caption: General workflow for prephenate production strain development.

Protocol 2: Fed-Batch Fermentation for Prephenate Production

1. Media and Conditions

- Seed Culture: M9 minimal medium supplemented with 20 g/L glucose, 40 mg/L L-phenylalanine, and 40 mg/L L-tyrosine.
- Fermenter Medium: Defined mineral medium with an initial 20 g/L glucose, trace elements, and required antibiotics.
- Feed Solution: Concentrated glucose solution (e.g., 500 g/L).
- Conditions: Temperature 37°C, pH controlled at 7.0 (with NH₄OH), dissolved oxygen (DO) maintained at >20% saturation by adjusting agitation and aeration.

2. Procedure

- Inoculum: Grow a seed culture overnight in supplemented M9 medium at 37°C.
- Fermentation Start: Inoculate the fermenter with the seed culture to a starting OD₆₀₀ of ~0.1.
- Batch Phase: Allow the culture to grow until the initial glucose is depleted, identified by a sharp increase in DO.
- Induction: When the OD₆₀₀ reaches ~10-15, add IPTG to a final concentration of 0.1-1.0 mM to induce expression of the pathway genes.
- Fed-Batch Phase: Start the glucose feed to maintain a low glucose concentration in the fermenter. A DO-stat or pH-stat feeding strategy can be employed.
- Sampling: Collect samples periodically to measure OD₆₀₀, residual glucose, and prephenate concentration.

Protocol 3: Quantification of Prephenic Acid by HPLC

Prephenic acid is unstable and readily converts to phenylpyruvic acid under acidic conditions.

[1] This protocol uses this conversion for stable quantification.

1. Materials

- High-Performance Liquid Chromatography (HPLC) system with a UV detector.
- Reversed-phase C18 column (e.g., 4.6 x 250 mm, 5 μ m).
- Mobile Phase: Acetonitrile and water with 0.1% trifluoroacetic acid (TFA) or phosphoric acid.
- Phenylpyruvic acid standard.
- Hydrochloric acid (HCl).

2. Sample Preparation

- Collect 1 mL of fermentation broth.
- Centrifuge at 13,000 x g for 5 minutes to pellet the cells.
- Transfer the supernatant to a new microfuge tube.
- Acid Conversion: Add 100 μ L of 1 M HCl to 900 μ L of the supernatant. Incubate at 30°C for 15 minutes to quantitatively convert prephenate to phenylpyruvic acid.
- Filter the acidified sample through a 0.22 μ m syringe filter into an HPLC vial.

3. HPLC Method

- Column: C18 reversed-phase column.
- Mobile Phase: Isocratic or gradient elution. A typical starting point is 30:70 (v/v) acetonitrile:water with 0.1% TFA.
- Flow Rate: 1.0 mL/min.
- Detection: UV at 210 nm or 280 nm.

- Quantification: Create a standard curve using known concentrations of phenylpyruvic acid. Calculate the concentration in the sample based on the peak area, which corresponds to the initial prephenate concentration.

Note: For direct quantification of unstable prephenate, specialized ion-exchange or hydrophilic interaction liquid chromatography (HILIC) methods at neutral pH would be required, but the acid conversion method is often more robust for routine analysis.[14][15]

Need Custom Synthesis?

BenchChem offers custom synthesis for rare earth carbides and specific isotopic labeling.

Email: info@benchchem.com or [Request Quote Online](#).

References

- [1. Prephenic acid - Wikipedia \[en.wikipedia.org\]](#)
- [2. alchetron.com \[alchetron.com\]](#)
- [3. THE SHIKIMATE PATHWAY - PubMed \[pubmed.ncbi.nlm.nih.gov\]](#)
- [4. The shikimate pathway: gateway to metabolic diversity - PMC \[pmc.ncbi.nlm.nih.gov\]](#)
- [5. Metabolic Engineering of Shikimic Acid Biosynthesis Pathway for the Production of Shikimic Acid and Its Branched Products in Microorganisms: Advances and Prospects - PMC \[pmc.ncbi.nlm.nih.gov\]](#)
- [6. Frontiers | Metabolic Engineering of the Shikimate Pathway for Production of Aromatics and Derived Compounds—Present and Future Strain Construction Strategies \[frontiersin.org\]](#)
- [7. Systems metabolic engineering strategies for the production of amino acids - PMC \[pmc.ncbi.nlm.nih.gov\]](#)
- [8. journals.asm.org \[journals.asm.org\]](#)
- [9. THE BIOSYNTHESIS OF PHENYLALANINE AND TYROSINE; ENZYMES CONVERTING CHORISMIC ACID INTO PREPHENIC ACID AND THEIR RELATIONSHIPS TO PREPHENATE DEHYDRATASE AND PREPHENATE DEHYDROGENASE - PubMed \[pubmed.ncbi.nlm.nih.gov\]](#)
- [10. Metabolic Engineering of Escherichia coli for para-Amino-Phenylethanol and para-Amino-Phenylacetic Acid Biosynthesis - PMC \[pmc.ncbi.nlm.nih.gov\]](#)

- [11. Metabolic Engineering of the Shikimate Pathway for Production of Aromatics and Derived Compounds—Present and Future Strain Construction Strategies - PMC](#) [pubmed.ncbi.nlm.nih.gov]
- [12. researchgate.net](#) [researchgate.net]
- [13. Metabolic Engineering of Escherichia coli for High-Level Production of L-Phenylalanine - PubMed](#) [pubmed.ncbi.nlm.nih.gov]
- [14. Purification of chorismate, prephenate, and arogenate by HPLC - PubMed](#) [pubmed.ncbi.nlm.nih.gov]
- [15. researchgate.net](#) [researchgate.net]
- To cite this document: BenchChem. [Application Notes: Metabolic Engineering for Enhanced Prephenic Acid Production]. BenchChem, [2026]. [Online PDF]. Available at: [<https://www.benchchem.com/product/b10776367/docs#application-notes-metabolic-engineering-for-enhanced-prephenic-acid-production>]

Disclaimer & Data Validity:

The information provided in this document is for Research Use Only (RUO) and is strictly not intended for diagnostic or therapeutic procedures. While BenchChem strives to provide accurate protocols, we make no warranties, express or implied, regarding the fitness of this product for every specific experimental setup.

Technical Support: The protocols provided are for reference purposes. Unsure if this reagent suits your experiment?

Need Industrial/Bulk Grade? [Request Custom Synthesis Quote](#)

BenchChem

Our mission is to be the trusted global source of essential and advanced chemicals, empowering scientists and researchers to drive progress in science and industry.

Contact

Address: 3281 E Guasti Rd
Ontario, CA 91761, United States
Phone: (601) 213-4426
Email: info@benchchem.com

Contact our Ph.D. Support Team for a compatibility check