

improving AM-6538 stability in solution

Author: BenchChem Technical Support Team. **Date:** April 2026

Compound of Interest

Compound Name: AM-6538
Cat. No.: B10775092

[Get Quote](#)

Technical Support Center: AM-6538

This technical support center provides researchers, scientists, and drug development professionals with guidance on the use and stability of **AM-6538**, a high-affinity, pseudo-irreversible antagonist of the Cannabinoid Receptor 1 (CB1).

Frequently Asked Questions (FAQs)

Q1: What is **AM-6538** and what is its primary mechanism of action?

A1: **AM-6538** is a potent and selective antagonist of the Cannabinoid Receptor 1 (CB1). It is a structural analog of rimonabant and is characterized by its high affinity and wash-resistant binding to the CB1 receptor, leading to a long-lasting, pseudo-irreversible antagonism.^{[1][2]} This property makes it a valuable tool for studying the CB1 receptor and its downstream signaling pathways.

Q2: What are the common research applications of **AM-6538**?

A2: **AM-6538** is primarily used in preclinical research to investigate the role of the endocannabinoid system in various physiological and pathological processes. Its long-acting antagonist effects are particularly useful for in vivo studies aiming to understand the

consequences of prolonged CB1 receptor blockade.[1][2] It has been instrumental in stabilizing the CB1 receptor for crystallographic studies, providing insights into its structure.

Q3: How should I prepare a solution of **AM-6538** for in vivo experiments?

A3: A common method for preparing a suspended solution of **AM-6538** for oral or intraperitoneal injection involves the use of a vehicle containing Dimethyl Sulfoxide (DMSO), Polyethylene Glycol 300 (PEG300), Tween-80, and saline. A published protocol suggests first dissolving **AM-6538** in DMSO, then mixing with PEG300 and Tween-80, and finally adding saline to the desired volume.[1] For detailed proportions, please refer to the specific protocol from your supplier or relevant publications.

Q4: What is the known signaling pathway that **AM-6538** antagonizes?

A4: **AM-6538**, as a CB1 receptor antagonist, blocks the signaling cascade initiated by the activation of the CB1 receptor by endocannabinoids (like anandamide and 2-AG) or exogenous agonists. The CB1 receptor is a G-protein coupled receptor (GPCR) that primarily couples to the inhibitory G-protein, Gi/o. Activation of CB1 typically leads to the inhibition of adenylyl cyclase, resulting in decreased cyclic AMP (cAMP) levels, and modulation of ion channels (e.g., inhibition of Ca²⁺ channels and activation of K⁺ channels). By blocking the CB1 receptor, **AM-6538** prevents these downstream effects.

Troubleshooting Guide

Issue	Possible Cause	Recommendation
Precipitation of AM-6538 in aqueous solution.	AM-6538 has low aqueous solubility. The proportion of aqueous buffer to organic solvent may be too high.	Increase the percentage of organic solvent (e.g., DMSO, ethanol) in your final solution. Prepare solutions fresh before each experiment. Consider using a vehicle containing solubilizing agents like PEG300 and Tween-80 for in vivo studies.[1]
Inconsistent or weaker than expected antagonist activity.	Degradation of AM-6538 in solution due to improper storage or handling. Inaccurate concentration of the stock solution.	Store stock solutions at -20°C or -80°C in a tightly sealed, light-protected vial. Prepare fresh working solutions for each experiment. Re-evaluate the concentration of your stock solution. For general guidance, cannabinoids can be susceptible to degradation by light, heat, and oxidation.
Difficulty dissolving AM-6538 powder.	Use of an inappropriate solvent. Insufficient vortexing or sonication.	AM-6538 is generally soluble in organic solvents such as DMSO and ethanol. Ensure the powder is fully dissolved in the organic solvent before adding any aqueous components. Gentle warming and sonication may aid dissolution, but prolonged exposure to heat should be avoided to prevent degradation.
Variability in experimental results between batches of AM-6538 solution.	Inconsistent solution preparation. Degradation of the stock solution over time.	Standardize your solution preparation protocol. Aliquot stock solutions into smaller

volumes to avoid repeated freeze-thaw cycles. If a stock solution has been stored for an extended period, consider preparing a fresh stock.

Experimental Protocols

Protocol 1: Preparation of a Suspended **AM-6538** Solution for In Vivo Studies

This protocol is adapted from publicly available information for the preparation of a suspended solution suitable for oral or intraperitoneal administration in animal models.[\[1\]](#)

Materials:

- **AM-6538** powder
- Dimethyl Sulfoxide (DMSO)
- Polyethylene Glycol 300 (PEG300)
- Tween-80
- Saline (0.9% NaCl)
- Sterile microcentrifuge tubes
- Vortex mixer

Procedure:

- Prepare a stock solution of **AM-6538** in DMSO. For example, to achieve a final concentration of 4.5 mg/mL in the suspended solution, a 45 mg/mL stock in DMSO can be prepared.
- In a sterile microcentrifuge tube, add the required volume of the **AM-6538**/DMSO stock solution.

- Add PEG300 to the tube. A suggested ratio is 1 part DMSO stock to 4 parts PEG300. Vortex until the solution is homogeneous.
- Add Tween-80 to the mixture. A suggested ratio is 0.5 parts Tween-80 to the initial volume of the DMSO stock. Vortex thoroughly.
- Slowly add saline to the mixture while vortexing to reach the final desired volume. A suggested ratio is 4.5 parts saline to the initial volume of the DMSO stock.
- The final solution will be a suspension. Ensure it is well-mixed before each administration.

Quantitative Data Summary: **AM-6538** Solution Components

Component	Example Volume Ratio	Purpose
AM-6538/DMSO Stock	1 part	Active compound and primary solvent
PEG300	4 parts	Solubilizing agent and vehicle
Tween-80	0.5 parts	Surfactant to aid in suspension
Saline	4.5 parts	Diluent and vehicle

Note: Specific stability studies for **AM-6538** in this vehicle are not publicly available. It is recommended to prepare this suspension fresh for each experiment.

Visualizations

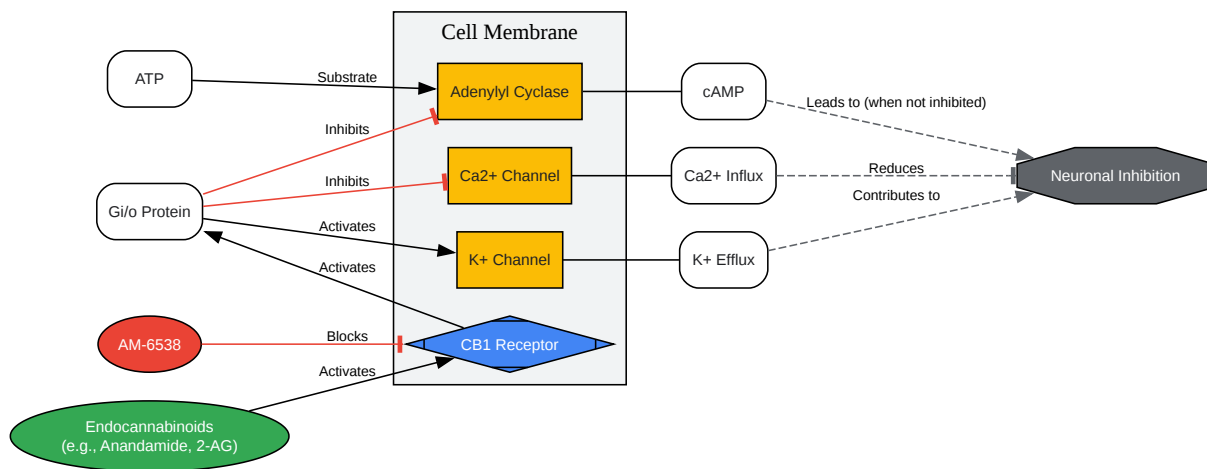

[Click to download full resolution via product page](#)

Caption: Antagonistic action of **AM-6538** on the CB1 receptor signaling pathway.

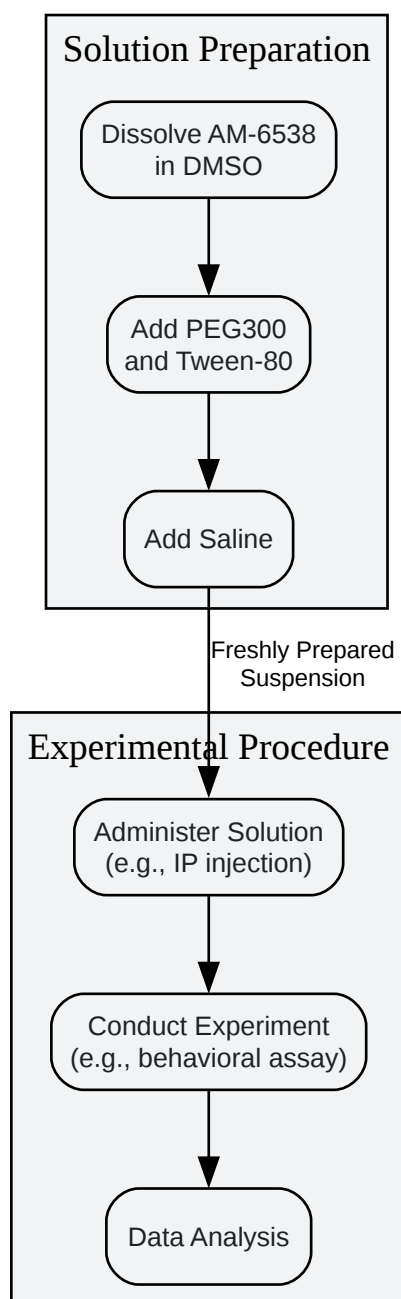

[Click to download full resolution via product page](#)

Caption: General experimental workflow for in vivo studies using **AM-6538**.

Need Custom Synthesis?

BenchChem offers custom synthesis for rare earth carbides and specific isotopic labeling.

Email: info@benchchem.com or [Request Quote Online](#).

References

- [1. medchemexpress.com \[medchemexpress.com\]](https://www.medchemexpress.com)
- [2. Long-Lasting In Vivo Effects of the Cannabinoid CB1 Antagonist AM6538 - PMC \[pmc.ncbi.nlm.nih.gov\]](https://pubmed.ncbi.nlm.nih.gov/2026/01/01/long-lasting-in-vivo-effects-of-the-cannabinoid-cb1-antagonist-am6538/)
- To cite this document: BenchChem. [improving AM-6538 stability in solution]. BenchChem, [2026]. [Online PDF]. Available at: [\[https://www.benchchem.com/product/b10775092/docs#improving-am-6538-stability-in-solution\]](https://www.benchchem.com/product/b10775092/docs#improving-am-6538-stability-in-solution)

Disclaimer & Data Validity:

The information provided in this document is for Research Use Only (RUO) and is strictly not intended for diagnostic or therapeutic procedures. While BenchChem strives to provide accurate protocols, we make no warranties, express or implied, regarding the fitness of this product for every specific experimental setup.

Technical Support: The protocols provided are for reference purposes. Unsure if this reagent suits your experiment?

Need Industrial/Bulk Grade? [Request Custom Synthesis Quote](#)

BenchChem

Our mission is to be the trusted global source of essential and advanced chemicals, empowering scientists and researchers to drive progress in science and industry.

Contact

Address: 3281 E Guasti Rd
Ontario, CA 91761, United States
Phone: (601) 213-4426
Email: info@benchchem.com

Contact our Ph.D. Support Team for a compatibility check