

Technical Support Center: Addressing Variability in NS13001 Dose-Response Curves

Author: BenchChem Technical Support Team. **Date:** April 2026

Compound of Interest

Compound Name: NS13001
Cat. No.: B10775244

[Get Quote](#)

This technical support center provides troubleshooting guidance and frequently asked questions (FAQs) for researchers, scientists, and drug development professionals encountering variability in dose-response curves when working with **NS13001**, a selective positive modulator of SK2 and SK3 potassium channels.

Frequently Asked Questions (FAQs)

Q1: What is **NS13001** and what is its primary mechanism of action?

NS13001 is a novel, potent, and selective positive allosteric modulator of the small-conductance calcium-activated potassium (KCa) channels SK2 (KCa2.2) and SK3 (KCa2.3).[1][2] It shows significantly lower activity towards SK1 (KCa2.1) channels.[1] **NS13001** acts by increasing the apparent Ca²⁺ sensitivity of SK2 and SK3 channels, leading to their activation at lower intracellular calcium concentrations.[1][3] This results in membrane hyperpolarization and a reduction in neuronal excitability.[4]

Q2: What are the typical EC₅₀ values for **NS13001**?

The half-maximal effective concentration (EC₅₀) of **NS13001** is dependent on the specific SK channel subtype and the intracellular Ca²⁺ concentration. In human embryonic kidney

(HEK293) cells expressing specific human SK channel subtypes, the following EC50 values have been reported at a free Ca²⁺ concentration of 0.2 μM:

Channel Subtype	EC50 (μM)	Hill Coefficient (nH)
hSK3	0.14	1.0
hSK2	1.8	1.4
hSK1	> 100	-

Data sourced from Kasumu et al. (2012)[1]

It is important to note that these values were determined in a specific in vitro system and may vary depending on the cell type, experimental conditions, and assay readout.[5][6]

Q3: Why am I observing significant variability in my **NS13001** dose-response curves between experiments?

Variability in dose-response curves is a common issue in pharmacological studies and can arise from several factors.[5][7][8] These can be broadly categorized as issues related to the compound itself, the biological system, or the experimental procedure. Specific potential causes are addressed in the troubleshooting section below.

Q4: Can **NS13001** affect cell viability?

As a modulator of ion channels involved in regulating neuronal excitability, high concentrations or prolonged exposure to **NS13001** could potentially impact cell viability, although it is generally considered to have a good therapeutic window. It is recommended to perform a cell viability assay (e.g., MTT, CCK-8, or WST-1) to determine the cytotoxic concentration range of **NS13001** in your specific cell model.[9][10][11][12]

Troubleshooting Guide

Problem 1: High Variability Between Replicates

Question: My replicate wells/dishes for the same **NS13001** concentration show vastly different responses. What could be the cause?

Answer: High variability between replicates often points to technical inconsistencies in your experimental setup.[\[5\]](#)[\[7\]](#)

Potential Cause	Recommended Solution
Inaccurate Pipetting	Calibrate pipettes regularly. For viscous solutions, consider using reverse pipetting techniques. Ensure consistent and accurate liquid handling for all steps.
Inconsistent Cell Seeding	Ensure a homogenous single-cell suspension before plating. Use a cell counter for accurate cell density. Avoid "edge effects" by not using the outer wells of a microplate or by filling them with a buffer. [5]
Incomplete Reagent Mixing	Gently mix the plate after adding NS13001 and other reagents by tapping or using a plate shaker.
Compound Precipitation	Visually inspect your NS13001 dilutions for any signs of precipitation, especially at higher concentrations. Ensure the solvent concentration (e.g., DMSO) is consistent and non-toxic across all wells.

Problem 2: Inconsistent EC50/IC50 Values Across Experiments

Question: The EC50/IC50 value for **NS13001** is significantly different from my previous experiments or from published values. What should I check?

Answer: A shift in the EC50/IC50 value suggests a change in one or more key experimental parameters.[\[5\]](#)[\[6\]](#)[\[13\]](#)[\[14\]](#)

Potential Cause	Recommended Solution
Cell Health and Passage Number	Use cells that are in the logarithmic growth phase and within a consistent, narrow passage number range for all experiments.[5] Changes in cell health can alter the expression and function of SK channels.
Variations in Media and Supplements	New lots of serum or media can have different compositions that may affect cell growth and drug response. Test new lots before use in critical experiments.[7]
Inconsistent Incubation Times	The duration of NS13001 exposure can influence the observed effect. Maintain precise and consistent incubation times for all experiments.[6]
NS13001 Stock and Dilution Errors	Verify the concentration of your stock solution. Prepare fresh serial dilutions for each experiment to avoid degradation. Protect stock solutions from light and repeated freeze-thaw cycles.[7]
Assay Readout Timing	For kinetic assays, ensure that the measurement is taken at a consistent time point and within the linear range of the assay.
Intracellular Calcium Concentration	Since NS13001's potency is dependent on intracellular calcium levels, any experimental manipulations that alter calcium homeostasis will affect the dose-response curve.[1]

Problem 3: Atypical Dose-Response Curve Shape

Question: My dose-response curve for **NS13001** is not a standard sigmoidal shape (e.g., it's too steep, too shallow, or biphasic). What could be the reason?

Answer: The shape of the dose-response curve provides insights into the mechanism of action and potential experimental artifacts.[15]

Potential Cause	Recommended Solution
Shallow Curve	This may indicate positive cooperativity in binding or could be an artifact of compound instability or solubility issues at higher concentrations.[5] It could also suggest complex biological responses.
Steep Curve	A steep curve might suggest positive cooperativity or an artifact within a specific concentration range. Ensure your dose range is wide enough to capture the full curve.[5]
Biphasic Curve	This could indicate off-target effects at higher concentrations or complex, multi-target interactions. Consider using a more specific assay or investigating potential off-target activities of NS13001.
Inappropriate Curve Fitting Model	Ensure you are using an appropriate non-linear regression model (e.g., four-parameter logistic equation) to fit your data.[14]

Experimental Protocols

Cell Viability Assay (MTT/WST-1)

This protocol is a general guideline for assessing the cytotoxicity of **NS13001**.

- **Cell Seeding:** Plate cells in a 96-well plate at a predetermined optimal density and allow them to adhere overnight.[9]
- **Compound Preparation:** Prepare a 2X serial dilution of **NS13001** in culture medium. A starting concentration range of 0.01 μM to 100 μM is recommended. Include a vehicle control (e.g., DMSO) at the same final concentration as in the drug-treated wells.
- **Cell Treatment:** Remove the old medium and add 100 μL of the prepared **NS13001** dilutions or vehicle control to the respective wells.

- Incubation: Incubate the plate for the desired duration (e.g., 24, 48, or 72 hours) at 37°C in a 5% CO₂ incubator.
- MTT/WST-1 Addition:
 - MTT: Add 10 µL of 5 mg/mL MTT solution to each well and incubate for 3-4 hours. Then, add 100 µL of solubilization solution and incubate overnight.[9][10]
 - WST-1: Add 10 µL of WST-1 reagent to each well and incubate for 1-4 hours.[12]
- Data Acquisition: Measure the absorbance at the appropriate wavelength (e.g., 570 nm for MTT, 450 nm for WST-1) using a microplate reader.
- Data Analysis: Normalize the data to the vehicle control and plot the percentage of cell viability against the logarithm of the **NS13001** concentration. Fit the data to a sigmoidal dose-response curve to determine the IC₅₀ value.[6]

Whole-Cell Patch-Clamp Electrophysiology

This protocol provides a general workflow for measuring the effect of **NS13001** on SK channel currents.

- Cell Preparation: Use cells endogenously expressing or transiently transfected with SK2 or SK3 channels. Plate cells on coverslips suitable for patch-clamp recording.
- Solution Preparation:
 - External Solution (in mM): 140 NaCl, 5 KCl, 2 CaCl₂, 1 MgCl₂, 10 HEPES, 10 Glucose (pH 7.4 with NaOH).
 - Internal (Pipette) Solution (in mM): 140 KCl, 1 MgCl₂, 10 HEPES, 5 EGTA, and a buffered Ca²⁺ solution to achieve the desired free Ca²⁺ concentration (e.g., 0.2 µM).[1] Include 2 mM ATP-Mg and 0.3 mM GTP to maintain channel function.[16]
- Recording Setup:
 - Pull borosilicate glass pipettes to a resistance of 3-5 MΩ when filled with the internal solution.

- Establish a Giga-ohm seal and obtain a whole-cell configuration.[17][18]
- Hold the cell at a membrane potential of -80 mV.
- Data Acquisition:
 - Record baseline SK channel currents using a suitable voltage protocol (e.g., voltage ramps or steps).
 - Perfuse the cell with the external solution containing various concentrations of **NS13001**.
 - Record the potentiation of the SK current at each concentration.
 - Perform a washout with the control external solution to check for reversibility.
- Data Analysis: Measure the peak current amplitude at each **NS13001** concentration. Normalize the current to the baseline and plot the normalized current against the logarithm of the **NS13001** concentration. Fit the data to a sigmoidal dose-response curve to determine the EC50 value.

Visualizations

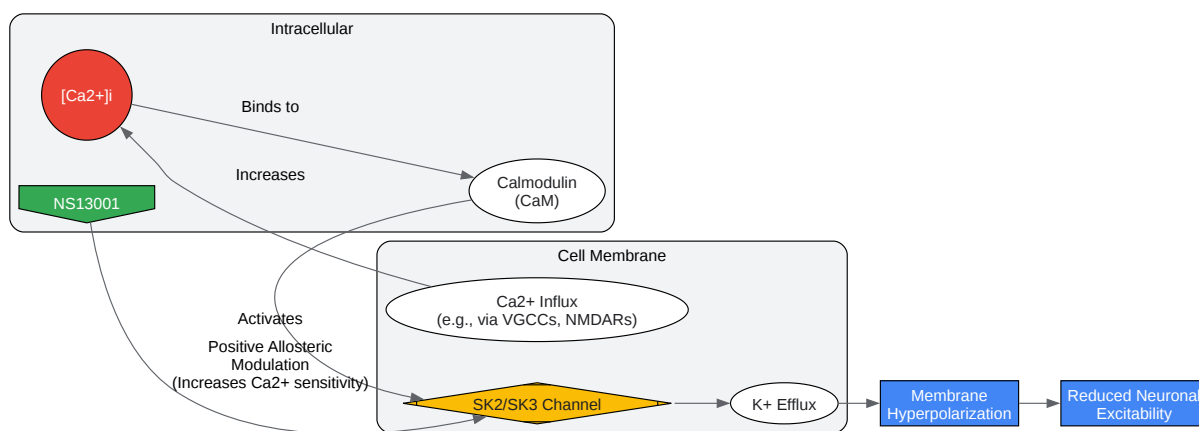

[Click to download full resolution via product page](#)

Caption: Signaling pathway of **NS13001** action on SK2/SK3 channels.

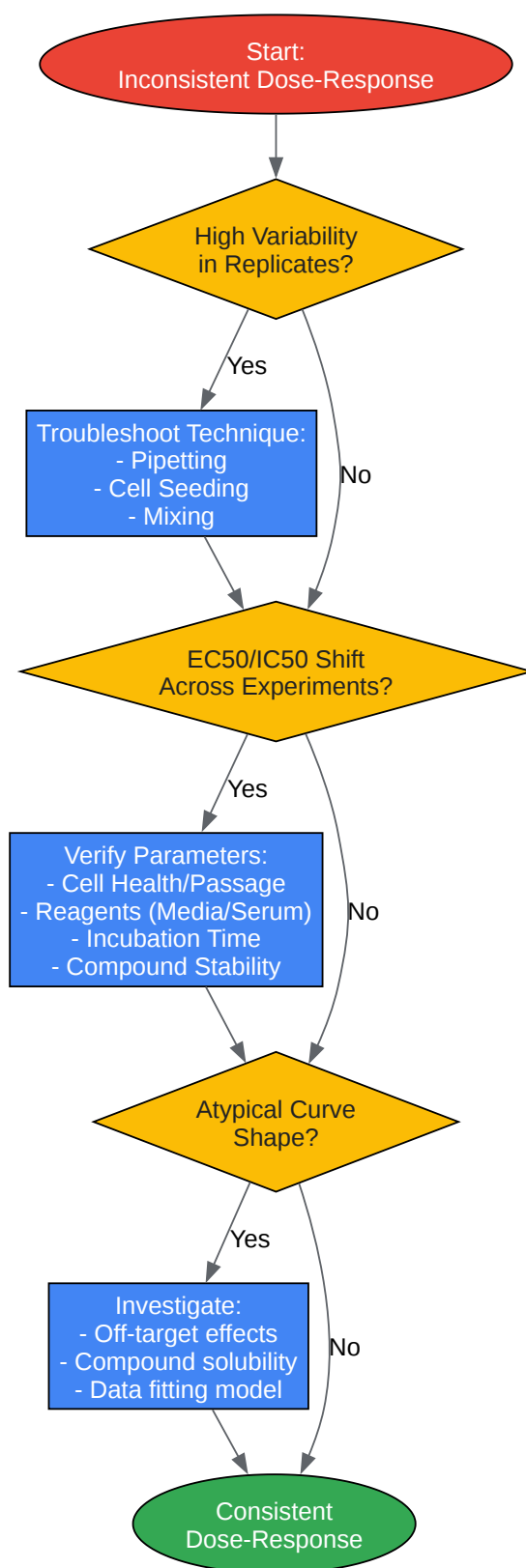

[Click to download full resolution via product page](#)

Caption: Troubleshooting workflow for inconsistent **NS13001** dose-response curves.

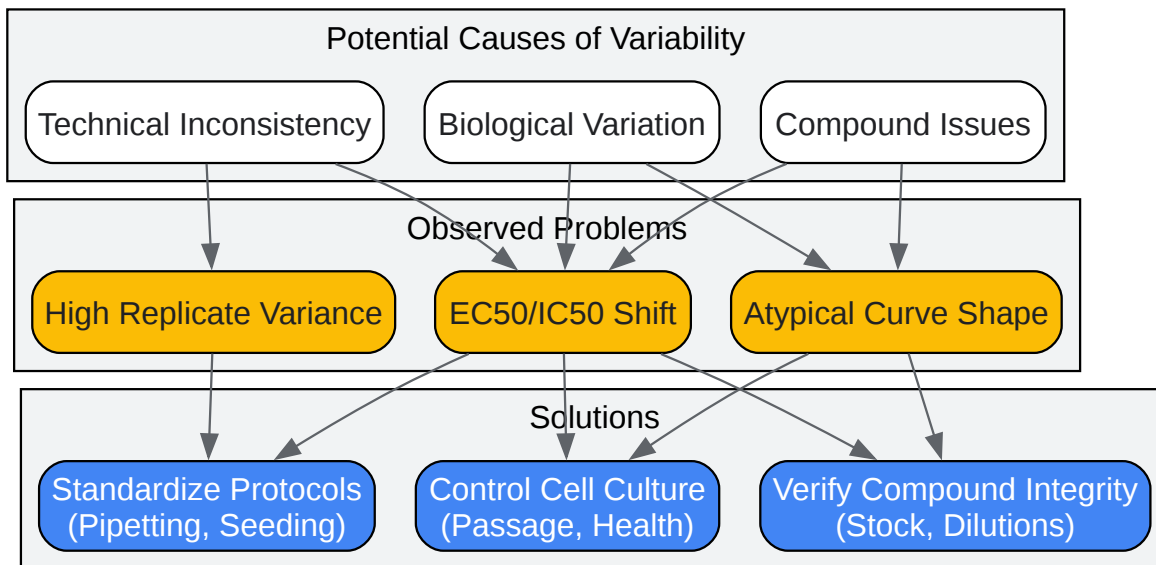

[Click to download full resolution via product page](#)

Caption: Logical relationships between causes, problems, and solutions.

Need Custom Synthesis?

BenchChem offers custom synthesis for rare earth carbides and specific isotopic labeling.

Email: info@benchchem.com or [Request Quote Online](#).

References

- 1. Novel selective positive modulator of calcium-activated potassium channels exerts beneficial effects in a mouse model of spinocerebellar ataxia type 2 - PMC [[pmc.ncbi.nlm.nih.gov](https://pubmed.ncbi.nlm.nih.gov/)]
- 2. Selective positive modulation of the SK3 and SK2 subtypes of small conductance Ca²⁺-activated K⁺ channels - PMC [[pmc.ncbi.nlm.nih.gov](https://pubmed.ncbi.nlm.nih.gov/)]
- 3. [researchgate.net](https://www.researchgate.net/) [[researchgate.net](https://www.researchgate.net/)]
- 4. SK2 channel regulation of neuronal excitability, synaptic transmission, and brain rhythmic activity in health and diseases - PMC [[pmc.ncbi.nlm.nih.gov](https://pubmed.ncbi.nlm.nih.gov/)]

- [5. benchchem.com \[benchchem.com\]](#)
- [6. clyte.tech \[clyte.tech\]](#)
- [7. benchchem.com \[benchchem.com\]](#)
- [8. Use of Different Parameters and Equations for Calculation of IC50 Values in Efflux Assays: Potential Sources of Variability in IC50 Determination - PMC \[pmc.ncbi.nlm.nih.gov\]](#)
- [9. Protocol for Cell Viability Assays: CCK-8 and MTT - Creative Biogene \[creative-biogene.com\]](#)
- [10. broadpharm.com \[broadpharm.com\]](#)
- [11. Emerging Role of Calcium-Activated Potassium Channel in the Regulation of Cell Viability Following Potassium Ions Challenge in HEK293 Cells and Pharmacological Modulation - PMC \[pmc.ncbi.nlm.nih.gov\]](#)
- [12. WST-1 Assay: principles, protocol & best practices for cell viability | Abcam \[abcam.com\]](#)
- [13. Guidelines for accurate EC50/IC50 estimation - PubMed \[pubmed.ncbi.nlm.nih.gov\]](#)
- [14. Perspective: common errors in dose-response analysis and how to avoid them - PubMed \[pubmed.ncbi.nlm.nih.gov\]](#)
- [15. researchgate.net \[researchgate.net\]](#)
- [16. benchchem.com \[benchchem.com\]](#)
- [17. docs.axolbio.com \[docs.axolbio.com\]](#)
- [18. axolbio.com \[axolbio.com\]](#)
- [To cite this document: BenchChem. \[Technical Support Center: Addressing Variability in NS13001 Dose-Response Curves\]. BenchChem, \[2026\]. \[Online PDF\]. Available at: \[https://www.benchchem.com/product/b10775244/docs#technical-support-center-addressing-variability-in-ns13001-dose-response-curves\]](#)

Disclaimer & Data Validity:

The information provided in this document is for Research Use Only (RUO) and is strictly not intended for diagnostic or therapeutic procedures. While BenchChem strives to provide accurate protocols, we make no warranties, express or implied, regarding the fitness of this product for every specific experimental setup.

Technical Support: The protocols provided are for reference purposes. Unsure if this reagent suits your experiment?

Need Industrial/Bulk Grade? [Request Custom Synthesis Quote](#)

BenchChem

Our mission is to be the trusted global source of essential and advanced chemicals, empowering scientists and researchers to drive progress in science and industry.

Contact

Address: 3281 E Guasti Rd

Ontario, CA 91761, United States

Phone: (601) 213-4426

Email: info@benchchem.com

[Contact our Ph.D. Support Team for a compatibility check](#)