

NS13001: A Potent and Selective Positive Modulator of SK2 Channels

Author: BenchChem Technical Support Team. **Date:** April 2026

Compound of Interest

Compound Name: NS13001
Cat. No.: B10775244

[Get Quote](#)

A Comparative Guide for Researchers

This guide provides a comprehensive analysis of **NS13001**, a positive allosteric modulator of small-conductance calcium-activated potassium (SK) channels, with a specific focus on its selectivity for the SK2 subtype over the SK1 subtype. This document is intended for researchers, scientists, and drug development professionals interested in the pharmacological modulation of SK channels for therapeutic applications.

NS13001 has emerged as a valuable pharmacological tool due to its distinct selectivity profile, offering a more targeted approach compared to broader spectrum SK channel activators. Understanding its precise mechanism and selectivity is crucial for its application in studying the physiological roles of SK channel subtypes and for the development of novel therapeutics for neurological disorders such as ataxia.

Comparative Analysis of SK Channel Modulators

NS13001 demonstrates a clear selectivity for SK2 and SK3 channels over SK1 channels. This selectivity is highlighted when comparing its half-maximal effective concentration (EC50) values against other known SK channel modulators like CyPPA and the pan-selective activator NS309.

Compound	SK1 (EC50)	SK2 (EC50)	SK3 (EC50)	Selectivity Profile
NS13001	> 100 μ M	1.6 μ M	0.14 μ M	SK3 > SK2 >>> SK1[1]
CyPPA	Inactive	14 μ M	5.6 μ M	SK3 > SK2 >>> SK1[1]
NS309	~10 μ M	~10 μ M	~10 μ M	Pan-selective (IK > SK1 \approx SK2 \approx SK3)[1]

Mechanism of Action

NS13001 acts as a positive allosteric modulator of SK2 and SK3 channels.[1] It does not directly open the channel but rather increases the apparent sensitivity of the channel to intracellular calcium (Ca^{2+}).[1] This mechanism involves a leftward shift in the Ca^{2+} -activation curve, meaning that lower concentrations of intracellular Ca^{2+} are required to open the channel in the presence of **NS13001**. [1] For instance, in the presence of 1 μ M **NS13001**, the EC50 for Ca^{2+} activation of hSK3 channels shifts from 0.42 μ M to 0.11 μ M.[1] This potentiation of channel activity at sub-maximal Ca^{2+} concentrations is a key feature of its modulatory effect.

Experimental Protocols

The following section details the electrophysiological methods used to characterize the selectivity and potency of **NS13001** on human SK (hSK) channel subtypes.

Cell Culture and Transfection

- Cell Line: Human Embryonic Kidney (HEK293) cells were used for their low endogenous potassium channel expression.
- Transfection: HEK293 cells were stably transfected with plasmids containing the cDNA for either hSK1, hSK2, or hSK3 channel subunits. Successful transfection was typically confirmed by a fluorescent reporter protein co-expressed with the channel.

Electrophysiological Recordings

- Configuration: The inside-out patch-clamp technique was predominantly used to allow for precise control of the intracellular (bath) solution, particularly the free Ca^{2+} concentration.
- Electrodes: Borosilicate glass pipettes were pulled to a resistance of 2-5 $\text{M}\Omega$ when filled with the pipette solution.

Solutions

- Pipette (Intracellular) Solution (in mM): 150 KCl, 10 HEPES, and 10 EGTA. The pH was adjusted to 7.2 with KOH.
- Bath (Extracellular) Solution (in mM): 150 KCl, 10 HEPES, with varying concentrations of CaCl_2 and a Ca^{2+} chelator (e.g., EGTA, BAPTA) to achieve specific free Ca^{2+} concentrations (e.g., 0.2 μM for determining EC_{50} of the compound, and a range of concentrations for determining the Ca^{2+} sensitivity shift). The pH was adjusted to 7.2 with KOH.

Voltage Protocol and Data Acquisition

- Voltage Protocol: A voltage ramp protocol was typically applied to the patch. For example, the membrane potential was ramped from a holding potential of -100 mV to +100 mV over a period of 200 ms. This allows for the measurement of current over a range of voltages in a short period.
- Data Acquisition: Currents were recorded using a patch-clamp amplifier and digitized. Data was acquired and analyzed using software such as pCLAMP.

Data Analysis

- Current Measurement: The current amplitude at a specific negative membrane potential (e.g., -80 mV) was measured at different concentrations of the test compound.
- Normalization: The current in the presence of a test compound was normalized to the maximal current elicited by a saturating concentration of intracellular Ca^{2+} (e.g., 10 μM) in the same patch.
- EC_{50} Calculation: The concentration-response data were fitted to the Hill equation using a non-linear regression analysis in software such as GraphPad Prism to determine the EC_{50}

and Hill coefficient (nH). The Hill equation is as follows: $\text{Response} = \text{Bottom} + (\text{Top} - \text{Bottom}) / (1 + (\text{EC50} / [\text{Drug}])^{\text{HillSlope}})$

Experimental Workflow and Signaling Pathway

The following diagrams illustrate the experimental workflow for assessing the selectivity of **NS13001** and its effect on the SK channel signaling pathway.

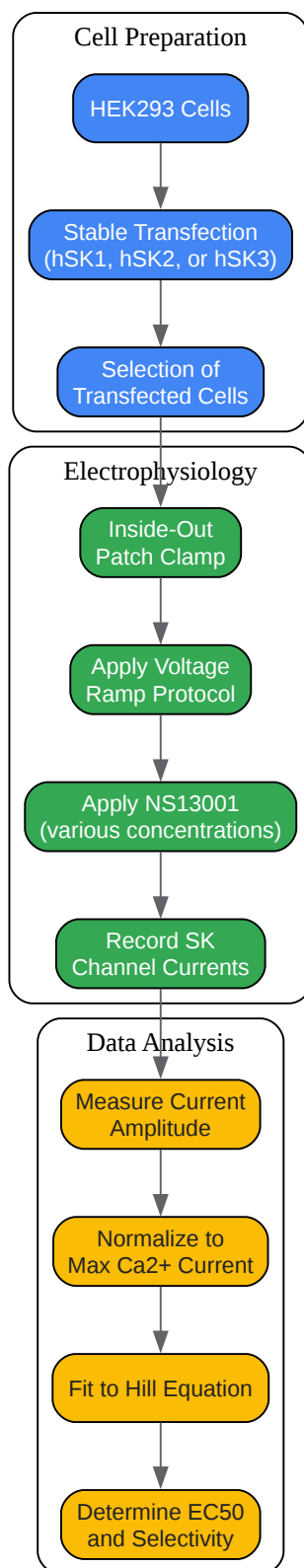

[Click to download full resolution via product page](#)

Fig. 1: Experimental workflow for determining **NS13001** selectivity.

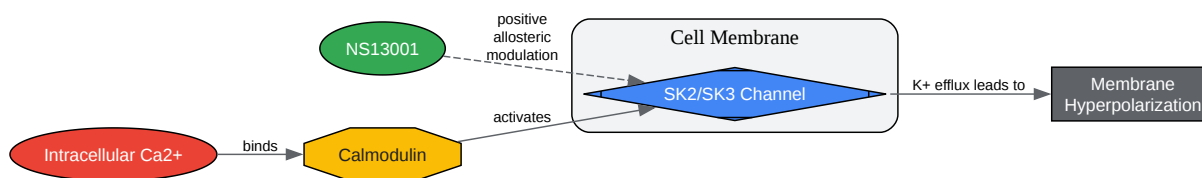

[Click to download full resolution via product page](#)

Fig. 2: **NS13001** mechanism of action on SK channels.

Need Custom Synthesis?

BenchChem offers custom synthesis for rare earth carbides and specific isotopic labeling.

Email: info@benchchem.com or [Request Quote Online](#).

References

- 1. Computational tools for fitting the Hill equation to dose-response curves - PubMed [pubmed.ncbi.nlm.nih.gov]
- To cite this document: BenchChem. [NS13001: A Potent and Selective Positive Modulator of SK2 Channels]. BenchChem, [2026]. [Online PDF]. Available at: [<https://www.benchchem.com/product/b10775244/docs#ns13001-a-potent-and-selective-positive-modulator-of-sk2-channels>]

Disclaimer & Data Validity:

The information provided in this document is for Research Use Only (RUO) and is strictly not intended for diagnostic or therapeutic procedures. While BenchChem strives to provide accurate protocols, we make no warranties, express or implied, regarding the fitness of this product for every specific experimental setup.

Technical Support: The protocols provided are for reference purposes. Unsure if this reagent suits your experiment?

Need Industrial/Bulk Grade? [Request Custom Synthesis Quote](#)

BenchChem

Our mission is to be the trusted global source of essential and advanced chemicals, empowering scientists and researchers to drive progress in science and industry.

Contact

Address: 3281 E Guasti Rd
Ontario, CA 91761, United States
Phone: (601) 213-4426
Email: info@benchchem.com

[Contact our Ph.D. Support Team for a compatibility check](#)