

Application Notes and Protocols for Rapamycin-d3 in Mass Spectrometry-Based Bioanalysis

Author: BenchChem Technical Support Team. **Date:** April 2026

Compound of Interest

Compound Name: *Rapamycin-d3*

Cat. No.: *B10775873*

[Get Quote](#)

For Researchers, Scientists, and Drug Development Professionals

This document provides detailed application notes and protocols for the use of **Rapamycin-d3** as an internal standard in the quantitative bioanalysis of rapamycin (also known as sirolimus) by liquid chromatography-tandem mass spectrometry (LC-MS/MS). These guidelines are intended for researchers, scientists, and professionals involved in drug development and therapeutic drug monitoring.

Introduction

Rapamycin is a potent immunosuppressant and an inhibitor of the mammalian target of rapamycin (mTOR) signaling pathway.^[1] Accurate and precise quantification of rapamycin in biological matrices is crucial for therapeutic drug monitoring and pharmacokinetic studies. The use of a stable isotope-labeled internal standard, such as **Rapamycin-d3**, is the gold standard for LC-MS/MS-based bioanalysis as it effectively compensates for variability in sample preparation and matrix effects, leading to improved accuracy and precision.^[1] **Rapamycin-d3**, being chemically identical to rapamycin but with a mass shift of +3 Da, co-elutes with the analyte and experiences similar ionization efficiency, making it an ideal internal standard.

Mechanism of Action: The mTOR Signaling Pathway

Rapamycin exerts its immunosuppressive and anti-proliferative effects by inhibiting the mTOR kinase, a central regulator of cell growth, proliferation, and metabolism. Rapamycin first binds to the immunophilin FKBP12, and this complex then allosterically inhibits the mTOR Complex 1 (mTORC1).^[1]

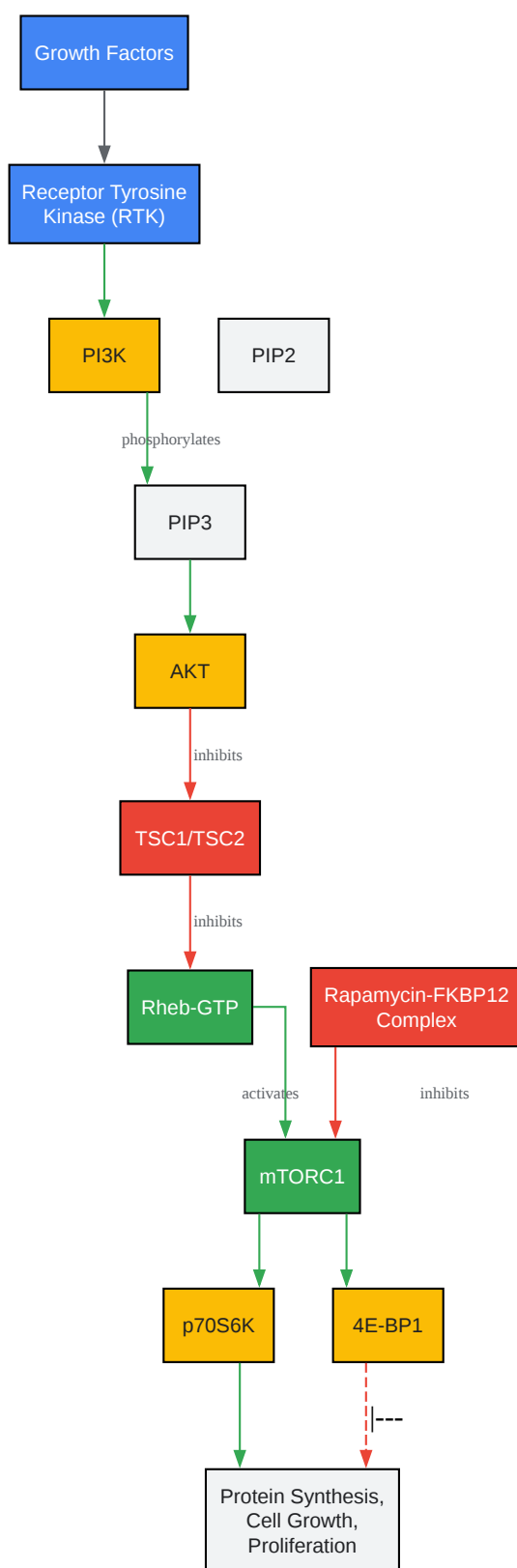

[Click to download full resolution via product page](#)

Caption: Simplified mTOR Signaling Pathway.

Quantitative Data Summary

The following tables summarize the quantitative performance of various LC-MS/MS methods for the analysis of rapamycin using an internal standard.

Table 1: Linearity of Rapamycin Quantification

Biological Matrix	Linearity Range (ng/mL)	Correlation Coefficient (r ²)	Reference
Porcine Whole Blood	0.1 - 100	Not Reported	[2]
Porcine Tissues	0.5 - 500	Not Reported	[2]
Rabbit Ocular Tissues	2.3 - 1000	> 0.9998	[3][4]
Human Whole Blood	0.6 - 49.2	> 0.997	[5]

Table 2: Precision and Accuracy of Rapamycin Quantification

Biological Matrix	Concentration (ng/mL)	Intra-day Precision (%CV)	Inter-day Precision (%CV)	Accuracy (%)	Reference
Human Whole Blood	Not Specified	< 10	< 8	91 - 110	[6]
Human Whole Blood	Not Specified	0.9 - 14.7	2.5 - 12.5	89 - 138 (Intra-day), 90 - 113 (Inter-day)	[5]

Table 3: Recovery and Limit of Quantification (LOQ)

Biological Matrix	Recovery (%)	LOQ (ng/mL)	Reference
Human Whole Blood	76.6 - 84	0.6	[5]
Human Whole Blood	88 ± 26	0.25	[7]
Rabbit Ocular Tissues	Not Reported	2.3	[3][4]
Porcine Whole Blood	Not Reported	0.1	[2]

Experimental Protocols

A generalized experimental workflow for the bioanalysis of rapamycin using **Rapamycin-d3** is presented below. This should be optimized based on the specific matrix and instrumentation.

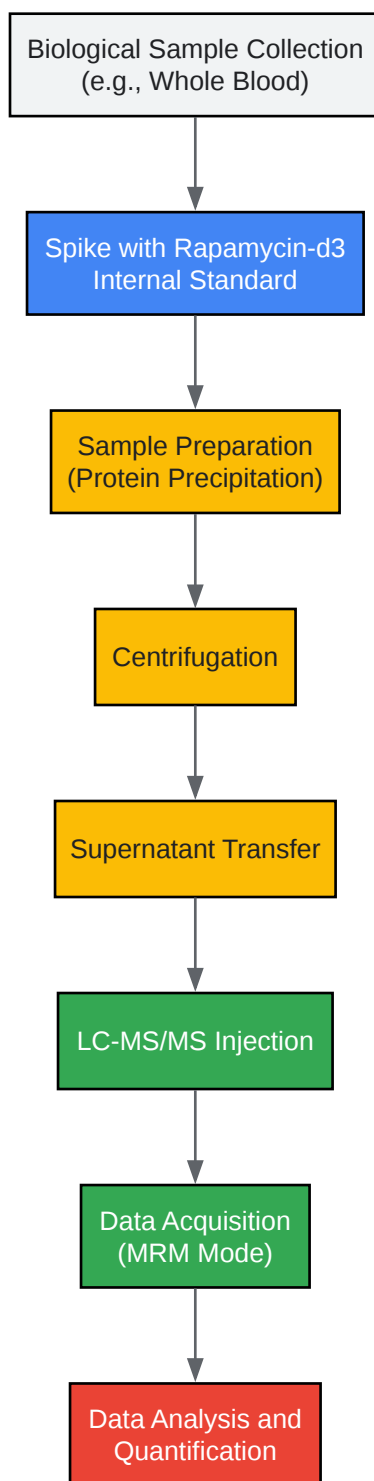

[Click to download full resolution via product page](#)

Caption: Bioanalytical Workflow for Rapamycin.

Materials and Reagents

- Rapamycin certified reference standard
- **Rapamycin-d3** internal standard
- LC-MS grade methanol, acetonitrile, and water
- Formic acid
- Zinc sulfate (optional, for protein precipitation)
- Biological matrix (e.g., whole blood, plasma, tissue homogenate)

Stock and Working Solutions Preparation

- Rapamycin Stock Solution (1 mg/mL): Accurately weigh and dissolve rapamycin in methanol.
- **Rapamycin-d3** Stock Solution (1 mg/mL): Accurately weigh and dissolve **Rapamycin-d3** in methanol.
- Working Solutions: Prepare serial dilutions of the rapamycin stock solution in methanol to create calibration standards and quality control (QC) samples at various concentrations.
- Internal Standard Working Solution: Dilute the **Rapamycin-d3** stock solution with methanol to a final concentration appropriate for spiking into samples (e.g., 0.8 µg/mL).[5]

Sample Preparation (Protein Precipitation)

This is a common and effective method for extracting rapamycin from biological matrices.

- Aliquot 100 µL of the biological sample (calibrator, QC, or unknown) into a microcentrifuge tube.
- Add a specified volume of the **Rapamycin-d3** internal standard working solution.
- Add a protein precipitating agent. A common choice is methanol containing zinc sulfate.[5] For example, add 300 µL of a solution made of 30 mL methanol and 15 mL of 0.1 M zinc sulfate.[5]
- Vortex the mixture for 30-60 seconds to ensure thorough mixing and protein precipitation.

- Centrifuge the samples at a high speed (e.g., 10,000 x g) for 10 minutes to pellet the precipitated proteins.
- Carefully transfer the supernatant to a clean tube or a 96-well plate for LC-MS/MS analysis.

Liquid Chromatography (LC) Parameters

- LC System: A high-performance liquid chromatography (HPLC) or ultra-high-performance liquid chromatography (UHPLC) system.
- Analytical Column: A reversed-phase C18 or C8 column is typically used. Examples include a Zorbax Eclipse XDB C18 (3.0 x 75 mm, 3.5 μ m) or an Xterra C8 (50 mm x 4.6 mm, 5 μ m).
[3][5]
- Mobile Phase A: Water with 0.1% formic acid.
- Mobile Phase B: Acetonitrile or methanol with 0.1% formic acid.
- Gradient: A gradient elution is typically employed to separate rapamycin from matrix components. The specific gradient will depend on the column and system used.
- Flow Rate: Dependent on the column dimensions, typically in the range of 0.3-0.6 mL/min.
- Column Temperature: Maintained at a constant temperature, for example, 40°C or 60°C.[3]
[5]
- Injection Volume: Typically 5-20 μ L.[3]

Mass Spectrometry (MS) Parameters

- Mass Spectrometer: A triple quadrupole mass spectrometer.
- Ionization Source: Electrospray ionization (ESI) in positive ion mode is commonly used.[3][4]
- Multiple Reaction Monitoring (MRM) Transitions:
 - Rapamycin: The sodium adduct $[M+Na]^+$ at m/z 936.6 is often selected as the parent ion, with a common product ion being m/z 409.3.[3][4] Other adducts like ammonium

[M+NH₄]⁺ may also be monitored.

- **Rapamycin-d3**: The corresponding sodium adduct [M+3+Na]⁺ at m/z 939.6 would be the parent ion, with the same product ion of m/z 409.3. The exact m/z values should be confirmed by direct infusion of the standards.
- Ion Source Parameters: Optimize parameters such as ion spray voltage, source temperature, and gas flows (nebulizer, curtain, and collision gas) to achieve maximum signal intensity for both rapamycin and **Rapamycin-d3**.

Data Analysis and Quantification

The concentration of rapamycin in the unknown samples is determined by calculating the peak area ratio of the analyte to the internal standard (Rapamycin/**Rapamycin-d3**). A calibration curve is constructed by plotting the peak area ratios of the calibration standards against their known concentrations. The concentration of rapamycin in the unknown samples is then interpolated from this calibration curve.

Conclusion

The use of **Rapamycin-d3** as an internal standard provides a robust, sensitive, and specific method for the quantification of rapamycin in various biological matrices by LC-MS/MS. The protocols and data presented here offer a comprehensive guide for the development and validation of bioanalytical methods for rapamycin, which are essential for clinical and research applications.

Need Custom Synthesis?

BenchChem offers custom synthesis for rare earth carbides and specific isotopic labeling.

Email: info@benchchem.com or [Request Quote Online](#).

References

- [1. caymanchem.com](http://caymanchem.com) [caymanchem.com]
- [2. BASi® | Development And Validation Of An Lc-ms/ms Method For The Quantification Of Rapamycin In Porcine Whole Blood And Tissues](#) [basinc.com]

- 3. Bioanalytical method validation of rapamycin in ocular matrix by QTRAP LC–MS/MS: Application to rabbit anterior tissue distribution by topical administration of rapamycin nanomicellar formulation - PMC [[pmc.ncbi.nlm.nih.gov](https://pubmed.ncbi.nlm.nih.gov)]
- 4. Bioanalytical method validation of rapamycin in ocular matrix by QTRAP LC-MS/MS: application to rabbit anterior tissue distribution by topical administration of rapamycin nanomicellar formulation - PubMed [pubmed.ncbi.nlm.nih.gov]
- 5. Validation of an LC-MS/MS method to determine five immunosuppressants with deuterated internal standards including MPA - PMC [[pmc.ncbi.nlm.nih.gov](https://pubmed.ncbi.nlm.nih.gov)]
- 6. Comparing the effect of isotopically labeled or structural analog internal standards on the performance of a LC-MS/MS method to determine ciclosporin A, everolimus, sirolimus and tacrolimus in whole blood - PubMed [pubmed.ncbi.nlm.nih.gov]
- 7. Sensitive and specific quantification of sirolimus (rapamycin) and its metabolites in blood of kidney graft recipients by HPLC/electrospray-mass spectrometry - PubMed [pubmed.ncbi.nlm.nih.gov]
- To cite this document: BenchChem. [Application Notes and Protocols for Rapamycin-d3 in Mass Spectrometry-Based Bioanalysis]. BenchChem, [2026]. [Online PDF]. Available at: [<https://www.benchchem.com/product/b10775873/docs#application-notes-and-protocols-for-rapamycin-d3-in-mass-spectrometry-based-bioanalysis>]

Disclaimer & Data Validity:

The information provided in this document is for Research Use Only (RUO) and is strictly not intended for diagnostic or therapeutic procedures. While BenchChem strives to provide accurate protocols, we make no warranties, express or implied, regarding the fitness of this product for every specific experimental setup.

Technical Support: The protocols provided are for reference purposes. Unsure if this reagent suits your experiment?

Need Industrial/Bulk Grade? [Request Custom Synthesis Quote](#)

BenchChem

Our mission is to be the trusted global source of essential and advanced chemicals, empowering scientists and researchers to drive progress in science and industry.

Contact

Address: 3281 E Guasti Rd
Ontario, CA 91761, United States
Phone: (601) 213-4426
Email: info@benchchem.com

[Contact our Ph.D. Support Team for a compatibility check](#)