

# Application Notes and Protocols for Maraviroc Sample Extraction Using Maraviroc-d6

**Author:** BenchChem Technical Support Team. **Date:** April 2026

## Compound of Interest

Compound Name: Maraviroc-d6

Cat. No.: B10775544

[Get Quote](#)

For Researchers, Scientists, and Drug Development Professionals

This document provides detailed application notes and protocols for the extraction of Maraviroc from human plasma samples for quantitative analysis, utilizing **Maraviroc-d6** as a stable isotope-labeled internal standard. The methodologies described are based on established bioanalytical techniques and are suitable for pharmacokinetic studies, therapeutic drug monitoring, and clinical trial sample analysis.

## Introduction

Maraviroc is an antiretroviral drug belonging to the class of CCR5 receptor antagonists. It is used in the treatment of HIV-1 infection. Accurate and precise quantification of Maraviroc in biological matrices is crucial for understanding its pharmacokinetics and ensuring therapeutic efficacy. The use of a stable isotope-labeled internal standard, **Maraviroc-d6**, is the gold standard for mass spectrometry-based quantification as it corrects for variability in sample preparation and instrument response.

This document outlines two common and effective sample extraction techniques: Protein Precipitation and Solid-Phase Extraction (SPE). Both methods are widely used in bioanalytical

laboratories and offer distinct advantages depending on the specific requirements of the assay, such as sample throughput, required sensitivity, and the complexity of the sample matrix.

## Mechanism of Action: Maraviroc and CCR5 Signaling

Maraviroc is a selective, slowly reversible antagonist of the C-C chemokine receptor type 5 (CCR5), which is a coreceptor used by the most common strains of HIV-1 to enter host CD4+ T-cells. By binding to CCR5, Maraviroc allosterically inhibits the interaction between the viral glycoprotein gp120 and the host cell coreceptor, thereby preventing the conformational changes necessary for the fusion of the viral and cellular membranes. This action effectively blocks the entry of CCR5-tropic HIV-1 into the cell.

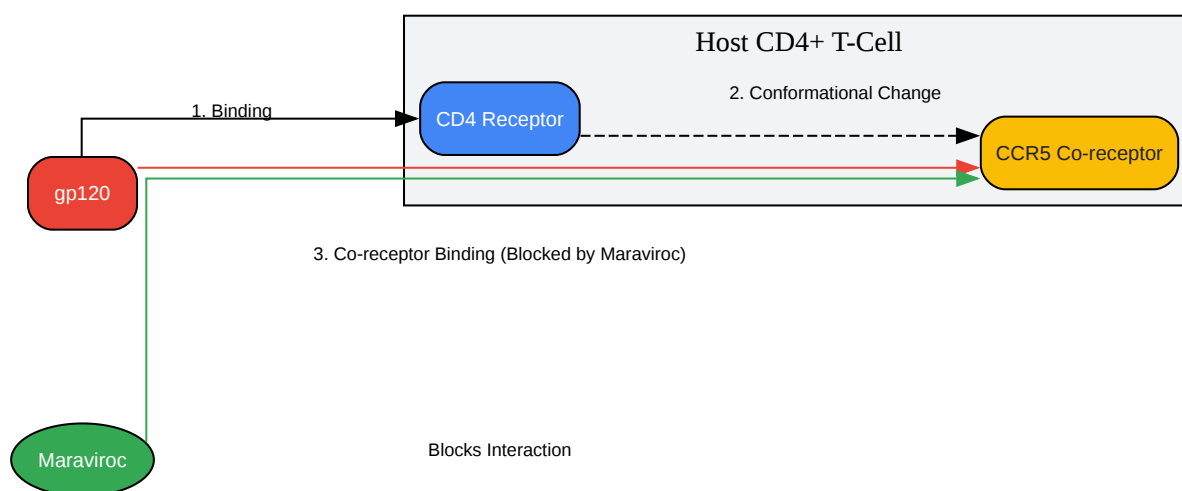

[Click to download full resolution via product page](#)

Figure 1. Maraviroc's mechanism of action in blocking HIV-1 entry.

## Quantitative Data Summary

The following tables summarize typical validation parameters for the quantification of Maraviroc in human plasma using LC-MS/MS with **Maraviroc-d6** as an internal standard.

Table 1: Method Validation Parameters

Parameter	Protein Precipitation	Solid-Phase Extraction
Linearity Range	0.5 - 1000 ng/mL[1]	1 - 2500 ng/mL
Lower Limit of Quantification (LLOQ)	0.5 ng/mL[1]	1 ng/mL
Inter-assay Precision (%CV)	≤ 5.38%[1]	< 15%
Intra-assay Precision (%CV)	≤ 5.98%[1]	< 15%
Inter-assay Accuracy (%DEV)	≤ 10.2%[1]	± 15%
Intra-assay Accuracy (%DEV)	≤ 8.44%[1]	± 15%
Mean Recovery	> 85%[2]	> 90%

## Experimental Protocols

### Protein Precipitation Method

This method is rapid, simple, and suitable for high-throughput analysis. It involves the addition of an organic solvent to the plasma sample to precipitate proteins, which are then removed by centrifugation.

Materials and Reagents:

- Human plasma (K2 EDTA)
- Maraviroc reference standard
- **Maraviroc-d6** internal standard stock solution (e.g., 1 µg/mL in methanol)
- Acetonitrile (HPLC grade)
- Methanol (HPLC grade)
- Water (HPLC grade)

- Microcentrifuge tubes (1.5 mL)
- Calibrated pipettes
- Vortex mixer
- Microcentrifuge
- Sample evaporator (optional)

Protocol:

- Preparation of Standards and Quality Controls (QCs):
  - Prepare a series of Maraviroc working solutions by diluting a stock solution with methanol or acetonitrile.
  - Spike blank human plasma with the appropriate working solutions to create calibration standards (e.g., 0.5, 1, 5, 10, 50, 100, 250, 500, 1000 ng/mL) and QC samples (low, mid, high concentrations).
- Sample Preparation:
  - Pipette 100  $\mu$ L of plasma sample, calibration standard, or QC into a 1.5 mL microcentrifuge tube.
  - Add 10  $\mu$ L of **Maraviroc-d6** internal standard working solution (e.g., 100 ng/mL) to each tube and vortex briefly.
  - Add 300  $\mu$ L of ice-cold acetonitrile to each tube to precipitate the plasma proteins.
  - Vortex mix thoroughly for 1 minute.
- Centrifugation:
  - Centrifuge the tubes at 14,000 x g for 10 minutes at 4°C to pellet the precipitated proteins.
- Supernatant Transfer:

- Carefully transfer the supernatant to a clean tube or a 96-well plate.
- Evaporation and Reconstitution (Optional but Recommended):
  - Evaporate the supernatant to dryness under a stream of nitrogen at approximately 40°C.
  - Reconstitute the dried extract in 100  $\mu$ L of a suitable mobile phase (e.g., 50:50 acetonitrile:water) and vortex to dissolve the residue.
- Analysis:
  - Inject an appropriate volume (e.g., 5-10  $\mu$ L) of the reconstituted sample into the LC-MS/MS system for analysis.

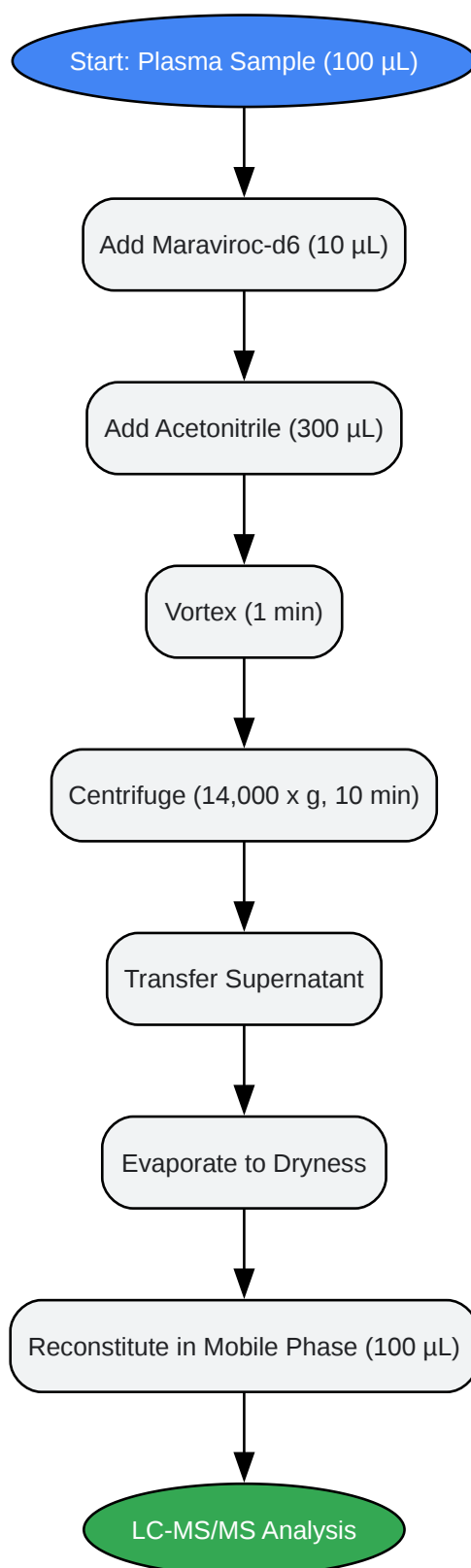

[Click to download full resolution via product page](#)

Figure 2. Protein Precipitation Workflow for Maraviroc Extraction.

## Solid-Phase Extraction (SPE) Method

SPE provides a cleaner extract compared to protein precipitation by removing more matrix components, which can reduce ion suppression in the mass spectrometer and improve assay sensitivity.

### Materials and Reagents:

- Human plasma (K2 EDTA)
- Maraviroc reference standard
- Maraviro-d6 internal standard stock solution
- Oasis HLB SPE cartridges (e.g., 1 cc, 30 mg)
- Methanol (HPLC grade)
- Acetonitrile (HPLC grade)
- Water (HPLC grade)
- Formic acid or phosphoric acid (for sample pre-treatment)
- SPE vacuum manifold
- Calibrated pipettes
- Vortex mixer
- Sample evaporator

### Protocol:

- Preparation of Standards and QCs:
  - Prepare calibration standards and QC samples in blank human plasma as described in the protein precipitation protocol.

- Sample Pre-treatment:
  - Pipette 200  $\mu$ L of plasma sample, standard, or QC into a clean tube.
  - Add 20  $\mu$ L of **Maraviroc-d6** internal standard working solution and vortex.
  - Dilute the plasma sample 1:1 with an acidic solution (e.g., 4% phosphoric acid in water) to disrupt protein binding.
- SPE Cartridge Conditioning:
  - Place the Oasis HLB SPE cartridges on the vacuum manifold.
  - Condition the cartridges by passing 1 mL of methanol through them.
  - Equilibrate the cartridges by passing 1 mL of water through them. Do not allow the cartridges to dry out before loading the sample.
- Sample Loading:
  - Load the pre-treated plasma sample onto the conditioned SPE cartridge.
  - Apply a gentle vacuum to slowly draw the sample through the sorbent at a flow rate of approximately 1 mL/min.
- Washing:
  - Wash the cartridge with 1 mL of a weak organic solvent solution (e.g., 5% methanol in water) to remove polar interferences.
  - Dry the cartridge under high vacuum for 1-2 minutes to remove excess wash solvent.
- Elution:
  - Place clean collection tubes or a 96-well plate inside the manifold.
  - Elute Maraviroc and **Maraviroc-d6** from the cartridge with 1 mL of methanol or acetonitrile.

- Evaporation and Reconstitution:
  - Evaporate the eluate to dryness under a stream of nitrogen at approximately 40°C.
  - Reconstitute the dried extract in 100 µL of a suitable mobile phase.
- Analysis:
  - Inject an appropriate volume of the reconstituted sample into the LC-MS/MS system.

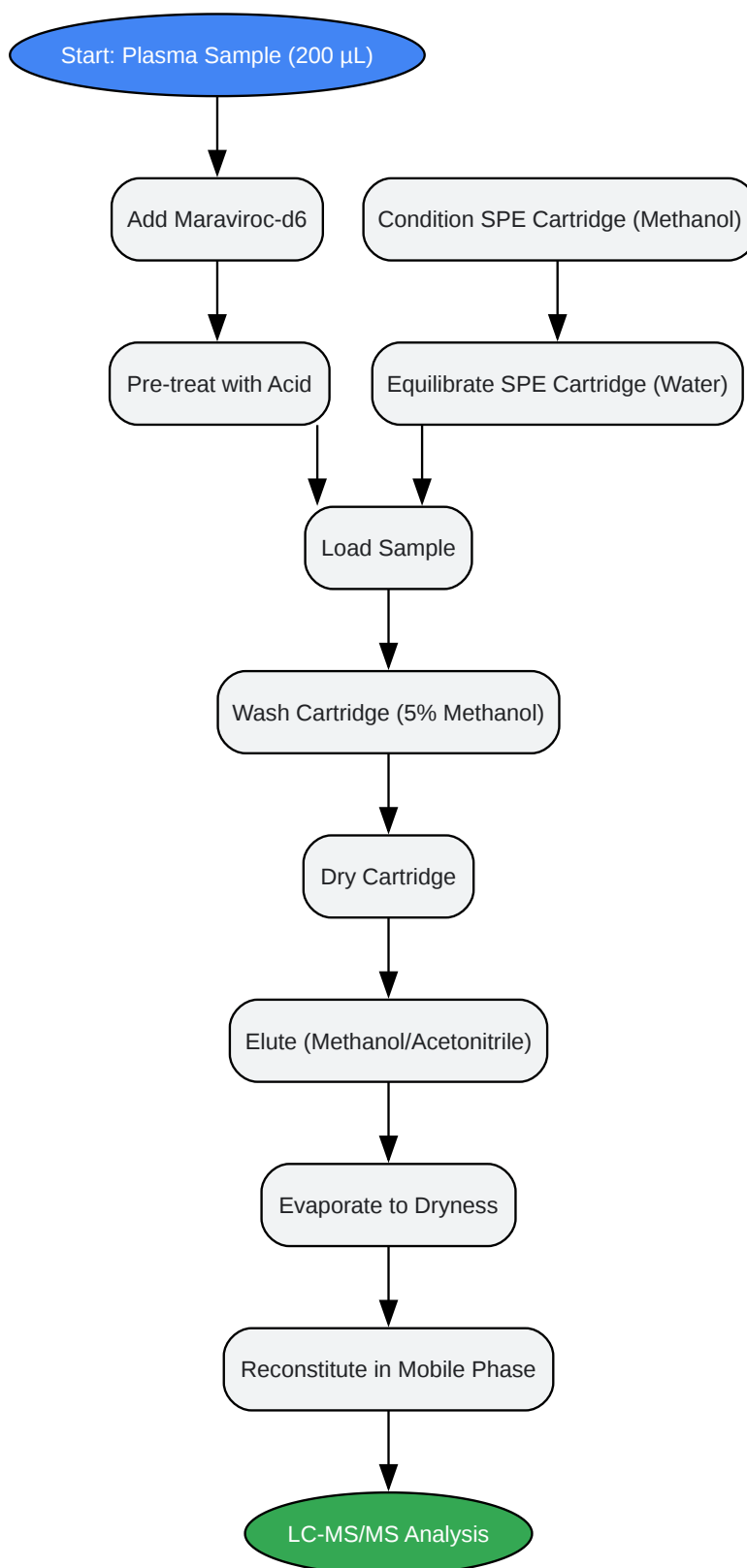

[Click to download full resolution via product page](#)

### Need Custom Synthesis?

BenchChem offers custom synthesis for rare earth carbides and specific isotopic labeling.

Email: [info@benchchem.com](mailto:info@benchchem.com) or [Request Quote Online](#).

## References

- [1. lcms.cz \[lcms.cz\]](#)
- [2. Simultaneous determination of maraviroc and raltegravir in human plasma by HPLC-UV - PubMed \[pubmed.ncbi.nlm.nih.gov\]](#)
- To cite this document: BenchChem. [Application Notes and Protocols for Maraviroc Sample Extraction Using Maraviroc-d6]. BenchChem, [2026]. [Online PDF]. Available at: [\[https://www.benchchem.com/product/b10775544/docs#application-notes-and-protocols-for-maraviroc-sample-extraction-using-maraviroc-d6\]](https://www.benchchem.com/product/b10775544/docs#application-notes-and-protocols-for-maraviroc-sample-extraction-using-maraviroc-d6)

### Disclaimer & Data Validity:

The information provided in this document is for Research Use Only (RUO) and is strictly not intended for diagnostic or therapeutic procedures. While BenchChem strives to provide accurate protocols, we make no warranties, express or implied, regarding the fitness of this product for every specific experimental setup.

**Technical Support:** The protocols provided are for reference purposes. Unsure if this reagent suits your experiment?

**Need Industrial/Bulk Grade?** [Request Custom Synthesis Quote](#)

## BenchChem

Our mission is to be the trusted global source of essential and advanced chemicals, empowering scientists and researchers to drive progress in science and industry.

### Contact

Address: 3281 E Guasti Rd  
Ontario, CA 91761, United States  
Phone: (601) 213-4426  
Email: [info@benchchem.com](mailto:info@benchchem.com)

Contact our Ph.D. Support Team for a compatibility check