

An In-depth Technical Guide on the Downstream Signaling Pathways Affected by TAS0728

Author: BenchChem Technical Support Team. **Date:** April 2026

Compound of Interest

Compound Name: TAS0728
Cat. No.: B10775276

[Get Quote](#)

For Researchers, Scientists, and Drug Development Professionals

Introduction

TAS0728 is a novel, orally available, covalent inhibitor of Human Epidermal Growth Factor Receptor 2 (HER2). It selectively and irreversibly binds to the cysteine residue (C805) within the ATP-binding site of HER2, leading to potent and sustained inhibition of its kinase activity. This targeted mechanism of action makes **TAS0728** a promising therapeutic agent for HER2-driven malignancies. This technical guide provides a comprehensive overview of the downstream signaling pathways modulated by **TAS0728**, supported by quantitative data, detailed experimental protocols, and visual pathway diagrams.

Mechanism of Action

TAS0728 forms a covalent bond with the C805 residue of the HER2 kinase domain, which confers its high potency and irreversible nature. This covalent binding prevents ATP from accessing the kinase domain, thereby inhibiting HER2 autophosphorylation and subsequent activation of downstream signaling cascades. A key feature of **TAS0728** is its high selectivity for HER2 over other members of the ErbB family, particularly the epidermal growth factor receptor

(EGFR), which may translate to a more favorable safety profile compared to pan-ErbB inhibitors.

Impact on Downstream Signaling Pathways

TAS0728 demonstrates robust and sustained inhibition of key signaling pathways that are critical for the proliferation and survival of HER2-amplified cancer cells. The primary pathways affected are the PI3K/AKT/mTOR and MAPK/ERK pathways.

The PI3K/AKT/mTOR Pathway

The Phosphoinositide 3-kinase (PI3K)/protein kinase B (AKT)/mammalian target of rapamycin (mTOR) pathway is a crucial signaling cascade that regulates cell growth, proliferation, and survival. In HER2-overexpressing cancers, this pathway is often constitutively active. **TAS0728** effectively abrogates this signaling by inhibiting the phosphorylation of HER2 and its dimerization partner, HER3. This leads to a significant reduction in the phosphorylation of downstream effectors, including AKT and S6 ribosomal protein.

The MAPK/ERK Pathway

The Mitogen-Activated Protein Kinase (MAPK)/Extracellular signal-regulated kinase (ERK) pathway is another critical downstream cascade of HER2 that regulates cell proliferation, differentiation, and survival. Inhibition of HER2 phosphorylation by **TAS0728** leads to a marked decrease in the phosphorylation of MEK and ERK, key components of this pathway.

The inhibition of both the PI3K/AKT/mTOR and MAPK/ERK pathways by **TAS0728** culminates in the induction of apoptosis in HER2-amplified cancer cells.[1]

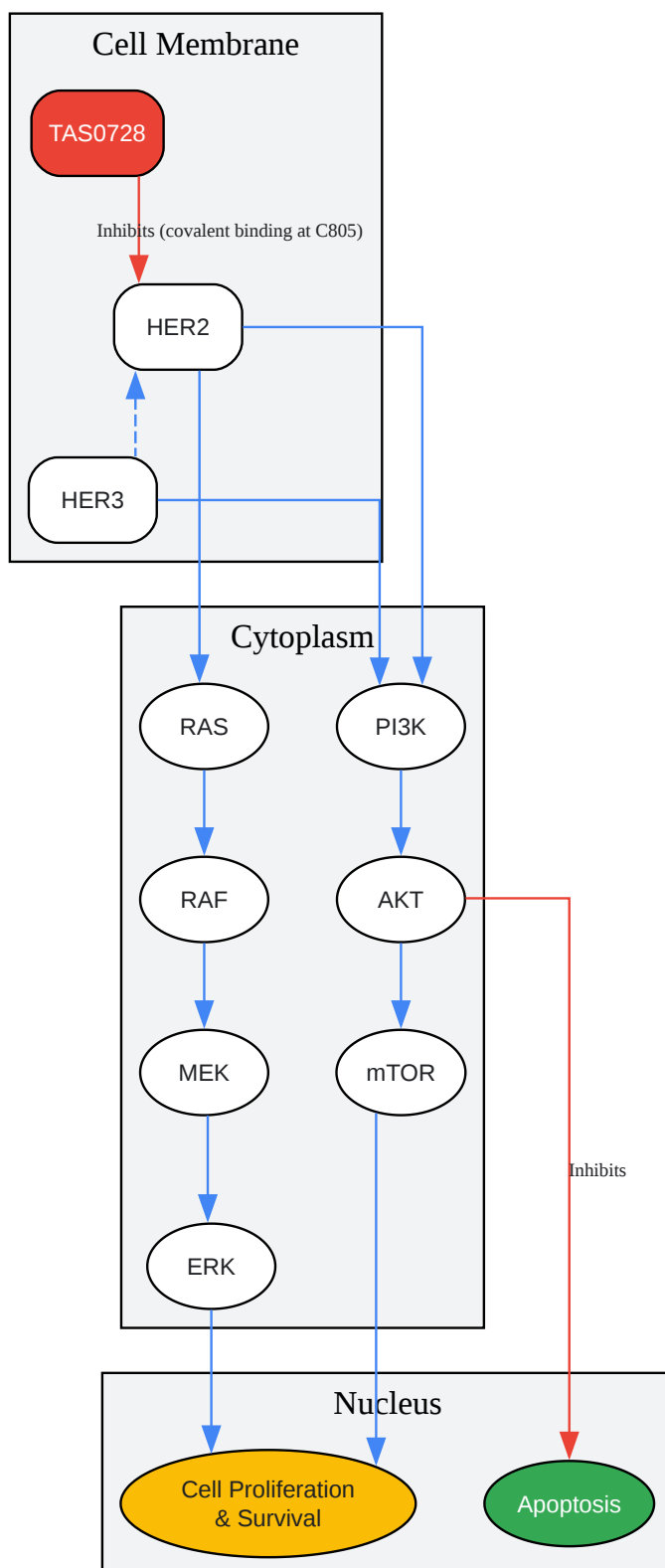

[Click to download full resolution via product page](#)

Figure 1: TAS0728 inhibits HER2, blocking PI3K/AKT and MAPK pathways.

Quantitative Analysis of TAS0728 Activity

The potency and selectivity of **TAS0728** have been characterized through various in vitro assays.

Biochemical and Cellular Potency

Assay Type	Target/Cell Line	Metric	Value (nM)
Biochemical Assay	HER2	IC50	36
Cellular Assay	BT-474	GI50	3.6
Cellular Assay	NCI-N87	GI50	1.6 - 31
Cellular Assay	SK-BR-3	GI50	1.6 - 31
Cellular Assay	CALU-3	GI50	1.6 - 31
Cellular Assay	MDA-MB-453	GI50	1.6 - 31
Cellular Assay	JIMT-1	GI50	1.6 - 31

IC50: Half maximal inhibitory concentration. GI50: 50% growth inhibition.

Kinase Selectivity

A kinome-wide biochemical panel demonstrated the high specificity of **TAS0728** for HER2. At a concentration of 1 μ M, **TAS0728** showed significant inhibition of HER2 while sparing a large panel of other kinases, including EGFR.

Experimental Protocols

Cell Viability Assay

Objective: To determine the growth inhibitory effect of **TAS0728** on HER2-amplified cancer cell lines.

Methodology:

- Cell Culture: HER2-amplified human cancer cell lines (e.g., NCI-N87, BT-474, SK-BR-3) are cultured in appropriate media supplemented with fetal bovine serum and antibiotics.

- Treatment: Cells are seeded in 96-well plates and treated with a serial dilution of **TAS0728** or vehicle control (DMSO) for a specified duration (e.g., 72 hours).
- Viability Assessment: Cell viability is assessed using a commercial reagent such as CellTiter-Glo® (Promega), which measures ATP levels as an indicator of metabolically active cells.
- Data Analysis: Luminescence is measured using a plate reader. The GI50 values are calculated by fitting the dose-response data to a four-parameter logistic curve using appropriate software (e.g., GraphPad Prism).



[Click to download full resolution via product page](#)

Figure 2: Workflow for determining cell viability after **TAS0728** treatment.

Western Blot Analysis for Phosphoprotein Levels

Objective: To quantify the inhibition of HER2, HER3, AKT, and ERK phosphorylation by **TAS0728**.

Methodology:

- Cell Lysis: Cells are treated with **TAS0728** for the desired time, then washed with ice-cold PBS and lysed with a buffer containing protease and phosphatase inhibitors.
- Protein Quantification: Protein concentration in the lysates is determined using a BCA protein assay.
- SDS-PAGE and Transfer: Equal amounts of protein are separated by SDS-PAGE and transferred to a PVDF membrane.
- Immunoblotting: Membranes are blocked and then incubated with primary antibodies specific for total and phosphorylated forms of HER2, HER3, AKT, and ERK.

- **Detection:** After incubation with HRP-conjugated secondary antibodies, protein bands are visualized using an enhanced chemiluminescence (ECL) detection system.
- **Densitometry:** Band intensities are quantified using image analysis software (e.g., ImageJ) to determine the relative levels of phosphorylated proteins.

In Vivo Antitumor Activity in Xenograft Models

Objective: To evaluate the in vivo efficacy of **TAS0728** in mouse xenograft models of HER2-amplified cancer.

Methodology:

- **Animal Models:** Female athymic nude mice are used.
- **Tumor Implantation:** HER2-amplified cancer cells (e.g., NCI-N87, BT-474) are subcutaneously implanted into the flanks of the mice.
- **Treatment:** Once tumors reach a palpable size, mice are randomized into treatment and control groups. **TAS0728** is administered orally at specified doses (e.g., 30 and 60 mg/kg) and schedules.
- **Tumor Measurement:** Tumor volume is measured regularly using calipers.
- **Pharmacodynamic Analysis:** At the end of the study, tumors may be excised for Western blot analysis of phosphoprotein levels to confirm target engagement.
- **Data Analysis:** Tumor growth inhibition is calculated, and statistical significance is determined.

Conclusion

TAS0728 is a potent and selective covalent inhibitor of HER2 that effectively blocks downstream signaling through the PI3K/AKT/mTOR and MAPK/ERK pathways. This leads to the inhibition of cell proliferation and induction of apoptosis in HER2-driven cancer models. The quantitative data and experimental protocols provided in this guide offer a comprehensive resource for researchers and drug development professionals working on HER2-targeted

therapies. The high potency and selectivity of **TAS0728** underscore its potential as a valuable therapeutic agent for patients with HER2-positive cancers.

Need Custom Synthesis?

BenchChem offers custom synthesis for rare earth carbides and specific isotopic labeling.

Email: info@benchchem.com or [Request Quote Online](#).

References

- [1. TAS0728, A Covalent-binding, HER2-selective Kinase Inhibitor Shows Potent Antitumor Activity in Preclinical Models - PubMed \[pubmed.ncbi.nlm.nih.gov\]](#)
- To cite this document: BenchChem. [An In-depth Technical Guide on the Downstream Signaling Pathways Affected by TAS0728]. BenchChem, [2026]. [Online PDF]. Available at: [<https://www.benchchem.com/product/b10775276/docs#an-in-depth-technical-guide-on-the-downstream-signaling-pathways-affected-by-tas0728>]

Disclaimer & Data Validity:

The information provided in this document is for Research Use Only (RUO) and is strictly not intended for diagnostic or therapeutic procedures. While BenchChem strives to provide accurate protocols, we make no warranties, express or implied, regarding the fitness of this product for every specific experimental setup.

Technical Support: The protocols provided are for reference purposes. Unsure if this reagent suits your experiment?

Need Industrial/Bulk Grade? [Request Custom Synthesis Quote](#)

BenchChem

Our mission is to be the trusted global source of essential and advanced chemicals, empowering scientists and researchers to drive progress in science and industry.

Contact

Address: 3281 E Guasti Rd

Ontario, CA 91761, United States

Phone: (601) 213-4426

Email: info@benchchem.com

[Contact our Ph.D. Support Team for a compatibility check](#)