

Application Notes and Protocols: Ammonium Chloride in Bacterial Growth Media

Author: BenchChem Technical Support Team. **Date:** April 2026

Compound of Interest

Compound Name: Ammonium Chloride

CAS No.: 54450-56-5

Cat. No.: B10774519

[Get Quote](#)

For Researchers, Scientists, and Drug Development Professionals

Introduction

Ammonium chloride (NH₄Cl) is a crucial component in many bacterial growth media, serving as a primary source of nitrogen.[1][2] Nitrogen is an essential element for the synthesis of fundamental cellular macromolecules, including amino acids, nucleic acids, and proteins.[2][3] The ability of bacteria to assimilate nitrogen from inorganic sources like **ammonium chloride** is fundamental to their growth and proliferation.[2] These application notes provide detailed protocols and data on the utilization of **ammonium chloride** in bacterial culture, offering insights for media optimization and metabolic studies.

Chemical and Physical Properties

Ammonium chloride is a white, crystalline salt that is highly soluble in water.[1] This property makes it an ideal and readily available nitrogen source for bacteria in liquid culture and on solid agar plates.[1][2]

Role in Bacterial Metabolism

Bacteria primarily assimilate ammonium via two key enzymatic pathways:

- **Glutamate Dehydrogenase (GDH) Pathway:** This pathway involves the reductive amination of α -ketoglutarate to glutamate.
- **Glutamine Synthetase-Glutamate Synthase (GS-GOGAT) Pathway:** This is a cyclic pathway that incorporates ammonium into glutamate via glutamine. This pathway is particularly important under nitrogen-limiting conditions due to the high affinity of glutamine synthetase for ammonium.

The assimilated nitrogen is then utilized in various biosynthetic pathways to produce essential cellular components.

Quantitative Data Summary

The concentration of **ammonium chloride** can significantly impact bacterial growth, with effects varying between species and the composition of the basal medium. Below is a summary of quantitative data from studies investigating the effects of **ammonium chloride** on bacterial growth.

Bacterium	Medium	NH ₄ Cl Concentration	Observation	Reference
Streptomyces luridiscabiei	---	0.16 mg/L	Highest biomass production (1.42 ± 0.14 mg/mL) on day 10.	[4]
3.0 mg/L	Highest biomass production (1.26 mg/mL) on day 7.	[4]		
7.5 mg/L	Initial suppression of biomass production, but no significant difference from other concentrations for most of the study period.	[4]		
Escherichia coli DH5α	LB Lennox	1 g/L	No significant difference in growth profile compared to control.	[5]
4 g/L	No significant difference in growth profile compared to control.	[5]		
Selenomonas ruminantium	---	0.5 mM	Yields of 25.1 g cells/mol glucose and 13.9 g cells/mol ATP.	[3]

>0.5 mM	Yields were nearly doubled compared to 0.5 mM.	[3]	
Aeribacillus pallidus sp. GW-E	HNM, ADM-1, ADM-2	Not specified	100% NH ₄ ⁺ -N utilization efficiency under optimized conditions (C/N ratio of 15, 54°C, pH 8). [6]

Signaling Pathway: Nitrogen Assimilation

The following diagram illustrates the primary pathways for ammonium assimilation in bacteria.

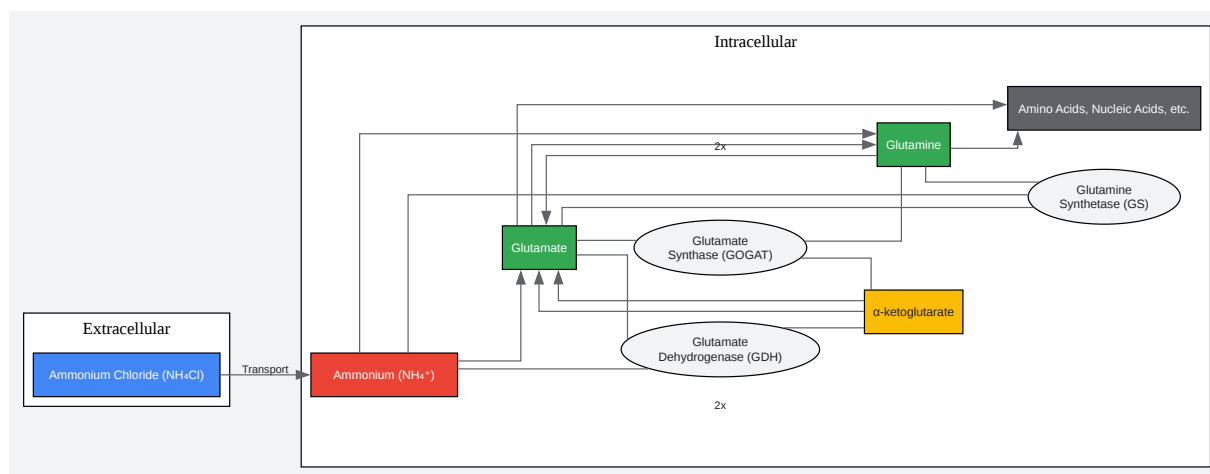

[Click to download full resolution via product page](#)

Bacterial Nitrogen Assimilation Pathways

Experimental Protocols

Protocol 1: Preparation of M9 Minimal Medium

This protocol describes the preparation of M9 minimal medium, where **ammonium chloride** is the sole nitrogen source.

Materials:

- 5X M9 Salts Solution:
 - 64 g Na₂HPO₄·7H₂O

- 15 g KH_2PO_4
- 2.5 g NaCl
- 5.0 g NH_4Cl
- Add ddH₂O to a final volume of 1 L
- 2 M MgSO_4 (sterile)
- 1 M CaCl_2 (sterile)
- 20% Glucose (sterile)
- Agar (for solid medium)
- Sterile ddH₂O

Procedure:

- For 1 L of M9 liquid medium:
 - To 750 mL of sterile ddH₂O, add 200 mL of 5X M9 salts solution.
 - Add 2 mL of sterile 2 M MgSO_4 .
 - Add 100 μL of sterile 1 M CaCl_2 .
 - Add 20 mL of sterile 20% glucose solution.
 - Adjust the final volume to 1 L with sterile ddH₂O.
- For M9 agar plates:
 - Add 15 g of agar to the 5X M9 salts solution and water before autoclaving.
 - After autoclaving, cool the medium to ~50-55°C.
 - Aseptically add the sterile MgSO_4 , CaCl_2 , and glucose solutions.

- Pour into sterile Petri dishes.

Protocol 2: Bacterial Growth Assay with Varying Ammonium Chloride Concentrations

This protocol outlines an experiment to assess the impact of different **ammonium chloride** concentrations on bacterial growth.

Materials:

- Bacterial strain of interest
- Nitrogen-free minimal medium base
- Sterile stock solution of **ammonium chloride** (e.g., 1 M)
- Spectrophotometer
- Sterile 96-well microplates
- Incubator shaker

Procedure:

- **Prepare Media:** Prepare a nitrogen-free minimal medium. Create a series of media with varying concentrations of **ammonium chloride** (e.g., 0 mM, 1 mM, 5 mM, 10 mM, 50 mM) by adding the appropriate volume of the sterile **ammonium chloride** stock solution.
- **Inoculum Preparation:** Grow an overnight culture of the bacterium in a suitable medium. Wash the cells twice with the nitrogen-free minimal medium to remove any residual nitrogen sources. Resuspend the cells in the nitrogen-free medium and adjust the optical density (OD₆₀₀) to a standardized value (e.g., 0.1).
- **Microplate Setup:** In a 96-well plate, add 180 µL of each medium concentration to triplicate wells. Add 20 µL of the prepared bacterial inoculum to each well. Include a blank control (medium only) for each concentration.

- **Incubation and Measurement:** Incubate the microplate in a shaker incubator at the optimal temperature for the bacterium. Measure the OD₆₀₀ at regular intervals (e.g., every hour) for 24-48 hours.
- **Data Analysis:** Subtract the blank OD₆₀₀ from the sample readings. Plot the average OD₆₀₀ against time to generate growth curves for each **ammonium chloride** concentration. Calculate the growth rate and maximum OD for each condition.

Experimental Workflow

The following diagram illustrates the general workflow for studying the effect of **ammonium chloride** on bacterial growth.

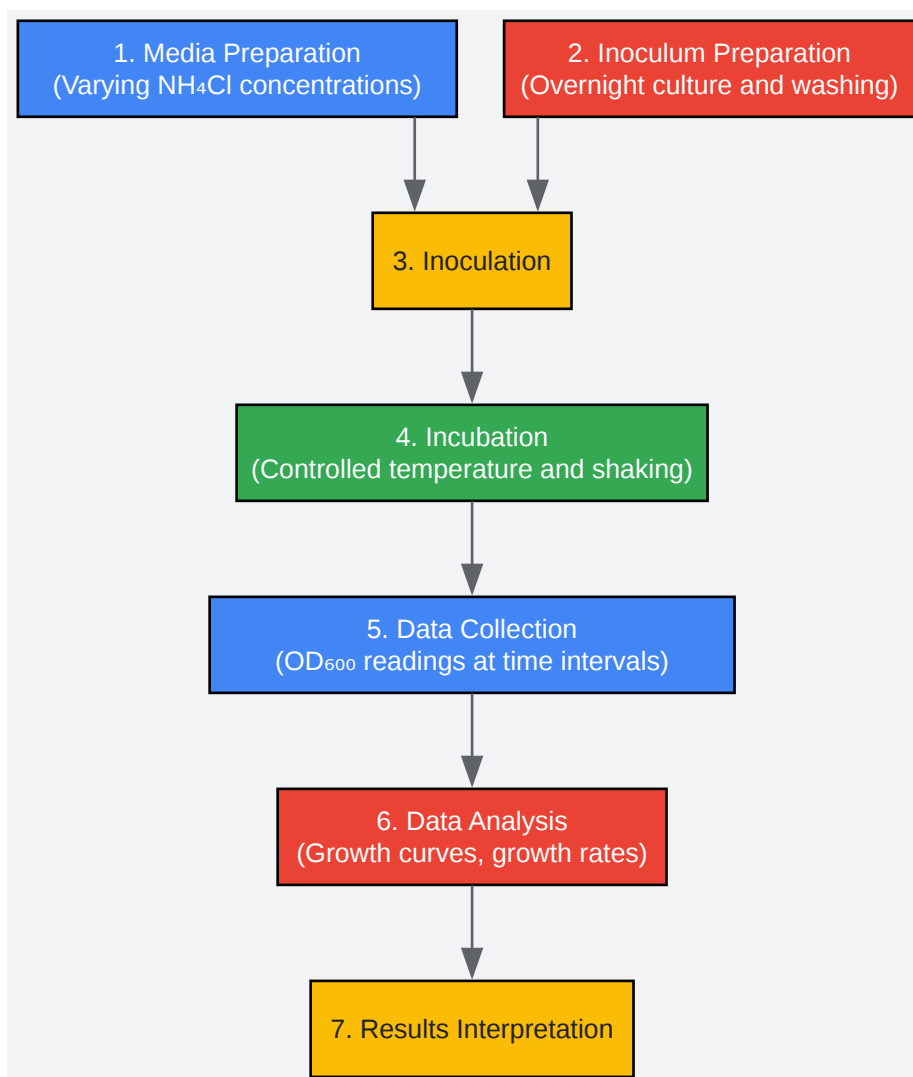

[Click to download full resolution via product page](#)

Workflow for Bacterial Growth Analysis

Conclusion

Ammonium chloride is a versatile and essential nitrogen source for the cultivation of a wide range of bacteria. Understanding its role in bacterial metabolism and the effects of its concentration on growth is critical for optimizing culture conditions in research, industrial, and drug development settings. The protocols and data presented here provide a foundation for the effective use of **ammonium chloride** in microbiological applications.

Need Custom Synthesis?

BenchChem offers custom synthesis for rare earth carbides and specific isotopic labeling.

Email: info@benchchem.com or [Request Quote Online](#).

References

- [1. How does NH₄Cl affect the growth of microorganisms? - Blog \[acefertilizer.com\]](#)
- [2. DOT Language | Graphviz \[graphviz.org\]](#)
- [3. quora.com \[quora.com\]](#)
- [4. tandfonline.com \[tandfonline.com\]](#)
- [5. researchgate.net \[researchgate.net\]](#)
- [6. Pathways and mechanisms for efficient nitrogen utilization in the high-temperature tolerant heterotrophic nitrifying bacterium *Aeribacillus pallidus* sp. GW-E - PMC \[pmc.ncbi.nlm.nih.gov\]](#)
- To cite this document: BenchChem. [Application Notes and Protocols: Ammonium Chloride in Bacterial Growth Media]. BenchChem, [2026]. [Online PDF]. Available at: [\[https://www.benchchem.com/product/b10774519/docs#application-notes-and-protocols-ammonium-chloride-in-bacterial-growth-media\]](https://www.benchchem.com/product/b10774519/docs#application-notes-and-protocols-ammonium-chloride-in-bacterial-growth-media)

Disclaimer & Data Validity:

The information provided in this document is for Research Use Only (RUO) and is strictly not intended for diagnostic or therapeutic procedures. While BenchChem strives to provide

accurate protocols, we make no warranties, express or implied, regarding the fitness of this product for every specific experimental setup.

Technical Support: The protocols provided are for reference purposes. Unsure if this reagent suits your experiment?

Need Industrial/Bulk Grade? [Request Custom Synthesis Quote](#)

BenchChem

Our mission is to be the trusted global source of essential and advanced chemicals, empowering scientists and researchers to drive progress in science and industry.

Contact

Address: 3281 E Guasti Rd

Ontario, CA 91761, United States

Phone: (601) 213-4426

Email: info@benchchem.com

[Contact our Ph.D. Support Team for a compatibility check](#)