

RapaLink-1 Technical Support Center: Managing Side Effects of Chronic Administration

Author: BenchChem Technical Support Team. **Date:** April 2026

Compound of Interest

Compound Name: RapaLink-1

Cat. No.: B10772746

[Get Quote](#)

For researchers, scientists, and drug development professionals utilizing the potent, third-generation mTOR inhibitor **RapaLink-1**, this technical support center provides essential guidance on managing potential side effects during chronic administration in preclinical experiments. This resource offers troubleshooting guides in a question-and-answer format, detailed experimental protocols, and visual aids to ensure the integrity and success of your research.

Frequently Asked Questions (FAQs) & Troubleshooting Guides

This section addresses common issues that may arise during the chronic administration of **RapaLink-1** in research animals.

Q1: We are observing significant weight loss in our mice treated with chronic **RapaLink-1**. Is this expected, and what can we do?

A1: Yes, weight loss is a potential side effect of chronic **RapaLink-1** administration. One study reported a significant decrease in the body weight of mice treated with 1 mg/kg of **RapaLink-1** three times a week for four weeks[1].

Troubleshooting Steps:

- **Confirm Dosing:** Double-check your dosing calculations and administration volume to ensure accuracy.
- **Monitor Food and Water Intake:** Quantify daily food and water consumption to determine if the weight loss is due to reduced appetite.
- **Body Condition Scoring:** Regularly assess the body condition of the animals to get a more comprehensive understanding of their health status beyond just body weight.
- **Consider Dose Reduction:** If the weight loss is severe and compromising animal welfare, consider reducing the dose or the frequency of administration. A study using 1.5 mg/kg of **RapaLink-1** every 5-7 days reported no significant weight changes compared to the vehicle group[2].
- **Dietary Supplementation:** If appetite is reduced, providing a more palatable or calorically dense diet may help mitigate weight loss. Consult with your facility's veterinarian for appropriate dietary options.

Q2: Our **RapaLink-1** treated animals are showing signs of hyperglycemia. How do we confirm and monitor this?

A2: Impaired glucose metabolism, leading to hyperglycemia, is a known side effect of mTOR inhibitors, and has been observed with chronic **RapaLink-1** administration[1].

Troubleshooting and Monitoring:

- **Baseline Glucose Measurement:** Always measure baseline blood glucose levels from a tail vein bleed before commencing chronic dosing.
- **Regular Glucose Monitoring:** Monitor blood glucose levels regularly (e.g., weekly) throughout the study.
- **Oral Glucose Tolerance Test (OGTT):** To definitively assess impaired glucose metabolism, perform an OGTT. A detailed protocol is provided in the "Experimental Protocols" section of

this guide. Markedly increased blood glucose levels during an OGTT are indicative of glucose intolerance[1].

Q3: We are concerned about potential liver toxicity with long-term **RapaLink-1** use. What are the signs and how can we monitor for it?

A3: Liver toxicity is a potential concern with chronic mTOR inhibitor administration. Studies have shown that chronic **RapaLink-1** treatment can lead to liver inflammation[1].

Monitoring for Hepatotoxicity:

- **Serum Biochemistry:** At the end of the study (or at interim time points), collect blood to perform a serum biochemistry panel. Key indicators of liver damage include elevated levels of alanine aminotransferase (ALT), aspartate aminotransferase (AST), and alkaline phosphatase (ALP)[3].
- **Histopathology:** Upon necropsy, collect liver tissue for histopathological analysis. Look for signs of inflammation, necrosis, and fibrosis. One study indicated that chronic **RapaLink-1** administration increased the expression of liver toxicity markers such as Timp1 and Col4A1[1]. A detailed protocol for tissue collection and processing is available in the "Experimental Protocols" section.

Q4: What are the potential effects of chronic **RapaLink-1** administration on the hematopoietic system?

A4: While specific data for **RapaLink-1** is limited, mTOR inhibitors as a class can have effects on the hematopoietic system. These can include mild, dose-dependent decreases in blood cell counts[4].

Monitoring Hematological Parameters:

- **Complete Blood Count (CBC):** Perform a CBC on whole blood collected at baseline and at the end of the study. Pay close attention to red blood cell counts, white blood cell counts (including differential counts), and platelet counts.
- **Interpretation:** Look for trends such as anemia (low red blood cells) or leukopenia (low white blood cells). Any significant changes from baseline or between treatment and control groups

should be noted.

Quantitative Data Summary

The following tables summarize quantitative data on the side effects of chronic **RapaLink-1** administration from preclinical studies.

Table 1: Effect of Chronic **RapaLink-1** Administration on Body Weight in Mice

Dosage Regimen	Species	Duration	Observation	Reference
1 mg/kg, 3x/week	Mice	4 weeks	Significant decrease in body weight compared to vehicle.	[1]
1.5 mg/kg, every 5-7 days	Mice	Not specified	Weight curve comparable to vehicle-treated animals.	[2]

Table 2: Metabolic Side Effects of Chronic **RapaLink-1** Administration in Mice

Dosage Regimen	Species	Duration	Parameter	Observation	Reference
1 mg/kg, 3x/week	Mice	4 weeks	Blood Glucose	Markedly increased during a Glucose Tolerance Test.	[1]

Table 3: Indicators of Liver Toxicity with Chronic **RapaLink-1** Administration in Mice

Dosage Regimen	Species	Duration	Biomarker	Observation	Reference
1 mg/kg, 3x/week	Mice	4 weeks	STAT3 phosphorylation	Robustly elevated in the liver.	[1]
1 mg/kg, 3x/week	Mice	4 weeks	Timp1 and Col4A1 mRNA	Increased levels in the liver.	[1]

Experimental Protocols

1. Oral Glucose Tolerance Test (OGTT) in Mice

This protocol is adapted from standard procedures to assess glucose metabolism in mice treated with mTOR inhibitors.

Materials:

- Glucose solution (20% w/v in sterile water or saline)
- Handheld glucometer and test strips
- Oral gavage needles
- Restraining device
- Scale

Procedure:

- Fasting: Fast mice for 6 hours prior to the test. Ensure free access to water.
- Baseline Glucose: At the end of the fasting period (time 0), obtain a baseline blood glucose reading from a small tail vein bleed.

- **Glucose Administration:** Immediately after the baseline reading, administer the 20% glucose solution via oral gavage at a dose of 2 g/kg body weight.
- **Blood Glucose Monitoring:** Collect blood from the tail vein and measure glucose levels at 15, 30, 60, 90, and 120 minutes post-glucose administration.
- **Data Analysis:** Plot the mean blood glucose concentration at each time point for each treatment group. Calculate the area under the curve (AUC) for each animal to quantify the overall glucose excursion.

2. Protocol for Serum Biochemistry and Liver Function Analysis

Procedure:

- **Blood Collection:** At the desired time point, collect whole blood via cardiac puncture or from the retro-orbital sinus into serum separator tubes.
- **Serum Separation:** Allow the blood to clot at room temperature for 30 minutes, then centrifuge at 2000 x g for 10 minutes at 4°C.
- **Sample Storage:** Collect the supernatant (serum) and store at -80°C until analysis.
- **Analysis:** Use an automated clinical chemistry analyzer to measure the levels of key liver enzymes (ALT, AST, ALP) and other relevant markers.

3. Necropsy and Histopathological Analysis of Liver and Kidney

Procedure:

- **Euthanasia and Necropsy:** Euthanize animals according to approved institutional protocols. Perform a gross necropsy, examining all major organs.
- **Tissue Collection:** Collect samples of the liver and kidneys. For the liver, take sections from multiple lobes.
- **Fixation:** Immediately place the collected tissues in 10% neutral buffered formalin for at least 24 hours.

- Processing and Staining: After fixation, tissues should be processed, embedded in paraffin, sectioned, and stained with hematoxylin and eosin (H&E).
- Microscopic Examination: A qualified pathologist should examine the slides for any histopathological changes, such as inflammation, cellular degeneration, necrosis, or fibrosis.

Visualizations

Signaling Pathways and Experimental Workflows

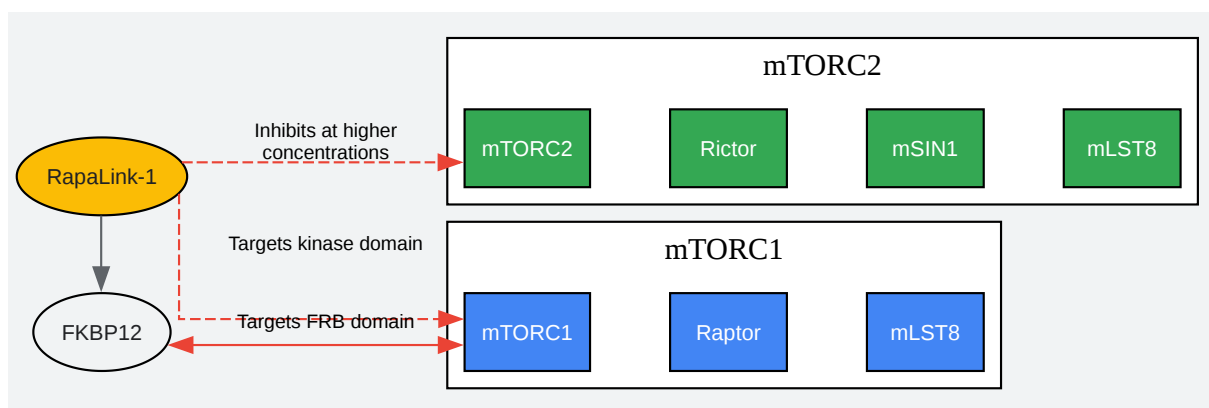

[Click to download full resolution via product page](#)

Caption: Mechanism of **RapaLink-1** Action.

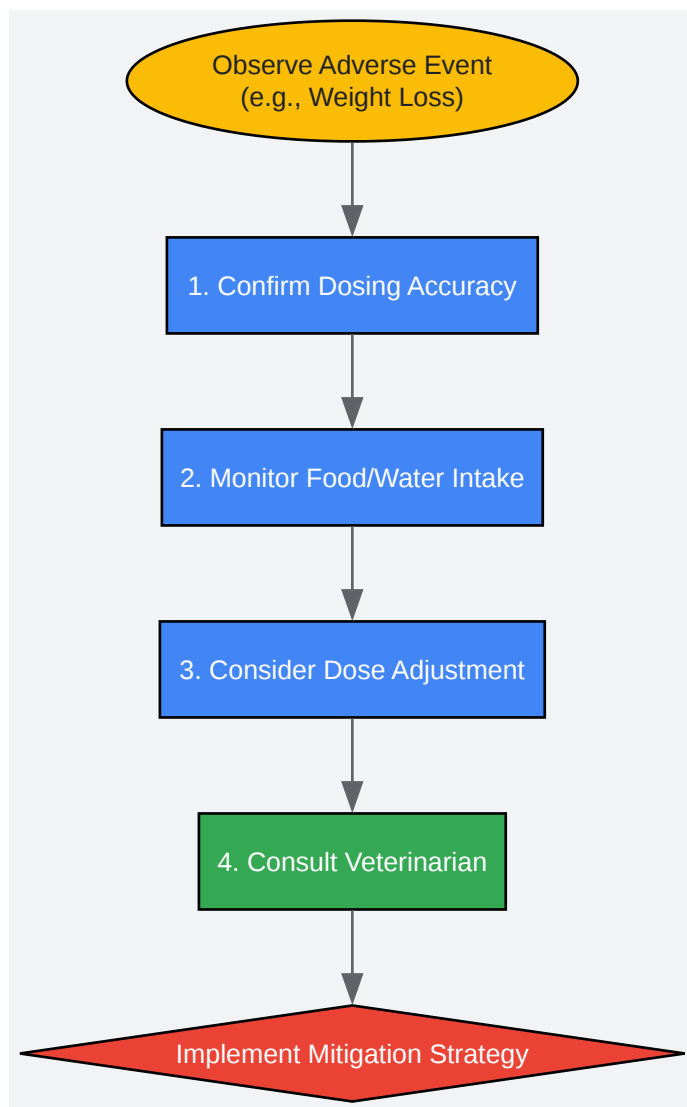

[Click to download full resolution via product page](#)

Caption: Troubleshooting Workflow for Adverse Events.

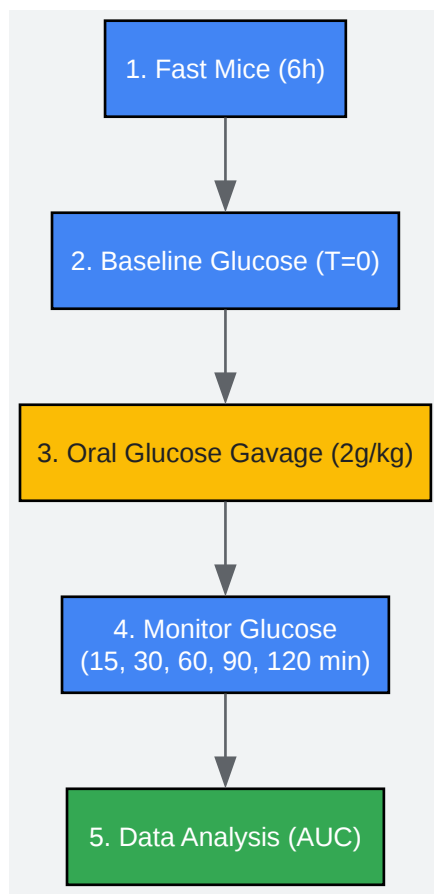

[Click to download full resolution via product page](#)

Caption: Experimental Workflow for an Oral Glucose Tolerance Test (OGTT).

Need Custom Synthesis?

BenchChem offers custom synthesis for rare earth carbides and specific isotopic labeling.

Email: info@benchchem.com or [Request Quote Online](#).

References

- [1. Brain-specific inhibition of mTORC1 eliminates side effects resulting from mTORC1 blockade in the periphery and reduces alcohol intake in mice - PMC \[pmc.ncbi.nlm.nih.gov\]](#)
- [2. researchgate.net \[researchgate.net\]](#)
- [3. researchgate.net \[researchgate.net\]](#)

- [4. mTOR Activation in Liver Tumors Is Associated with Metabolic Syndrome and Non-Alcoholic Steatohepatitis in Both Mouse Models and Humans - PMC \[pmc.ncbi.nlm.nih.gov\]](#)
- To cite this document: BenchChem. [RapaLink-1 Technical Support Center: Managing Side Effects of Chronic Administration]. BenchChem, [2026]. [Online PDF]. Available at: [<https://www.benchchem.com/product/b10772746/docs#rapalink-1-technical-support-center-managing-side-effects-of-chronic-administration>]

Disclaimer & Data Validity:

The information provided in this document is for Research Use Only (RUO) and is strictly not intended for diagnostic or therapeutic procedures. While BenchChem strives to provide accurate protocols, we make no warranties, express or implied, regarding the fitness of this product for every specific experimental setup.

Technical Support: The protocols provided are for reference purposes. Unsure if this reagent suits your experiment?

Need Industrial/Bulk Grade? [Request Custom Synthesis Quote](#)

BenchChem

Our mission is to be the trusted global source of essential and advanced chemicals, empowering scientists and researchers to drive progress in science and industry.

Contact

Address: 3281 E Guasti Rd
Ontario, CA 91761, United States
Phone: (601) 213-4426
Email: info@benchchem.com

[Contact our Ph.D. Support Team for a compatibility check](#)