

Application Notes and Protocols: UNC9994 in Mouse Models of Schizophrenia

Author: BenchChem Technical Support Team. **Date:** April 2026

Compound of Interest

Compound Name: UNC9994

Cat. No.: B10772701

[Get Quote](#)

For Researchers, Scientists, and Drug Development Professionals

These application notes provide detailed information and protocols for the use of **UNC9994**, a β -arrestin-biased dopamine D2 receptor (D2R) partial agonist, in preclinical mouse models of schizophrenia. This document is intended to guide researchers in designing and executing experiments to evaluate the therapeutic potential of **UNC9994** and similar compounds.

Introduction

UNC9994 is an analog of the atypical antipsychotic aripiprazole.[1][2] Unlike aripiprazole, **UNC9994** exhibits functional selectivity, acting as a partial agonist for D2R/ β -arrestin interactions without significantly affecting D2R-mediated Gai/o protein signaling.[1][2][3] This unique mechanism of action has shown promise in ameliorating positive, negative, and cognitive symptoms of schizophrenia in various preclinical models.[2][4] **UNC9994**'s antipsychotic-like activity is dependent on β -arrestin-2.[5]

Mechanism of Action

UNC9994's therapeutic potential lies in its ability to selectively modulate the β -arrestin signaling pathway downstream of the D2R. This is significant because traditional antipsychotics primarily target the G-protein signaling pathway, which is associated with a range of side effects. By favoring the β -arrestin pathway, **UNC9994** may offer a more targeted therapeutic approach with a potentially improved side-effect profile.[\[4\]](#)[\[5\]](#)[\[6\]](#)

The dopamine hypothesis of schizophrenia posits that hyperactivity of dopaminergic signaling in the striatum contributes to positive symptoms, while a deficit of dopamine in the prefrontal cortex is associated with negative and cognitive symptoms. **UNC9994** has been shown to act as a D2R- β arr2 antagonist in the striatum and a D2R- β arr2 agonist in the prefrontal cortex, suggesting it could simultaneously address both hyper- and hypo-dopaminergic states.[\[7\]](#)

Quantitative Data Summary

The following tables summarize the dosages and effects of **UNC9994** in various mouse models of schizophrenia.

Table 1: **UNC9994** Dosage and Administration in Mouse Models of Schizophrenia

Mouse Model	UNC9994 Dosage (mg/kg)	Administration Route	Combination Drug	Combination Dosage (mg/kg)	Reference
MK-801 Induced	0.25	Intraperitoneal (i.p.)	Haloperidol	0.15	[2] [3] [8]
Grin1 Knockdown (Grin1-KD)	0.25	Intraperitoneal (i.p.)	Haloperidol	0.15	[2] [3] [8]
Phencyclidine (PCP) Induced	2.0	Intraperitoneal (i.p.)	-	-	[5]
NR1-knockdown	0.5	Intraperitoneal (i.p.)	-	-	[9]

Table 2: Behavioral and Biochemical Effects of **UNC9994** in Schizophrenia Mouse Models

Mouse Model	UNC9994 Dosage (mg/kg)	Key Findings	Reference
MK-801 Induced & Grin1-KD	0.25 (with 0.15 Haloperidol)	Reduced hyperactivity, corrected prepulse inhibition (PPI) deficits, reversed rigid behavior in the Y-maze, and improved executive function in the Puzzle box test.[2] [8]	[2][8]
Phencyclidine (PCP) Induced	2.0	Markedly inhibited PCP-induced hyperlocomotion. This effect was abolished in β -arrestin-2 knockout mice.[5]	[5]
NR1-knockdown	0.5	Reduced hyperlocomotion.[9]	[9]
MK-801 Induced	0.25 (with 0.15 Haloperidol)	Reversed MK-801-induced effects on the phosphorylation of Akt at Serine-473 (pAkt-S473) in the prefrontal cortex and striatum.[3] [8]	[3][8]

Experimental Protocols

Mouse Models of Schizophrenia

Two primary types of mouse models are used to study schizophrenia-like phenotypes:

- Pharmacological Models: These models involve the acute administration of N-methyl-D-aspartate receptor (NMDAR) antagonists to induce a state that mimics aspects of schizophrenia.
 - MK-801 Induced Model: MK-801, a non-competitive NMDAR antagonist, is administered to induce hyperlocomotion and deficits in sensorimotor gating, reflecting positive and cognitive symptoms. A typical dose is 0.15 mg/kg administered intraperitoneally.[2][3][8]
 - Phencyclidine (PCP) Induced Model: PCP, another NMDAR antagonist, is used to induce hyperlocomotion. A common dosage is 6 mg/kg administered intraperitoneally.[5]
- Genetic Models: These models involve the genetic manipulation of components of the glutamatergic system to create a chronic hypofunctional NMDAR state.
 - Grin1 Knockdown (Grin1-KD) Mice: These mice have a significant reduction in the expression of the Grin1 gene, which encodes the essential NR1 subunit of the NMDA receptor. This results in a roughly 90% reduction in NMDAR levels and the exhibition of schizophrenia-like behaviors.[2][3][8]
 - NR1-knockdown Mice: Similar to Grin1-KD mice, these animals have reduced levels of the NR1 subunit, leading to persistent hypoglutamatergic conditions and hyperactivity.[9]

UNC9994 Administration

- Preparation: **UNC9994** is typically dissolved in a vehicle suitable for intraperitoneal injection. The specific vehicle should be reported in the experimental details.
- Administration: **UNC9994** is administered via intraperitoneal (i.p.) injection. The volume of injection should be consistent across all animals and adjusted for body weight.
- Timing: In pharmacological models, **UNC9994** is typically administered 30 minutes prior to the administration of the NMDAR antagonist (e.g., MK-801 or PCP).[5]

Behavioral Assays

- Open Field Test: This test is used to assess locomotor activity. Mice are placed in an open arena, and their movement is tracked for a specified period. **UNC9994** has been shown to

reduce the hyperlocomotion induced by NMDAR antagonists or genetic modifications.[2][8]
[9]

- Prepulse Inhibition (PPI) Test: PPI is a measure of sensorimotor gating, which is often deficient in individuals with schizophrenia. The test measures the ability of a weak prestimulus (prepulse) to inhibit the startle response to a subsequent strong stimulus (pulse). **UNC9994**, particularly in combination with haloperidol, has been shown to reverse PPI deficits.[2][8]
- Y-Maze Test: This test can be used to assess spatial memory and exploratory behavior. In the context of the cited studies, it was used to measure repetitive or rigid behavior.[2][8]
- Puzzle Box Test: This test is used to evaluate executive function and problem-solving abilities in mice.[2][8]

Biochemical Analysis

- Western Blotting: Following behavioral testing, brain regions of interest (e.g., prefrontal cortex and striatum) can be dissected for biochemical analysis. Western blotting can be used to measure the phosphorylation levels of key signaling proteins, such as Akt and GSK-3, which are downstream of the D2R signaling pathway.[1][3]

Visualizations

Signaling Pathway of **UNC9994** at the Dopamine D2 Receptor

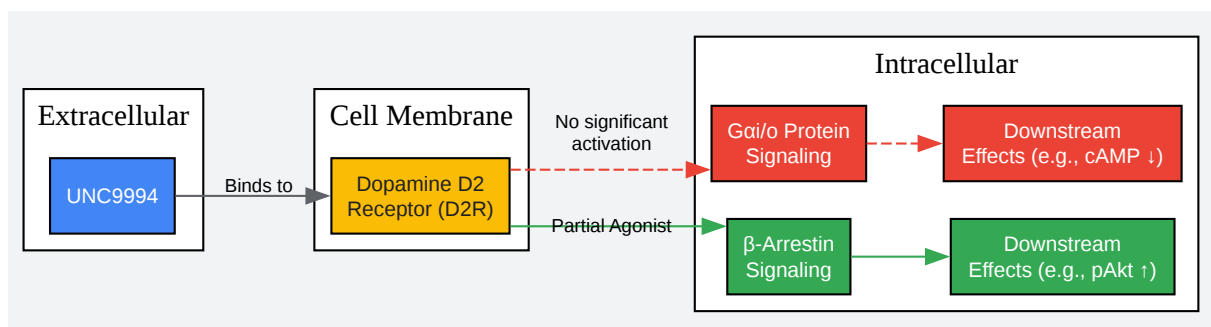

[Click to download full resolution via product page](#)

Caption: **UNC9994's** biased agonism at the D2R.

Experimental Workflow for Evaluating **UNC9994**

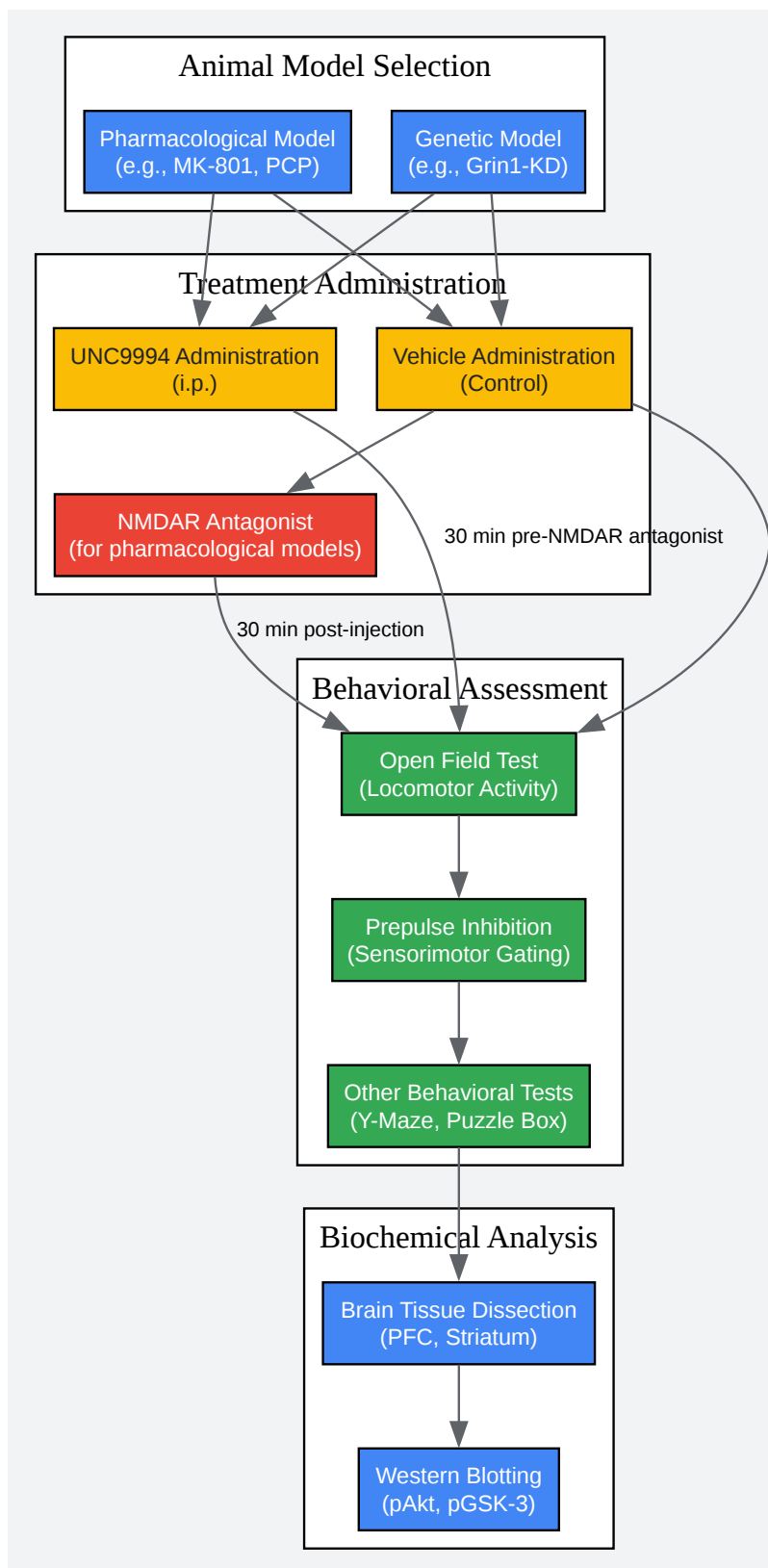

[Click to download full resolution via product page](#)

Caption: Workflow for **UNC9994** evaluation.

Need Custom Synthesis?

BenchChem offers custom synthesis for rare earth carbides and specific isotopic labeling.

Email: info@benchchem.com or [Request Quote Online](#).

References

- 1. Combination of Haloperidol With UNC9994, β -arrestin-Biased Analog of Aripiprazole, Ameliorates Schizophrenia-Related Phenotypes Induced by NMDAR Deficit in Mice - PMC [[pmc.ncbi.nlm.nih.gov](https://pubmed.ncbi.nlm.nih.gov)]
- 2. [biorxiv.org](https://www.biorxiv.org) [[biorxiv.org](https://www.biorxiv.org)]
- 3. Combination of Haloperidol With UNC9994, β -arrestin-Biased Analog of Aripiprazole, Ameliorates Schizophrenia-Related Phenotypes Induced by NMDAR Deficit in Mice - PubMed [pubmed.ncbi.nlm.nih.gov]
- 4. Effects of β -Arrestin-Biased Dopamine D2 Receptor Ligands on Schizophrenia-Like Behavior in Hypoglutamatergic Mice - PubMed [pubmed.ncbi.nlm.nih.gov]
- 5. [pnas.org](https://www.pnas.org) [[pnas.org](https://www.pnas.org)]
- 6. The Beta-Arrestin-Biased Dopamine D2 Receptor Ligand, UNC9994, Is a Partial Agonist at G-Protein-Mediated Potassium Channel Activation - PMC [[pmc.ncbi.nlm.nih.gov](https://pubmed.ncbi.nlm.nih.gov)]
- 7. New Concepts in Dopamine D2 Receptor Biased Signaling and Implications for Schizophrenia Therapy - PMC [[pmc.ncbi.nlm.nih.gov](https://pubmed.ncbi.nlm.nih.gov)]
- 8. academic.oup.com [academic.oup.com]
- 9. Effects of β -Arrestin-Biased Dopamine D2 Receptor Ligands on Schizophrenia-Like Behavior in Hypoglutamatergic Mice - PMC [[pmc.ncbi.nlm.nih.gov](https://pubmed.ncbi.nlm.nih.gov)]
- To cite this document: BenchChem. [Application Notes and Protocols: UNC9994 in Mouse Models of Schizophrenia]. BenchChem, [2026]. [Online PDF]. Available at: [<https://www.benchchem.com/product/b10772701/docs#application-notes-and-protocols-unc9994-in-mouse-models-of-schizophrenia>]

Disclaimer & Data Validity:

The information provided in this document is for Research Use Only (RUO) and is strictly not intended for diagnostic or therapeutic procedures. While BenchChem strives to provide accurate protocols, we make no warranties, express or implied, regarding the fitness of this product for every specific experimental setup.

Technical Support: The protocols provided are for reference purposes. Unsure if this reagent suits your experiment?

Need Industrial/Bulk Grade? [Request Custom Synthesis Quote](#)

BenchChem

Our mission is to be the trusted global source of essential and advanced chemicals, empowering scientists and researchers to drive progress in science and industry.

Contact

Address: 3281 E Guasti Rd
Ontario, CA 91761, United States
Phone: (601) 213-4426
Email: info@benchchem.com

[Contact our Ph.D. Support Team for a compatibility check](#)