

# Application Notes and Protocols: Prostate Cancer Organoid Assays with RapaLink-1

**Author:** BenchChem Technical Support Team. **Date:** April 2026

## Compound of Interest

Compound Name: RapaLink-1

Cat. No.: B10772746

[Get Quote](#)

Audience: Researchers, scientists, and drug development professionals.

## Introduction

Prostate cancer (PCa) is a leading cause of cancer-related mortality in men, characterized by significant heterogeneity.[1][2] This complexity presents challenges for developing effective therapies, as preclinical models often fail to recapitulate the features of patient tumors.[1][3] Patient-derived organoids (PDOs) have emerged as a powerful preclinical model, creating three-dimensional in vitro cultures that preserve the genetic, phenotypic, and histological characteristics of the original tumor.[1][3][4] This technology enables more accurate drug sensitivity testing and personalized medicine approaches.[4][5]

The PI3K/Akt/mTOR signaling pathway is frequently dysregulated in advanced and castration-resistant prostate cancer (CRPC).[2][6] The mammalian target of rapamycin (mTOR) is a serine/threonine kinase that exists in two distinct complexes, mTORC1 and mTORC2, which regulate cell growth, proliferation, and metabolism.[7] While first-generation mTOR inhibitors (rapalogs) showed limited clinical efficacy due to incomplete mTORC1 inhibition, newer generations of inhibitors have been developed.[6][8]

**RapaLink-1** is a third-generation, bivalent mTOR inhibitor that combines the durable effect of rapamycin with dual mTORC1 and mTORC2 kinase inhibition.[6][9] It achieves this by linking a rapamycin-like molecule, which binds to FKBP12, with an mTOR kinase inhibitor (TORKi).[9] This unique structure allows for potent and targeted inhibition of both mTOR complexes, overcoming resistance observed with earlier-generation inhibitors.[7][9] Studies have demonstrated that **RapaLink-1** effectively reduces the viability of prostate cancer PDX-derived organoids and inhibits tumor growth, highlighting its potential as a therapeutic agent for advanced PCa.[6][8]

These application notes provide detailed protocols for utilizing **RapaLink-1** in drug sensitivity assays with prostate cancer organoids.

## Mechanism of Action of RapaLink-1

**RapaLink-1** functions as a molecular glue, bridging the FKBP12 protein and the FRB domain of mTOR to potently inhibit kinase activity.[9][10] It is a bivalent compound that consists of a rapamycin analog linked to a second-generation mTOR kinase inhibitor (MLN0128).[9] One part of **RapaLink-1** binds to the highly abundant intracellular protein FKBP12; this complex then targets the FRB domain on mTOR, allosterically inhibiting mTORC1 activity.[9][11][12] The TORKi moiety of **RapaLink-1** simultaneously targets the ATP-binding site in the mTOR kinase domain, leading to the inhibition of both mTORC1 and mTORC2.[6][9] This dual mechanism allows **RapaLink-1** to block downstream effectors of both complexes, including the phosphorylation of S6 and ULK1 (by mTORC1) and Akt (by mTORC2), more effectively than rapalogs alone.[6][8]

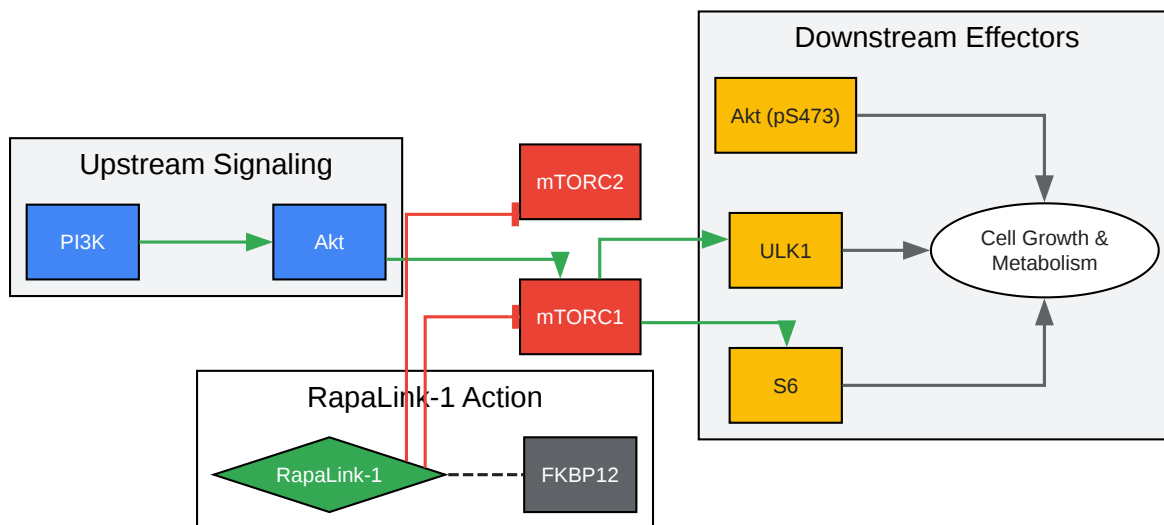

[Click to download full resolution via product page](#)

**Caption:** RapaLink-1 inhibits both mTORC1 and mTORC2 signaling pathways.

## Data Presentation

### Table 1: In Vitro Efficacy of RapaLink-1 in Prostate Cancer PDX-Derived Organoids

| Organoid Model | Drug       | IC <sub>50</sub> Value (μM) | Effective Concentration (μM) | Treatment Duration (hours) | Key Finding  |
|----------------|------------|-----------------------------|------------------------------|----------------------------|--|
| LAPC9          | RapaLink-1 | 0.0046                      | 0.01 - 10                    | 48                         | Significantly reduced organoid viability.[6][8]                  |
| BM18           | RapaLink-1 | 0.0003                      | 0.01 - 10                    | 48                         | Significantly reduced organoid viability.[8]                     |
| LAPC9          | Rapamycin  | > 1                         | 1                            | 48                         | Only significantly effective at 1 μM.[8]                         |
| LAPC9          | Everolimus | Not effective               | Up to 10                     | 48                         | Could not reduce organoid viability at tested concentrations.[8] |

**Table 2: Summary of RapaLink-1 Effects on mTOR Pathway Phosphorylation in PDX Organoids[8]**

| Organoid Model | Treatment (0.1 $\mu$ M, 48h) | p-S6 (Ser240/244) | p-ULK1 (Ser757)     | p-Akt (Ser473) |
|----------------|------------------------------|-------------------|---------------------|----------------|
| LAPC9          | RapaLink-1                   | Abolished         | Efficiently Blocked | Abolished      |
| LAPC9          | Rapamycin                    | Abolished         | Little to no effect | No effect      |
| LAPC9          | Everolimus                   | Abolished         | Little to no effect | No effect      |
| BM18           | RapaLink-1                   | Abolished         | Efficiently Blocked | Abolished      |
| BM18           | Rapamycin                    | Abolished         | Little to no effect | No effect      |
| BM18           | Everolimus                   | Abolished         | Little to no effect | No effect      |

## Experimental Workflow for Drug Sensitivity Assay

The overall workflow involves establishing robust organoid cultures from patient or PDX tissue, dissociating and seeding these organoids into microplates, treating them with a dilution series of **RapaLink-1**, and finally assessing cell viability to determine the dose-response relationship.

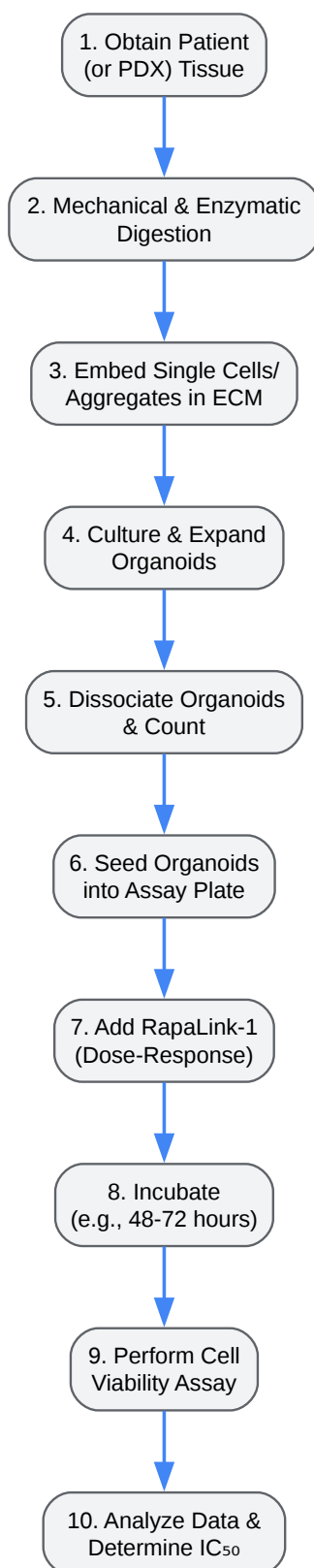

[Click to download full resolution via product page](#)

**Caption:** Workflow for prostate cancer organoid drug sensitivity testing.

## Detailed Experimental Protocols

### Protocol 1: Establishment and Culture of Prostate Cancer Organoids

This protocol is adapted from established methods for generating organoids from patient-derived xenografts or patient tumor tissue.[\[4\]](#)[\[13\]](#)[\[14\]](#)

#### Materials:

- Prostate cancer tissue (from surgical resection or PDX model)
- Advanced DMEM/F12
- HEPES, Glutamax, Penicillin-Streptomycin
- Growth factors (e.g., R-spondin 1, Noggin, EGF, FGF10)
- DHT (dihydrotestosterone)
- ROCK inhibitor (Y-27632)
- Collagenase Type II
- TrypLE Express
- Reduced Growth Factor Basement Membrane Extract (BME), Type 2 or Matrigel
- Sterile PBS and cell culture plates/flasks

#### Procedure:

- Tissue Preparation: Place fresh tissue in a sterile petri dish on ice. Wash thoroughly with cold PBS supplemented with Penicillin-Streptomycin.
- Mechanical Dissociation: Mince the tissue into small fragments (<1 mm<sup>3</sup>) using sterile scalpels.

- **Enzymatic Digestion:** Transfer the minced tissue to a tube containing Collagenase Type II in culture medium. Incubate at 37°C for 30-60 minutes with agitation until the tissue is disaggregated.
- **Cell Collection:** Neutralize the enzyme with excess culture medium, pass the suspension through a 100 µm cell strainer, and centrifuge at 300 x g for 5 minutes to pellet the cells.
- **Embedding in ECM:** Resuspend the cell pellet in a cold solution of BME/Matrigel. Dispense 40-50 µL droplets into the center of pre-warmed culture plate wells.
- **Solidification:** Incubate the plate at 37°C for 15-30 minutes to allow the droplets to solidify. [\[13\]](#)
- **Culture:** Gently add pre-warmed prostate organoid culture medium supplemented with DHT and ROCK inhibitor (Y-27632) to each well.
- **Maintenance:** Culture the organoids at 37°C and 5% CO<sub>2</sub>. Refresh the medium every 2-3 days. Organoids should become visible within a few days and can be passaged every 1-2 weeks. [\[14\]](#)
- **Passaging:** To passage, mechanically disrupt the ECM domes and collect the organoids. Incubate with TrypLE at 37°C to dissociate into smaller clumps or single cells. Wash, pellet, and re-embed in fresh ECM as described above.

## Protocol 2: RapaLink-1 Drug Sensitivity Assay

This protocol outlines a drug sensitivity screen in a 384-well plate format using an ATP-based viability assay. [\[15\]](#)[\[16\]](#)[\[17\]](#)

Materials:

- Established prostate cancer organoid cultures
- **RapaLink-1** (lyophilized powder) [\[7\]](#)
- DMSO
- Organoid culture medium

- 384-well flat clear-bottom, opaque-walled assay plates
- CellTiter-Glo® 3D Cell Viability Assay kit or similar ATP-based assay
- Luminometer plate reader

#### Procedure:

- **RapaLink-1** Preparation: Reconstitute lyophilized **RapaLink-1** in DMSO to create a high-concentration stock solution (e.g., 10 mM).[7] Store at -80°C. Prepare serial dilutions in organoid culture medium to create a dose-response range (e.g., 0.1 nM to 10 μM). The final DMSO concentration in all wells should be kept constant and low ( $\leq 0.1\%$ ).[18]
- Organoid Preparation: Harvest mature organoids and dissociate them into small, uniform clumps using TrypLE and gentle pipetting. Count the organoids or create a single-cell suspension for accurate counting.
- Seeding: Dilute the organoid suspension in culture medium (can be supplemented with 2-4% ECM to prevent clumping) to the desired seeding density.[16] Dispense 40 μL of the organoid suspension into each well of a 384-well plate. Leave perimeter wells with medium only to reduce edge effects.
- Incubation: Allow organoids to settle and recover for 24-48 hours in the incubator (37°C, 5% CO<sub>2</sub>).[6][8]
- Drug Treatment: Add 10 μL of the prepared **RapaLink-1** dilutions (or vehicle control, e.g., 0.1% DMSO) to the appropriate wells. Include positive controls for cell death if desired (e.g., Staurosporine).[15]
- Incubation: Return the plate to the incubator for the desired treatment period (e.g., 48-72 hours).[6][8][18]
- Viability Assay (CellTiter-Glo):
  - Remove the plate from the incubator and allow it to equilibrate to room temperature for 30 minutes.[17]

- Add 25-40  $\mu$ L of CellTiter-Glo reagent to each well.
- Place the plate on an orbital shaker for 5 minutes to induce cell lysis.[17]
- Incubate at room temperature for an additional 25 minutes to stabilize the luminescent signal.[17]
- Data Acquisition: Measure the luminescence of each well using a plate reader.
- Data Analysis: Subtract the background luminescence (media-only wells). Normalize the data to the vehicle-treated control wells (representing 100% viability). Plot the normalized viability against the log of **RapaLink-1** concentration and use a non-linear regression model to calculate the IC<sub>50</sub> value.

### Need Custom Synthesis?

BenchChem offers custom synthesis for rare earth carbides and specific isotopic labeling.

Email: [info@benchchem.com](mailto:info@benchchem.com) or [Request Quote Online](#).

## References

- [1. Establishment and Maintenance of Patient-derived Prostate Cancer Organoids: A Detailed Experimental Protocol \[jove.com\]](#)
- [2. Dual-mTOR Inhibitor Rapalink-1 Reduces Prostate Cancer Patient-Derived Xenograft Growth and Alters Tumor Heterogeneity - PubMed \[pubmed.ncbi.nlm.nih.gov\]](#)
- [3. scispace.com \[scispace.com\]](#)
- [4. mdpi.com \[mdpi.com\]](#)
- [5. Drug Sensitivity Assays of Human Cancer Organoid Cultures | Springer Nature Experiments \[experiments.springernature.com\]](#)
- [6. Frontiers | Dual-mTOR Inhibitor Rapalink-1 Reduces Prostate Cancer Patient-Derived Xenograft Growth and Alters Tumor Heterogeneity \[frontiersin.org\]](#)
- [7. RapaLink-1 | Cell Signaling Technology \[cellsignal.com\]](#)
- [8. Dual-mTOR Inhibitor Rapalink-1 Reduces Prostate Cancer Patient-Derived Xenograft Growth and Alters Tumor Heterogeneity - PMC \[pmc.ncbi.nlm.nih.gov\]](#)

- [9. medchemexpress.com \[medchemexpress.com\]](https://www.medchemexpress.com)
- [10. Molecular glue - Wikipedia \[en.wikipedia.org\]](https://en.wikipedia.org)
- [11. FKBP12\\_Rapamycin \[collab.its.virginia.edu\]](https://collab.its.virginia.edu)
- [12. researchgate.net \[researchgate.net\]](https://www.researchgate.net)
- [13. ccr.cancer.gov \[ccr.cancer.gov\]](https://ccr.cancer.gov)
- [14. Organoid culture systems for prostate epithelial tissue and prostate cancer tissue - PMC \[pmc.ncbi.nlm.nih.gov\]](#)
- [15. Drug Sensitivity Assays of Human Cancer Organoid Cultures - PMC \[pmc.ncbi.nlm.nih.gov\]](#)
- [16. protocols.io \[protocols.io\]](https://www.protocols.io)
- [17. A Method for Drug Sensitivity Activity Testing of Organoids \[absin.net\]](https://absin.net)
- [18. Short-term organoid culture for drug sensitivity testing of high-grade serous carcinoma - PMC \[pmc.ncbi.nlm.nih.gov\]](#)
- To cite this document: BenchChem. [Application Notes and Protocols: Prostate Cancer Organoid Assays with RapaLink-1]. BenchChem, [2026]. [Online PDF]. Available at: [\[https://www.benchchem.com/product/b10772746/docs#application-notes-and-protocols-prostate-cancer-organoid-assays-with-rapalink-1\]](https://www.benchchem.com/product/b10772746/docs#application-notes-and-protocols-prostate-cancer-organoid-assays-with-rapalink-1)

---

### Disclaimer & Data Validity:

The information provided in this document is for Research Use Only (RUO) and is strictly not intended for diagnostic or therapeutic procedures. While BenchChem strives to provide accurate protocols, we make no warranties, express or implied, regarding the fitness of this product for every specific experimental setup.

**Technical Support:** The protocols provided are for reference purposes. Unsure if this reagent suits your experiment?

**Need Industrial/Bulk Grade?** [Request Custom Synthesis Quote](#)

# BenchChem

Our mission is to be the trusted global source of essential and advanced chemicals, empowering scientists and researchers to drive progress in science and industry.

## Contact

Address: 3281 E Guasti Rd

Ontario, CA 91761, United States

Phone: (601) 213-4426

Email: [info@benchchem.com](mailto:info@benchchem.com)

[Contact our Ph.D. Support Team for a compatibility check](#)