

Foundational Research on ER α Partial Agonists: A Technical Guide

Author: BenchChem Technical Support Team. **Date:** April 2026

Compound of Interest

Compound Name: CM-352
Cat. No.: B10771573

[Get Quote](#)

For Researchers, Scientists, and Drug Development Professionals

This technical guide provides an in-depth overview of the foundational research on Estrogen Receptor Alpha (ER α) partial agonists. It is designed to serve as a comprehensive resource for researchers, scientists, and professionals involved in drug development, offering detailed experimental methodologies, a structured presentation of quantitative data, and visualizations of key biological pathways and experimental procedures.

Core Concepts in ER α Partial Agonism

Estrogen Receptor α (ER α) is a ligand-activated transcription factor that plays a crucial role in various physiological processes. ER α partial agonists are a class of ligands that bind to ER α and elicit a response that is intermediate between that of a full agonist (like estradiol) and a full antagonist (like fulvestrant). The unique activity of partial agonists stems from their ability to induce a specific conformation of the ER α protein, leading to differential recruitment of co-regulator proteins (co-activators and co-repressors) to the receptor-ligand complex. This results in tissue-specific and gene-specific regulation of transcription.

The mechanism of ER α partial agonism is intricately linked to the two transcriptional activation functions (AFs) of the receptor: the ligand-independent AF-1 in the N-terminal domain and the

ligand-dependent AF-2 in the ligand-binding domain (LBD). The conformation of Helix 12 in the LBD is particularly critical; agonists stabilize an active conformation that facilitates co-activator binding to the AF-2 domain, while antagonists induce a conformation that blocks this interaction. Partial agonists induce a conformation that allows for a limited or altered set of co-regulator interactions, leading to a blended agonist/antagonist profile.

Key Signaling Pathways

ER α partial agonists modulate both genomic and non-genomic signaling pathways.

Genomic Signaling Pathway

The classical genomic pathway involves the binding of the ER α -ligand complex to Estrogen Response Elements (EREs) in the promoter regions of target genes, thereby regulating their transcription. Partial agonists can lead to a unique pattern of gene expression compared to full agonists or antagonists.

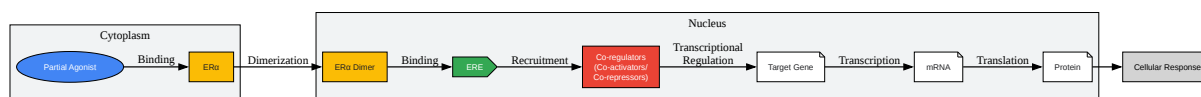

[Click to download full resolution via product page](#)

ER α Genomic Signaling Pathway

Non-Genomic Signaling Pathways

ER α can also mediate rapid, non-genomic effects by associating with signaling molecules in the cytoplasm, such as Src, and activating downstream cascades like the MAPK/ERK and PI3K/AKT pathways. These pathways can, in turn, influence gene expression and cell proliferation.

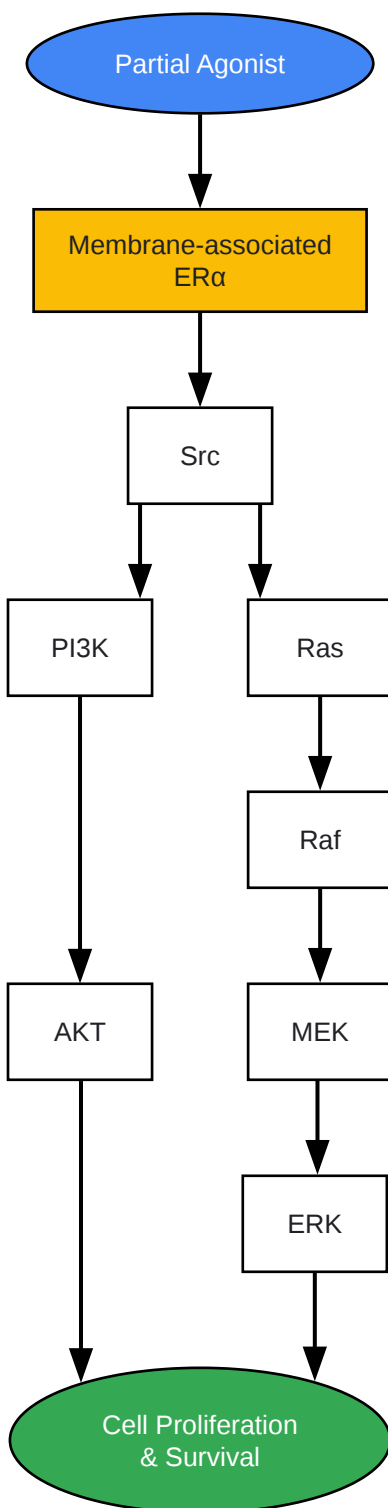

[Click to download full resolution via product page](#)

ERα Non-Genomic Signaling Pathways

Quantitative Data Presentation

The following tables summarize the quantitative data for representative ER α partial agonists, including their binding affinity, potency, and efficacy in various assays.

Table 1: ER α Binding Affinity of Partial Agonists

Compound	Assay Type	IC50 (nM)	Ki (nM)	Relative Binding Affinity (RBA, %)	Reference
Estradiol (E2)	Competitive Binding	1.5	0.1	100	[1]
Tamoxifen	Competitive Binding	2.5	0.2	60	[1]
Raloxifene	Competitive Binding	3.0	0.25	50	[1]
Genistein	Competitive Binding	50	4.2	3	[2]
ShERPA 30a	Fluorescence Polarization	-	-	123 (vs Raloxifene)	[3]

Table 2: Potency and Efficacy of ER α Partial Agonists in ERE-Luciferase Reporter Assay (MCF-7 cells)

Compound	EC50 (nM)	E _{max} (% of E2)	Reference
Estradiol (E2)	0.1	100	[3]
Tamoxifen	10	20-40	[3]
Raloxifene	15	<10	[3]
Genistein	5	80-100	[2]
ShERPA 14a	2.6	~100	[3]
ShERPA 30a	0.8	50.6	[3]

Experimental Protocols

Detailed methodologies for key experiments cited in the study of ER α partial agonists are provided below.

ER α Competitive Binding Assay

This assay determines the relative binding affinity of a test compound for ER α by measuring its ability to compete with a radiolabeled ligand (e.g., [3H]-Estradiol) for binding to the receptor.

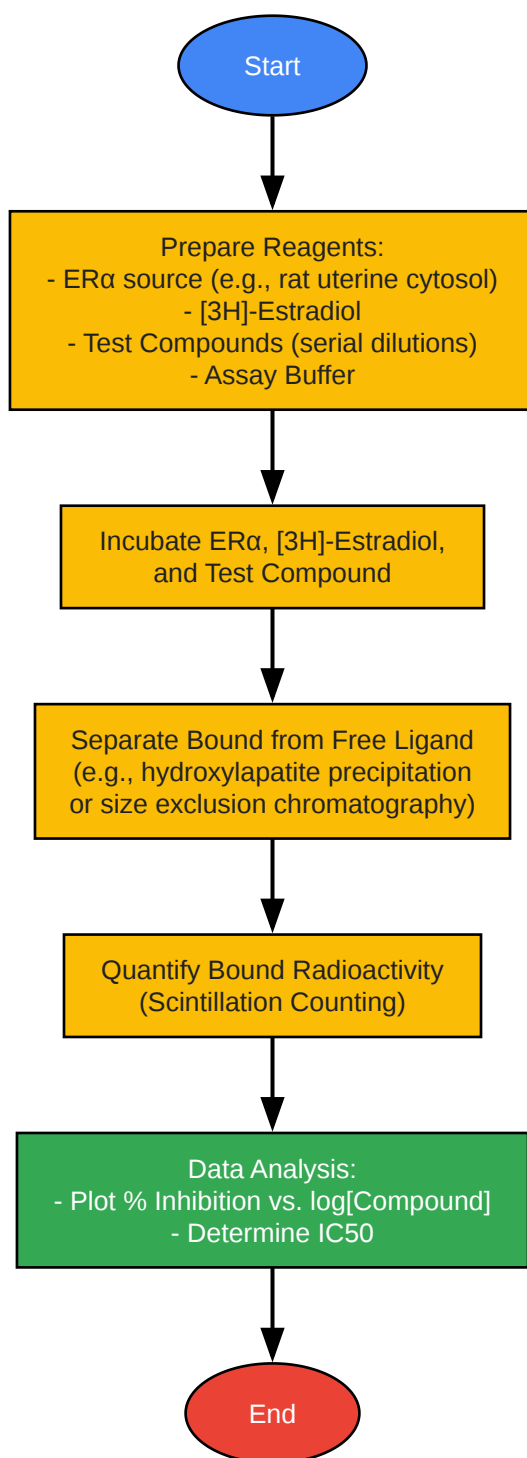

[Click to download full resolution via product page](#)

Competitive Binding Assay Workflow

Protocol:

- Preparation of ER α Source: Prepare cytosol from rat uteri or use purified recombinant ER α .
- Assay Setup: In assay tubes, combine the ER α preparation, a fixed concentration of [3H]-Estradiol, and varying concentrations of the test compound or unlabeled estradiol (for standard curve).
- Incubation: Incubate the mixture at 4°C for 18-24 hours to reach equilibrium.
- Separation of Bound and Free Ligand: Add a slurry of hydroxylapatite to each tube, incubate, and then centrifuge to pellet the hydroxylapatite with the bound receptor-ligand complex.
- Washing: Wash the pellet to remove unbound radioligand.
- Quantification: Resuspend the pellet in ethanol and transfer to a scintillation vial with scintillation cocktail. Measure the radioactivity using a scintillation counter.
- Data Analysis: Plot the percentage of specific binding against the logarithm of the competitor concentration. The IC50 value (the concentration of the test compound that inhibits 50% of the specific binding of the radioligand) is determined by non-linear regression analysis.

ERE-Luciferase Reporter Gene Assay

This cell-based assay measures the ability of a compound to activate ER α -mediated transcription from an ERE-containing promoter linked to a luciferase reporter gene.

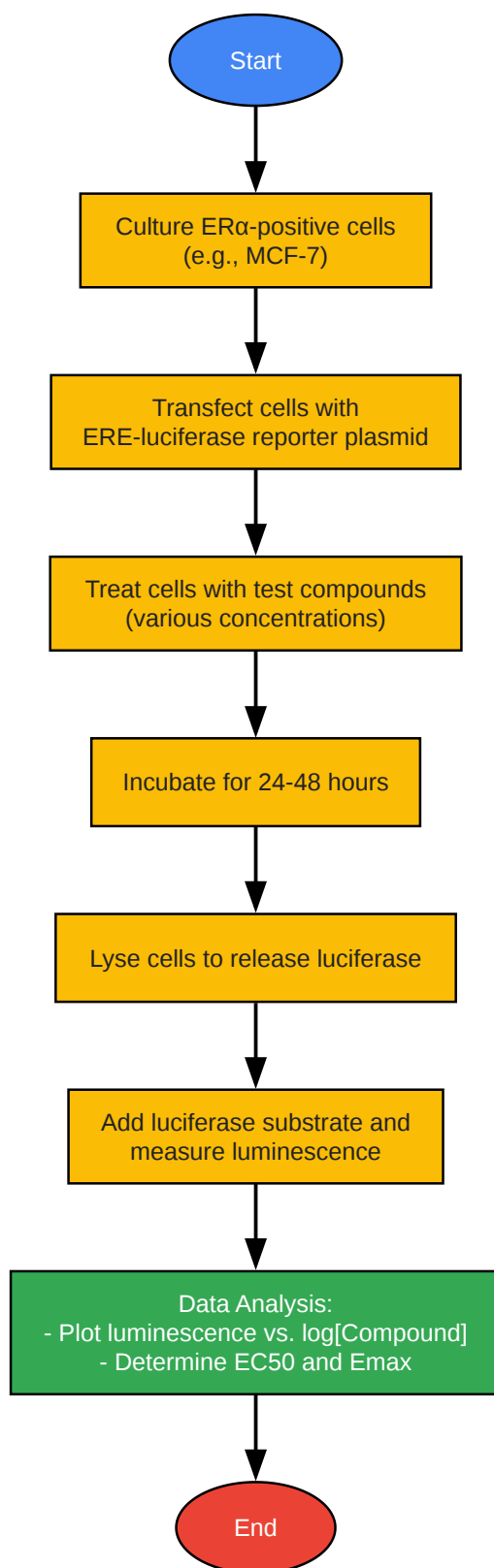

[Click to download full resolution via product page](#)

ERE-Luciferase Assay Workflow

Protocol:

- **Cell Culture and Transfection:** Culture ER α -positive cells (e.g., MCF-7) and transfect them with a plasmid containing an ERE-driven luciferase reporter gene. A co-transfection with a control plasmid (e.g., Renilla luciferase) is often performed for normalization.
- **Compound Treatment:** After transfection, treat the cells with various concentrations of the test compound, a full agonist (e.g., estradiol) as a positive control, and a vehicle control.
- **Incubation:** Incubate the cells for 24-48 hours to allow for gene expression.
- **Cell Lysis:** Lyse the cells using a suitable lysis buffer.
- **Luciferase Assay:** Add luciferase assay reagent containing the substrate (luciferin) to the cell lysates and measure the resulting luminescence using a luminometer. If a dual-luciferase system is used, subsequently add the substrate for the normalization reporter.
- **Data Analysis:** Normalize the firefly luciferase activity to the control reporter activity. Plot the normalized luciferase activity against the logarithm of the compound concentration. Determine the EC50 (the concentration that produces 50% of the maximal response) and Emax (the maximal response) from the dose-response curve.

ER α Co-regulator Recruitment Assay

This assay measures the ability of a ligand to promote or inhibit the interaction between ER α and specific co-regulator peptides. A common format is a fluorescence resonance energy transfer (FRET)-based assay.

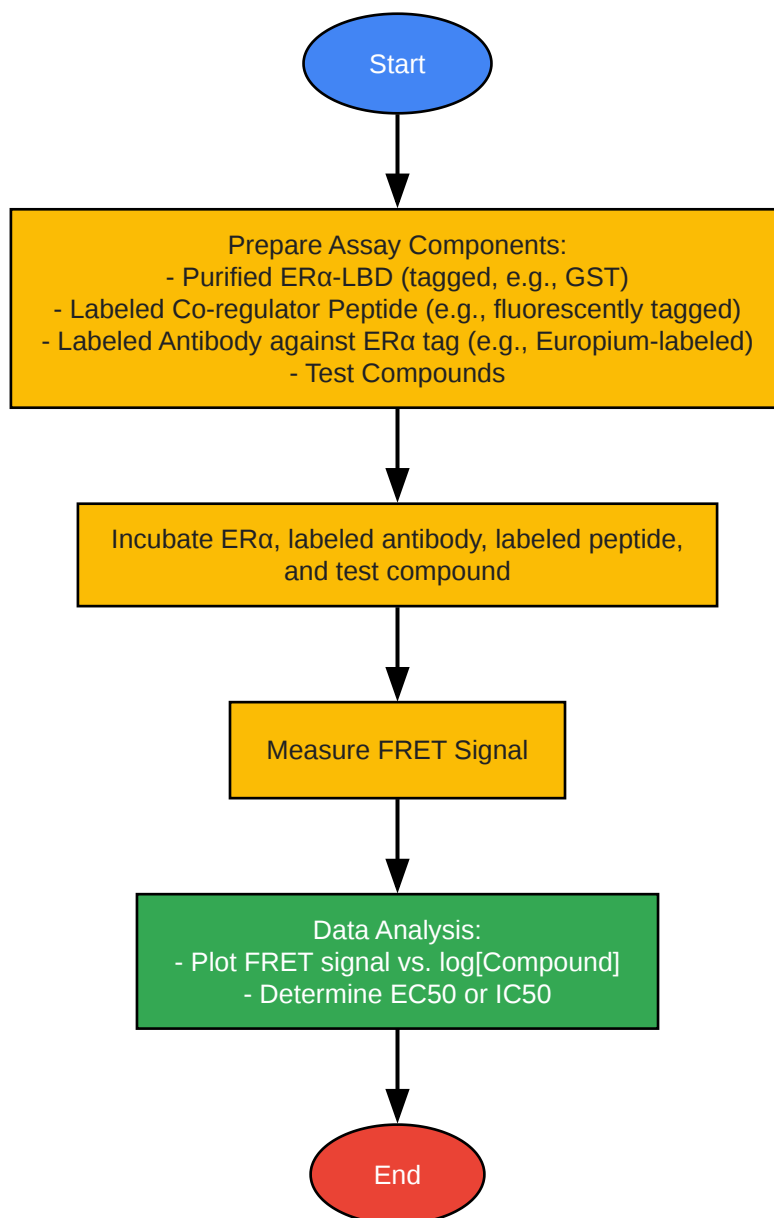

[Click to download full resolution via product page](#)

Co-regulator Recruitment Assay Workflow

Protocol:

- Reagent Preparation: Use purified, tagged ERα LBD (e.g., GST-ERα-LBD), a fluorescently labeled peptide corresponding to the nuclear receptor interaction domain of a co-regulator (e.g., SRC-1), and a FRET donor-labeled antibody that binds to the ERα tag (e.g., Europium-labeled anti-GST antibody).

- **Assay Setup:** In a microplate, combine the ER α -LBD, the labeled co-regulator peptide, the labeled antibody, and various concentrations of the test compound.
- **Incubation:** Incubate the mixture at room temperature to allow for binding to reach equilibrium.
- **FRET Measurement:** Excite the FRET donor and measure the emission from the FRET acceptor. An increased FRET signal indicates recruitment of the co-regulator peptide to the ER α -LBD.
- **Data Analysis:** For agonists, plot the FRET signal against the logarithm of the compound concentration to determine the EC50 for co-regulator recruitment. For antagonists, the assay is performed in the presence of a fixed concentration of an agonist, and the IC50 for the inhibition of agonist-induced recruitment is determined.

This technical guide provides a foundational understanding of ER α partial agonists, their mechanisms of action, and the experimental approaches used for their characterization. The provided data and protocols should serve as a valuable resource for the design and interpretation of studies in this important area of drug discovery and development.

Need Custom Synthesis?

BenchChem offers custom synthesis for rare earth carbides and specific isotopic labeling.

Email: info@benchchem.com or [Request Quote Online](#).

References

- [1. Structure-Based Understanding of Binding Affinity and Mode of Estrogen Receptor \$\alpha\$ Agonists and Antagonists - PMC \[pmc.ncbi.nlm.nih.gov\]](#)
- [2. Exploration of Dimensions of Estrogen Potency: PARSING LIGAND BINDING AND COACTIVATOR BINDING AFFINITIES - PMC \[pmc.ncbi.nlm.nih.gov\]](#)
- [3. Selective human Estrogen Receptor Partial Agonists \(ShERPAs\) for Tamoxifen-Resistant Breast Cancer - PMC \[pmc.ncbi.nlm.nih.gov\]](#)
- [To cite this document: BenchChem. \[Foundational Research on ER \$\alpha\$ Partial Agonists: A Technical Guide\]. BenchChem, \[2026\]. \[Online PDF\]. Available at:](#)

[<https://www.benchchem.com/product/b10771573/docs#foundational-research-on-er-partial-agonists-a-technical-guide>]

Disclaimer & Data Validity:

The information provided in this document is for Research Use Only (RUO) and is strictly not intended for diagnostic or therapeutic procedures. While BenchChem strives to provide accurate protocols, we make no warranties, express or implied, regarding the fitness of this product for every specific experimental setup.

Technical Support: The protocols provided are for reference purposes. Unsure if this reagent suits your experiment?

Need Industrial/Bulk Grade? [Request Custom Synthesis Quote](#)

BenchChem

Our mission is to be the trusted global source of essential and advanced chemicals, empowering scientists and researchers to drive progress in science and industry.

Contact

Address: 3281 E Guasti Rd
Ontario, CA 91761, United States
Phone: (601) 213-4426
Email: info@benchchem.com

[Contact our Ph.D. Support Team for a compatibility check](#)