

# Technical Support Center: Mitigating Off-Target Neurological Effects of Mectizan (Ivermectin)

**Author:** BenchChem Technical Support Team. **Date:** April 2026

## Compound of Interest

Compound Name: Mectizan  
Cat. No.: B10770060

[Get Quote](#)

This technical support center provides researchers, scientists, and drug development professionals with troubleshooting guides and frequently asked questions (FAQs) to mitigate the off-target neurological effects of **Mectizan** (ivermectin) during experimental procedures.

## Troubleshooting Guides

This section offers detailed, question-and-answer-based guides to address specific experimental challenges.

Question 1: How can I proactively minimize the risk of neurotoxicity when starting experiments with **Mectizan** in a new animal model?

Answer:

A multi-faceted approach is recommended to proactively mitigate neurotoxicity risks. This involves careful model selection, dose-range finding studies, and the potential use of P-glycoprotein (P-gp) inducers.

Experimental Protocol: Initial In Vivo Neurotoxicity Risk Assessment

- Animal Model Selection:
  - Whenever possible, use animal strains with well-characterized P-gp function. Avoid strains with known deficiencies in the MDR1 gene (which encodes P-gp), such as certain collie breeds in canine studies.[1] For murine studies, C57BL/6 and BALB/c are commonly used wild-type strains.
- Dose-Range Finding Study:
  - Begin with a low-dose cohort and incrementally increase the dose in subsequent cohorts.
  - Administer **Mectizan** (e.g., subcutaneously or orally) and monitor animals closely for the first 12 hours and then at regular intervals for up to 48 hours.
  - Clinical Signs of Neurotoxicity to Monitor: Ataxia, tremors, lethargy, disorientation, mydriasis (dilated pupils), and in severe cases, seizures and coma.[1]
- Optional: P-glycoprotein Induction:
  - To enhance the blood-brain barrier's protective efflux mechanism, consider pre-treating animals with a P-gp inducer like rifampicin.
  - Rifampicin Induction Protocol (Mice): Administer rifampicin at 50 mg/kg daily for 3-4 days via oral gavage prior to **Mectizan** administration. This has been shown to increase P-gp expression at the blood-brain barrier.

Question 2: An animal in my study is exhibiting unexpected signs of neurotoxicity (e.g., ataxia, tremors). How can I confirm if this is due to increased brain penetration of **Mectizan**?

Answer:

To confirm a suspected case of **Mectizan**-induced neurotoxicity, it is crucial to quantify the concentration of the drug in both plasma and brain tissue. An elevated brain-to-plasma concentration ratio compared to control animals would suggest a compromised blood-brain barrier.

Experimental Protocol: Quantification of Ivermectin in Brain and Plasma

- Sample Collection:
  - At the time of euthanasia, collect whole blood (for plasma) and the brain.
  - Perfuse the brain with ice-cold saline to remove any remaining blood.
- Sample Preparation:
  - Homogenize the brain tissue.
  - Perform a liquid-liquid or solid-phase extraction of both the plasma and brain homogenate to isolate ivermectin.
- Quantification by HPLC-MS/MS:
  - Use a validated High-Performance Liquid Chromatography-Tandem Mass Spectrometry (HPLC-MS/MS) method for sensitive and specific quantification of ivermectin.
  - A C18 column is typically used for separation, with a mobile phase consisting of acetonitrile and water with a modifier like formic acid.
  - The mass spectrometer should be operated in multiple reaction monitoring (MRM) mode for optimal selectivity.

#### Data Presentation: Comparative Ivermectin Accumulation

Animal Model	Brain Concentration (ng/g)	Plasma Concentration (ng/mL)	Brain-to-Plasma Ratio	Reference
Wild-Type Mice	~5	~25	~0.2	[2]
P-gp Knockout Mice	~180	~30	~6.0	[2]

Question 3: I am planning to co-administer another compound with **Mectizan**. How can I assess if this new compound will increase the risk of neurotoxicity?

Answer:

The new compound could potentially inhibit P-glycoprotein, leading to increased brain accumulation of **Mectizan**. This can be assessed using an in vitro blood-brain barrier model.

Experimental Protocol: In Vitro Blood-Brain Barrier Permeability Assay

- Model Setup:
  - Use a commercially available in vitro BBB kit or establish a co-culture model. A common model involves seeding brain capillary endothelial cells on a semipermeable Transwell insert, with astrocytes cultured on the underside of the insert.
- Permeability Assay:
  - Add **Mectizan** to the apical (blood side) of the Transwell.
  - In a separate set of wells, add **Mectizan** along with the test compound.
  - Include a positive control for P-gp inhibition (e.g., verapamil).
  - At various time points, collect samples from the basolateral (brain side) chamber and quantify the concentration of **Mectizan** using HPLC-MS/MS.
- Data Analysis:
  - Calculate the apparent permeability coefficient (P<sub>app</sub>) for **Mectizan** in the presence and absence of the test compound. A significant increase in the P<sub>app</sub> value in the presence of the test compound suggests P-gp inhibition and a higher risk of in vivo neurotoxicity.

## Frequently Asked Questions (FAQs)

Q1: What is the primary mechanism of **Mectizan**'s off-target neurological effects?

**Mectizan**'s primary off-target neurological effects are due to its potentiation of GABA-gated chloride channels in the central nervous system (CNS).[3] While **Mectizan** has a high affinity for invertebrate glutamate-gated chloride channels, at higher concentrations, it can also bind to

mammalian GABAA receptors. This enhances the inhibitory effects of GABA, leading to CNS depression, ataxia, and other neurological signs.[3]

Q2: What is the role of the blood-brain barrier in preventing **Mectizan** neurotoxicity?

The blood-brain barrier (BBB) plays a crucial protective role by actively extruding **Mectizan** from the brain. This is primarily mediated by the P-glycoprotein (P-gp) efflux transporter, an ATP-dependent pump expressed on the luminal side of brain capillary endothelial cells.[1] P-gp recognizes **Mectizan** as a substrate and transports it back into the bloodstream, thus maintaining low concentrations within the CNS.[1]

Q3: Are there known genetic factors that increase susceptibility to **Mectizan** neurotoxicity?

Yes, genetic polymorphisms in the MDR1 gene (also known as ABCB1), which encodes P-gp, can lead to increased susceptibility to **Mectizan** neurotoxicity. The most well-known example is a 4-base pair deletion mutation in the MDR1 gene in some dog breeds, particularly Collies, which results in a non-functional P-gp.[1] This leads to a significantly higher accumulation of **Mectizan** in the brain and a much lower tolerance to the drug. While rare, functional polymorphisms in the human MDR1 gene also exist and may contribute to individual differences in susceptibility.

Q4: Can co-administration of other drugs increase the risk of **Mectizan**'s neurological side effects?

Yes, co-administration of drugs that are inhibitors of P-glycoprotein can increase the risk of **Mectizan** neurotoxicity. These drugs compete with **Mectizan** for binding to P-gp, thereby reducing its efflux from the brain and leading to higher CNS concentrations. Known P-gp inhibitors include certain calcium channel blockers (e.g., verapamil), immunosuppressants (e.g., cyclosporine), and some antifungals (e.g., ketoconazole).

Data Presentation: IC50 Values of P-gp Inhibitors

Compound	IC50 for P-gp Inhibition	Reference
Verapamil	~1-5 $\mu$ M	
Cyclosporine A	~0.5-2 $\mu$ M	[1]
Ketoconazole	~1-10 $\mu$ M	
Ivermectin	~0.1-2.5 $\mu$ M	

Q5: What in vitro models are suitable for studying **Mectizan**-induced neurotoxicity?

Neuronal cell lines, such as the human neuroblastoma cell line SH-SY5Y, are valuable in vitro models for investigating the molecular mechanisms of **Mectizan**-induced neurotoxicity.[4][5][6][7][8] These cells can be used to perform cell viability assays (e.g., MTT, CellTiter-Glo) to determine the cytotoxic concentrations of **Mectizan** and to study downstream signaling pathways.

Experimental Protocol: Cell Viability Assay (MTT)

- Cell Seeding: Plate SH-SY5Y cells in a 96-well plate and allow them to adhere overnight.
- Treatment: Treat the cells with a range of **Mectizan** concentrations for a specified duration (e.g., 24, 48, or 72 hours).
- MTT Addition: Add MTT solution to each well and incubate for 2-4 hours to allow for the formation of formazan crystals.
- Solubilization: Add a solubilization solution (e.g., DMSO) to dissolve the formazan crystals.
- Absorbance Measurement: Read the absorbance at a wavelength of 570 nm using a microplate reader. The absorbance is proportional to the number of viable cells.

Q6: What are some strategies to reduce **Mectizan**'s brain penetration in experimental settings?

Beyond avoiding P-gp inhibitors and using P-gp inducers, novel drug delivery strategies are being explored. For instance, nanoencapsulation of **Mectizan** in polymeric nanocapsules has

been shown to alter its biodistribution and could potentially be optimized to reduce BBB penetration for non-CNS targets.

## Visualizations

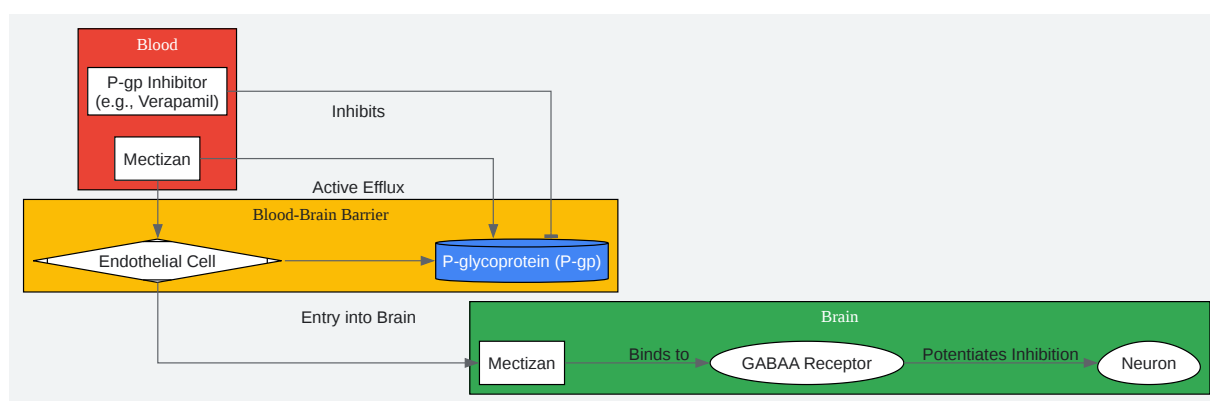

[Click to download full resolution via product page](#)

Caption: **Mectizan** transport across the blood-brain barrier.

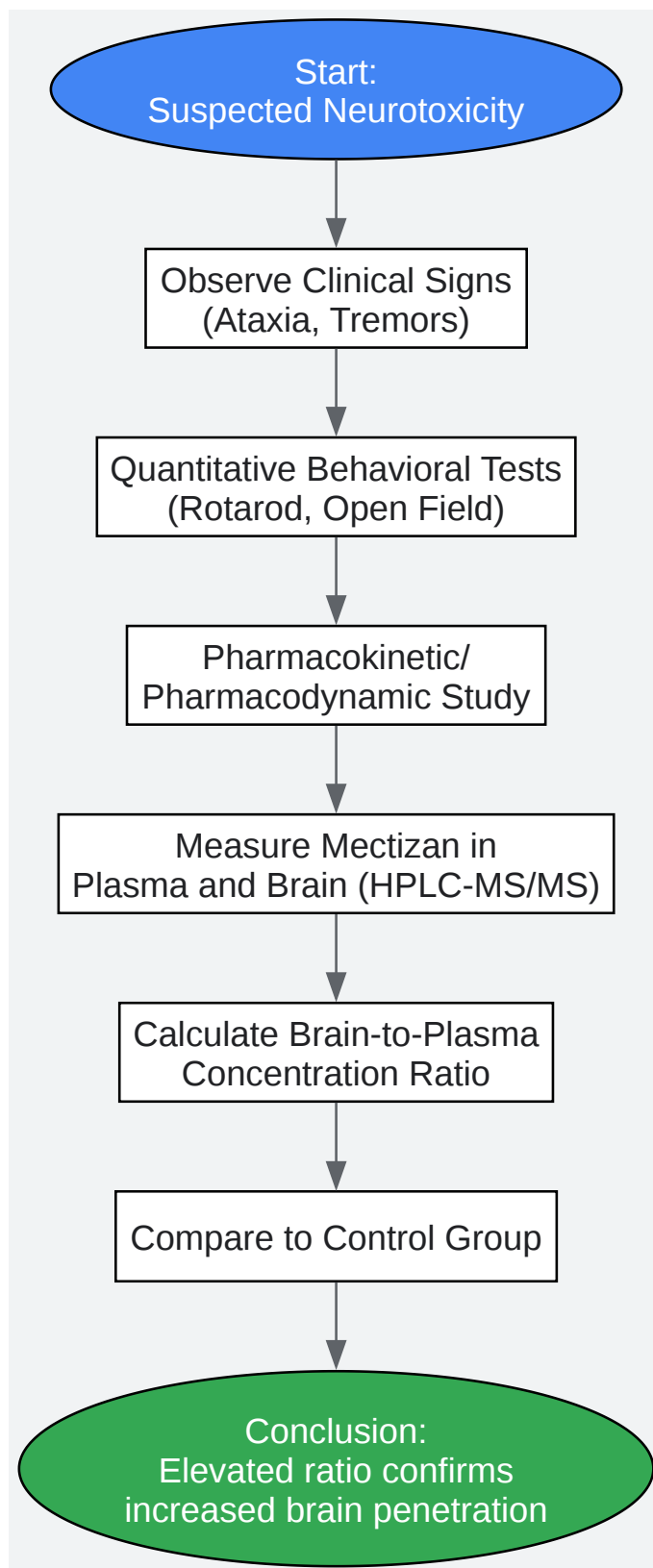

[Click to download full resolution via product page](#)

Caption: Experimental workflow for investigating suspected neurotoxicity.

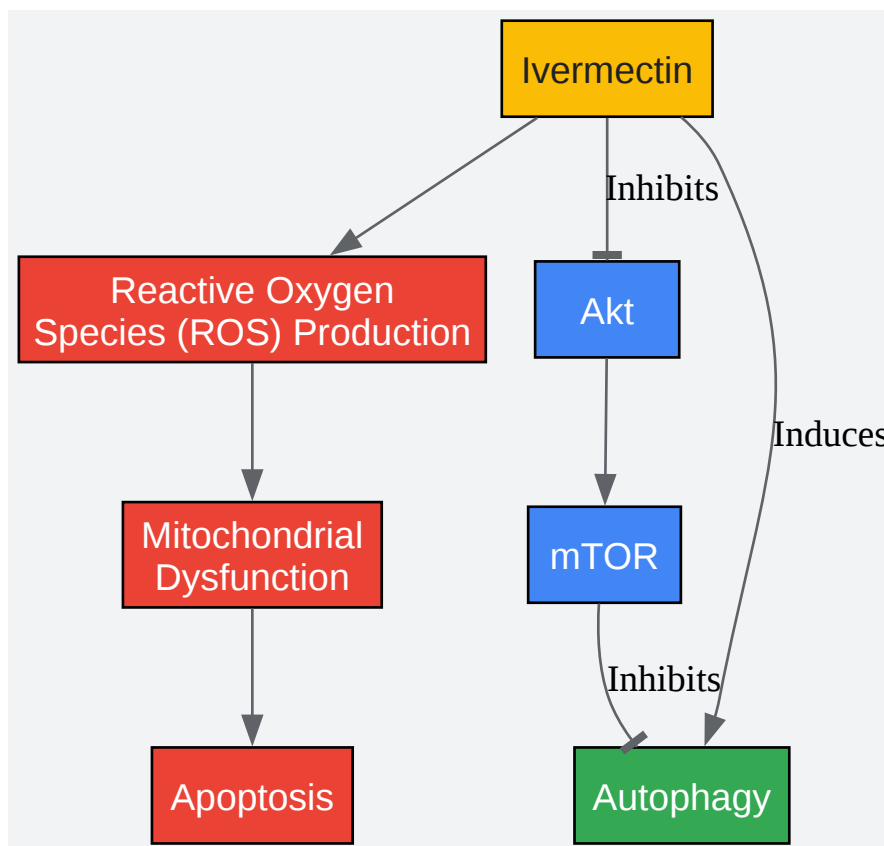

[Click to download full resolution via product page](#)

Caption: Ivermectin-induced signaling pathways in neuronal cells.

### Need Custom Synthesis?

BenchChem offers custom synthesis for rare earth carbides and specific isotopic labeling.

Email: [info@benchchem.com](mailto:info@benchchem.com) or [Request Quote Online](#).

## References

- 1. Ivermectin: does P-glycoprotein play a role in neurotoxicity? - PMC [pmc.ncbi.nlm.nih.gov]
- 2. Brain penetration of ivermectin and selamectin in mdr1a,b P-glycoprotein- and bcrp-deficient knockout mice - PubMed [pubmed.ncbi.nlm.nih.gov]
- 3. Effect of ivermectin on gamma-aminobutyric acid-induced chloride currents in mouse hippocampal embryonic neurones - PubMed [pubmed.ncbi.nlm.nih.gov]

- [4. Ivermectin-Induced Apoptotic Cell Death in Human SH-SY5Y Cells Involves the Activation of Oxidative Stress and Mitochondrial Pathway and Akt/mTOR-Pathway-Mediated Autophagy - PMC \[pmc.ncbi.nlm.nih.gov\]](#)
- [5. \[PDF\] Ivermectin-Induced Apoptotic Cell Death in Human SH-SY5Y Cells Involves the Activation of Oxidative Stress and Mitochondrial Pathway and Akt/mTOR-Pathway-Mediated Autophagy | Semantic Scholar \[semanticscholar.org\]](#)
- [6. Ivermectin-Induced Apoptotic Cell Death in Human SH-SY5Y Cells Involves the Activation of Oxidative Stress and Mitochondrial Pathway and Akt/mTOR-Pathway-Mediated Autophagy - PubMed \[pubmed.ncbi.nlm.nih.gov\]](#)
- [7. researchgate.net \[researchgate.net\]](#)
- [8. researchgate.net \[researchgate.net\]](#)
- To cite this document: BenchChem. [Technical Support Center: Mitigating Off-Target Neurological Effects of Mectizan (Ivermectin)]. BenchChem, [2026]. [Online PDF]. Available at: [<https://www.benchchem.com/product/b10770060/docs#technical-support-center-mitigating-off-target-neurological-effects-of-mectizan-ivermectin>]

---

#### Disclaimer & Data Validity:

The information provided in this document is for Research Use Only (RUO) and is strictly not intended for diagnostic or therapeutic procedures. While BenchChem strives to provide accurate protocols, we make no warranties, express or implied, regarding the fitness of this product for every specific experimental setup.

**Technical Support:** The protocols provided are for reference purposes. Unsure if this reagent suits your experiment?

**Need Industrial/Bulk Grade?** [Request Custom Synthesis Quote](#)

## BenchChem

Our mission is to be the trusted global source of essential and advanced chemicals, empowering scientists and researchers to drive progress in science and industry.

#### Contact

Address: 3281 E Guasti Rd  
Ontario, CA 91761, United States  
Phone: (601) 213-4426  
Email: [info@benchchem.com](mailto:info@benchchem.com)

Contact our Ph.D. Support Team for a compatibility check