

Validating the On-Target Activity of ML-00253764 Hydrochloride: A Comparative Guide

Author: BenchChem Technical Support Team. **Date:** April 2026

Compound of Interest

Compound Name: ML-00253764 hydrochloride

Cat. No.: B10769235

Get Quote

This guide provides a comprehensive comparison of **ML-00253764 hydrochloride**'s on-target activity with alternative compounds, supported by experimental data and detailed protocols. It is designed for researchers, scientists, and drug development professionals working with melanocortin receptor modulators.

On-Target Activity Profile: ML-00253764 Hydrochloride and Alternatives

ML-00253764 hydrochloride is a brain-penetrant, nonpeptidic antagonist of the melanocortin 4 receptor (MC4R).^{[1][2]} Its on-target activity is characterized by its binding affinity (K_i) and its functional inhibition of the receptor (IC_{50}). A comparative summary of **ML-00253764 hydrochloride** against other known MC4R antagonists, SHU-9119 and HS024, is presented below.

Compound	Target	Ki (nM)	IC50 (nM)	Selectivity Profile
ML-00253764 hydrochloride	hMC4R	160	103 - 320	Selective for MC4R over MC3R and MC5R.[1][2][3]
hMC3R	-	810		
hMC5R	-	2120		
SHU-9119	hMC4R	-	0.06	Potent antagonist at MC3R and MC4R; partial agonist at MC5R.[4]
hMC3R	-	0.23		
hMC5R	-	0.09 (agonist)		
HS024	hMC4R	0.29	-	Highly potent and selective for MC4R (approximately 20-fold).[5]

Signaling Pathways and Experimental Workflows

The primary mechanism of action for **ML-00253764 hydrochloride** is the antagonism of the MC4R, which is a G-protein coupled receptor (GPCR) that primarily signals through the Gαs-adenylyl cyclase pathway to produce cyclic AMP (cAMP).[2] Inhibition of MC4R by ML-00253764 has also been shown to suppress the phosphorylation of downstream signaling molecules ERK1/2 and Akt in certain cancer cell lines.[6][7]

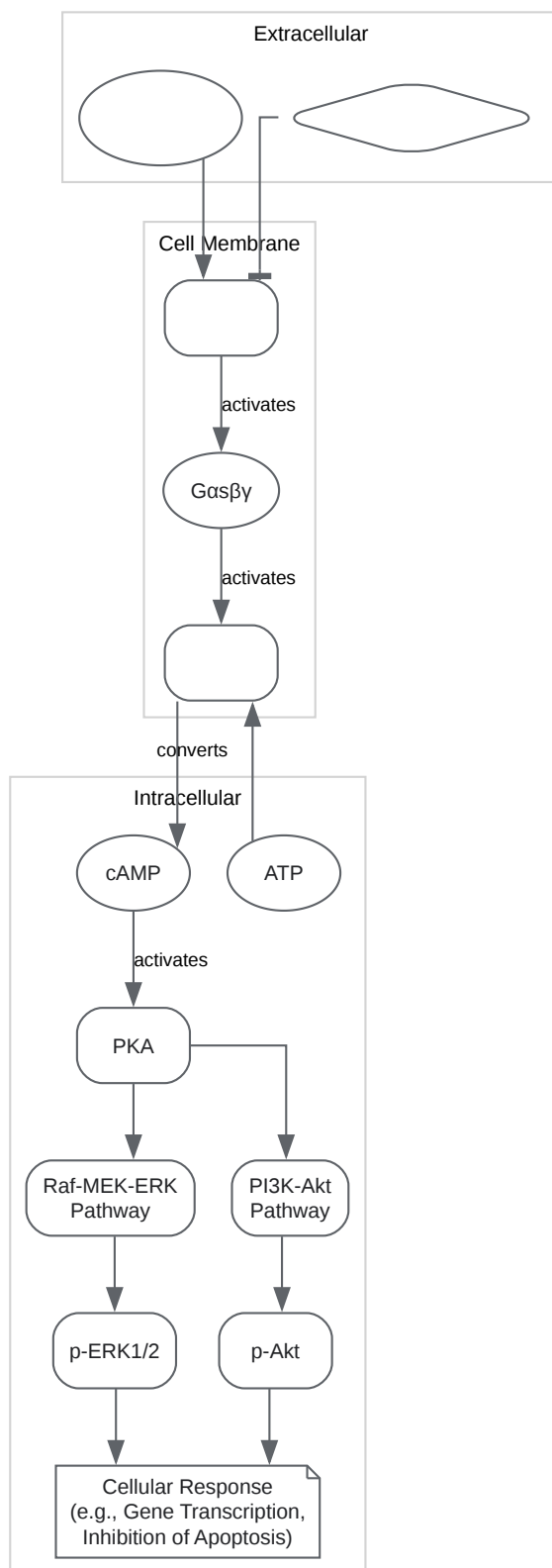

[Click to download full resolution via product page](#)

MC4R Signaling Pathway.

Experimental Validation Workflows

The on-target activity of MC4R antagonists is typically validated through two key assays: a receptor binding assay to determine affinity and a functional assay to measure antagonist potency.

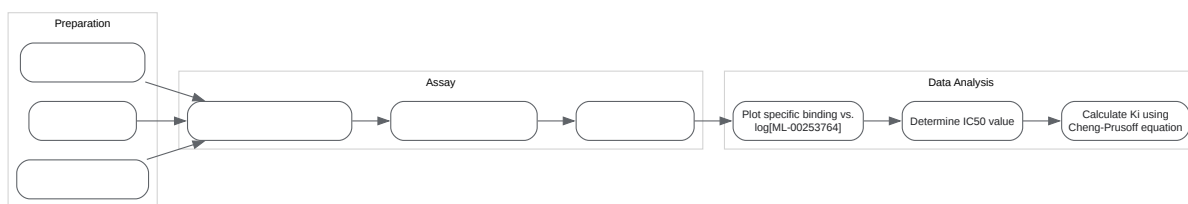

[Click to download full resolution via product page](#)

Competitive Radioligand Binding Assay Workflow.

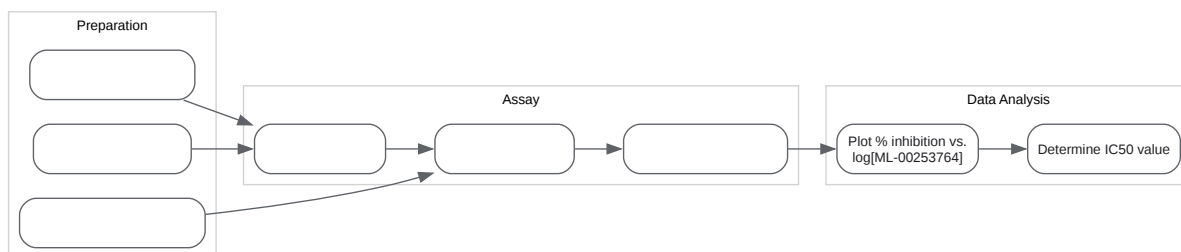

[Click to download full resolution via product page](#)

cAMP Functional Antagonist Assay Workflow.

Experimental Protocols

Radioligand Binding Assay

This protocol is for determining the binding affinity (K_i) of **ML-00253764 hydrochloride** for the human MC4R.

Materials:

- HEK293 cells stably expressing human MC4R
- Radioligand: [125 I]-(Nle⁴, D-Phe⁷)- α -MSH ([125 I]-NDP-MSH)
- Unlabeled ligand: **ML-00253764 hydrochloride**
- Binding Buffer: 50 mM Tris-HCl, pH 7.4, with 5 mM MgCl₂, 1 mM CaCl₂, and 0.2% BSA
- Wash Buffer: Ice-cold 50 mM Tris-HCl, pH 7.4
- Glass fiber filters (e.g., GF/C)
- Scintillation counter

Procedure:

- Membrane Preparation: Homogenize MC4R-expressing HEK293 cells in ice-cold buffer and centrifuge to pellet the membranes. Resuspend the membrane pellet in binding buffer. Determine protein concentration using a standard assay (e.g., BCA).
- Assay Setup: In a 96-well plate, add the following in order:
 - Binding buffer
 - A fixed concentration of [125 I]-NDP-MSH (typically at its K_d)
 - Increasing concentrations of **ML-00253764 hydrochloride** (for displacement curve) or buffer (for total binding) or a high concentration of unlabeled agonist (for non-specific binding).

- A constant amount of the cell membrane preparation.
- Incubation: Incubate the plate for 60-120 minutes at room temperature with gentle agitation to reach equilibrium.
- Filtration: Rapidly filter the contents of each well through a pre-soaked glass fiber filter using a cell harvester. Wash the filters multiple times with ice-cold wash buffer to remove unbound radioligand.
- Counting: Measure the radioactivity retained on the dried filters using a gamma counter.
- Data Analysis:
 - Calculate specific binding: Total binding - Non-specific binding.
 - Plot the percentage of specific binding against the logarithm of the **ML-00253764 hydrochloride** concentration.
 - Fit the data to a sigmoidal dose-response curve to determine the IC50 value.
 - Calculate the Ki value using the Cheng-Prusoff equation: $K_i = IC_{50} / (1 + ([L]/K_d))$, where [L] is the concentration of the radioligand and Kd is its dissociation constant.

cAMP Functional Antagonist Assay

This protocol measures the ability of **ML-00253764 hydrochloride** to inhibit agonist-induced cAMP production in cells expressing MC4R.

Materials:

- HEK293 or CHO cells stably expressing human MC4R
- **ML-00253764 hydrochloride**
- MC4R agonist (e.g., α -MSH or NDP- α -MSH)
- Stimulation Buffer: Serum-free medium containing a phosphodiesterase inhibitor (e.g., 0.5 mM IBMX) to prevent cAMP degradation.

- cAMP assay kit (e.g., HTRF, ELISA, or AlphaScreen)

Procedure:

- Cell Preparation: Plate MC4R-expressing cells in a 96-well plate and allow them to adhere overnight.
- Antagonist Pre-incubation: Replace the culture medium with stimulation buffer. Add increasing concentrations of **ML-00253764 hydrochloride** to the wells and pre-incubate for a defined period (e.g., 15-30 minutes).
- Agonist Stimulation: Add a fixed concentration of the MC4R agonist (typically the EC80 concentration) to the wells and incubate for a specified time (e.g., 30-60 minutes) at 37°C.
- Cell Lysis and cAMP Measurement: Stop the reaction and lyse the cells according to the cAMP assay kit manufacturer's instructions. Measure the intracellular cAMP levels.
- Data Analysis:
 - Generate a standard curve using known concentrations of cAMP.
 - Convert the raw assay signal for each sample into a cAMP concentration.
 - Plot the percentage of inhibition of the agonist response against the logarithm of the **ML-00253764 hydrochloride** concentration.
 - Fit the data to a sigmoidal dose-response curve to determine the IC50 value.

Need Custom Synthesis?

BenchChem offers custom synthesis for rare earth carbides and specific isotopic labeling.

Email: info@benchchem.com or [Request Quote Online](#).

References

- [1. Melanocortin 4 Receptor Pathway Dysfunction in Obesity: Patient Stratification Aimed at MC4R Agonist Treatment - PMC \[pmc.ncbi.nlm.nih.gov\]](#)

- [2. benchchem.com \[benchchem.com\]](https://www.benchchem.com)
- [3. Monogenic obesity - Wikipedia \[en.wikipedia.org\]](https://en.wikipedia.org)
- [4. medchemexpress.com \[medchemexpress.com\]](https://www.medchemexpress.com)
- [5. Discovery of a novel superpotent and selective melanocortin-4 receptor antagonist \(HS024\): evaluation in vitro and in vivo - PubMed \[pubmed.ncbi.nlm.nih.gov\]](https://pubmed.ncbi.nlm.nih.gov)
- [6. researchgate.net \[researchgate.net\]](https://www.researchgate.net)
- [7. researchgate.net \[researchgate.net\]](https://www.researchgate.net)
- To cite this document: BenchChem. [Validating the On-Target Activity of ML-00253764 Hydrochloride: A Comparative Guide]. BenchChem, [2026]. [Online PDF]. Available at: [\[https://www.benchchem.com/product/b10769235/docs#validating-the-on-target-activity-of-ml-00253764-hydrochloride-a-comparative-guide\]](https://www.benchchem.com/product/b10769235/docs#validating-the-on-target-activity-of-ml-00253764-hydrochloride-a-comparative-guide)

Disclaimer & Data Validity:

The information provided in this document is for Research Use Only (RUO) and is strictly not intended for diagnostic or therapeutic procedures. While BenchChem strives to provide accurate protocols, we make no warranties, express or implied, regarding the fitness of this product for every specific experimental setup.

Technical Support: The protocols provided are for reference purposes. Unsure if this reagent suits your experiment?

Need Industrial/Bulk Grade? [Request Custom Synthesis Quote](#)

BenchChem

Our mission is to be the trusted global source of essential and advanced chemicals, empowering scientists and researchers to drive progress in science and industry.

Contact

Address: 3281 E Guasti Rd

Ontario, CA 91761, United States

Phone: (601) 213-4426

Email: info@benchchem.com

Contact our Ph.D. Support Team for a compatibility check