

# Technical Support Center: U0126 Treatment

**Author:** BenchChem Technical Support Team. **Date:** April 2026

## Compound of Interest

Compound Name: U0124  
Cat. No.: B10769467

[Get Quote](#)

This technical support center provides troubleshooting guides and frequently asked questions (FAQs) to address inconsistent results encountered during experiments with the MEK1/2 inhibitor, U0126.

## Frequently Asked Questions (FAQs) & Troubleshooting

**Q1:** My U0126 inhibitor doesn't seem to be working. Western blot analysis shows no decrease in phosphorylated ERK (p-ERK). What could be the issue?

**A1:** Several factors could contribute to the lack of U0126 efficacy. Consider the following troubleshooting steps:

- Inhibitor Preparation and Storage:
  - Improper Dissolving: U0126 is soluble in DMSO and methanol, but has very poor solubility in water.<sup>[1][2]</sup> Ensure the compound is fully dissolved in the appropriate solvent before further dilution in aqueous media.
  - Incorrect Stock Concentration: Double-check your calculations for the stock solution. A common stock concentration is 10 mM in DMSO.<sup>[1][3]</sup>

- Degradation: U0126 is sensitive to multiple freeze-thaw cycles.[1][4] It is recommended to aliquot the stock solution into single-use volumes and store at -20°C.[1][4] Once in solution, it should be used within 3 months to prevent loss of potency.[1] Lyophilized powder is stable for up to 24 months when stored at -20°C and desiccated.[1]
- Experimental Conditions:
  - Insufficient Concentration: The effective concentration of U0126 can vary significantly between cell lines. A typical starting concentration is 10 μM, but higher concentrations may be necessary.[1] Perform a dose-response experiment to determine the optimal concentration for your specific cell line.
  - Inadequate Treatment Time: For cultured cells, a pre-treatment time of 30 minutes to 2 hours prior to stimulation is often recommended.[1] However, the optimal duration may vary depending on the experimental context.
  - High Cell Confluency: Overly confluent cells can sometimes be less responsive to treatment. Ensure your cells are in the logarithmic growth phase and at an appropriate density (e.g., 70% confluency) during treatment.[5]
- Cell Line-Specific Factors:
  - Constitutively Active Pathway: Some cell lines may have a highly activated Ras/Raf/MEK/ERK pathway due to mutations, which might require higher concentrations or longer treatment times to achieve inhibition.[6]
  - Drug Efflux Pumps: Certain cell lines may express high levels of drug efflux pumps that actively remove U0126 from the cell, reducing its intracellular concentration and efficacy.

Q2: I'm observing unexpected or inconsistent phenotypic results (e.g., changes in apoptosis, autophagy) with U0126 treatment. Why is this happening?

A2: U0126 can have complex effects on cellular processes that may seem counterintuitive or vary between cell types.

- Dual Role in Apoptosis: U0126 has been reported to both inhibit and induce apoptosis.[7] For instance, it can protect against cisplatin-induced renal injury by decreasing apoptosis, while

in other contexts, it can induce apoptosis to inhibit tumor proliferation.[7] The outcome is highly dependent on the cellular context and the specific stimuli involved.

- Inhibition of Autophagy: U0126 has been shown to suppress autophagy in several studies.[7] [8] If your experimental outcome is influenced by autophagy, this effect of U0126 could lead to unexpected results.
- Off-Target Effects: Although U0126 is considered highly selective for MEK1 and MEK2, off-target effects have been reported.[9][10] For example, U0126 has been shown to reduce agonist-induced calcium entry into cells, independent of its MEK-inhibitory activity.[10] It has also been reported to affect Kv4.2 channel inactivation.[11] These off-target effects could contribute to inconsistent or unexpected phenotypes.

Q3: What is the recommended protocol for preparing and using U0126?

A3: Here is a general protocol for the preparation and use of U0126 in cell culture experiments.

Preparation of U0126 Stock Solution (10 mM):

- U0126 is typically supplied as a lyophilized powder.[1]
- To prepare a 10 mM stock solution, reconstitute the powder in an appropriate volume of DMSO. For example, for 5 mg of U0126 (MW: 380.49 g/mol ), add 1.31 mL of DMSO.[1]
- Vortex thoroughly to ensure the compound is completely dissolved.
- Aliquot the stock solution into smaller, single-use volumes in sterile microcentrifuge tubes.
- Store the aliquots at -20°C and protect from light.[4] Avoid repeated freeze-thaw cycles.[1][4]

Cell Treatment Protocol:

- Culture your cells to the desired confluency (typically 70-80%).
- Thaw a single aliquot of the U0126 stock solution.
- Dilute the stock solution to the desired final concentration in your cell culture medium. It is important to mix the U0126-containing medium thoroughly.

- For experiments involving stimulation, pre-treat the cells with the U0126-containing medium for 30 minutes to 2 hours before adding the stimulus.[\[1\]](#)
- Incubate the cells for the desired treatment duration.
- After treatment, proceed with your downstream analysis (e.g., cell lysis for Western blot, cell viability assay).

## Quantitative Data Summary

Table 1: IC50 Values for U0126

Target	IC50	Notes
MEK1	72 nM	Non-competitive inhibition with respect to ATP and ERK. <a href="#">[2]</a> <a href="#">[9]</a> <a href="#">[12]</a>
MEK2	58 nM	Non-competitive inhibition with respect to ATP and ERK. <a href="#">[2]</a> <a href="#">[9]</a> <a href="#">[12]</a>

## Experimental Protocols

### Key Experiment: Western Blot for p-ERK and Total ERK

This protocol outlines the steps to assess the efficacy of U0126 by measuring the levels of phosphorylated ERK (p-ERK) and total ERK.

#### 1. Cell Lysis:

- After U0126 treatment, wash the cells twice with ice-cold PBS.
- Add an appropriate volume of ice-cold lysis buffer (e.g., RIPA buffer) supplemented with protease and phosphatase inhibitors.
- Scrape the cells and transfer the lysate to a pre-chilled microcentrifuge tube.
- Incubate on ice for 30 minutes, vortexing occasionally.

- Centrifuge at 14,000 x g for 15 minutes at 4°C to pellet the cell debris.
  - Transfer the supernatant (protein lysate) to a new tube.
2. Protein Quantification:
- Determine the protein concentration of each lysate using a standard protein assay (e.g., BCA assay).
3. Sample Preparation and SDS-PAGE:
- Normalize the protein concentration for all samples.
  - Add Laemmli sample buffer to the lysates and boil at 95-100°C for 5 minutes.
  - Load equal amounts of protein per lane onto an SDS-polyacrylamide gel.
  - Run the gel until the dye front reaches the bottom.
4. Protein Transfer:
- Transfer the separated proteins from the gel to a PVDF or nitrocellulose membrane.
5. Immunoblotting:
- Block the membrane with a suitable blocking buffer (e.g., 5% non-fat dry milk or BSA in TBST) for 1 hour at room temperature or overnight at 4°C.[\[13\]](#)
  - Incubate the membrane with a primary antibody specific for p-ERK overnight at 4°C with gentle agitation.
  - Wash the membrane three times with TBST for 5-10 minutes each.
  - Incubate the membrane with a horseradish peroxidase (HRP)-conjugated secondary antibody for 1 hour at room temperature.
  - Wash the membrane three times with TBST for 5-10 minutes each.

- Detect the signal using an enhanced chemiluminescence (ECL) substrate and an imaging system.
6. Stripping and Re-probing (for Total ERK):
- After imaging for p-ERK, the membrane can be stripped of the antibodies.
  - Re-block the membrane and probe with a primary antibody for total ERK, followed by the secondary antibody and detection steps as described above. Total ERK serves as a loading control.

## Visualizations

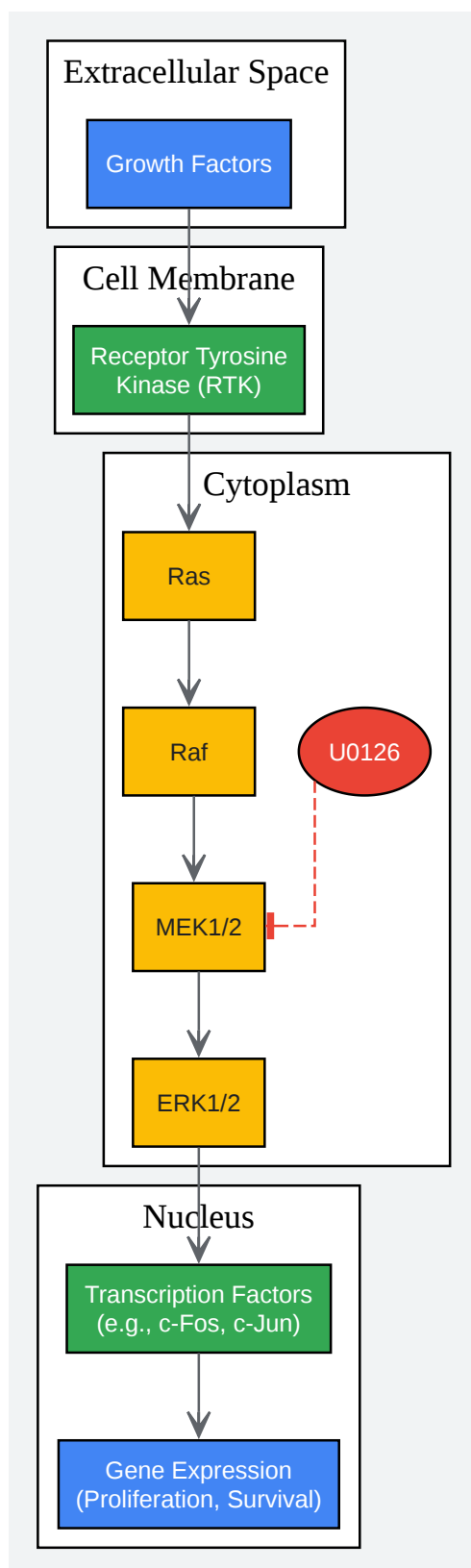

[Click to download full resolution via product page](#)

Caption: The MEK-ERK signaling pathway and the inhibitory action of U0126.

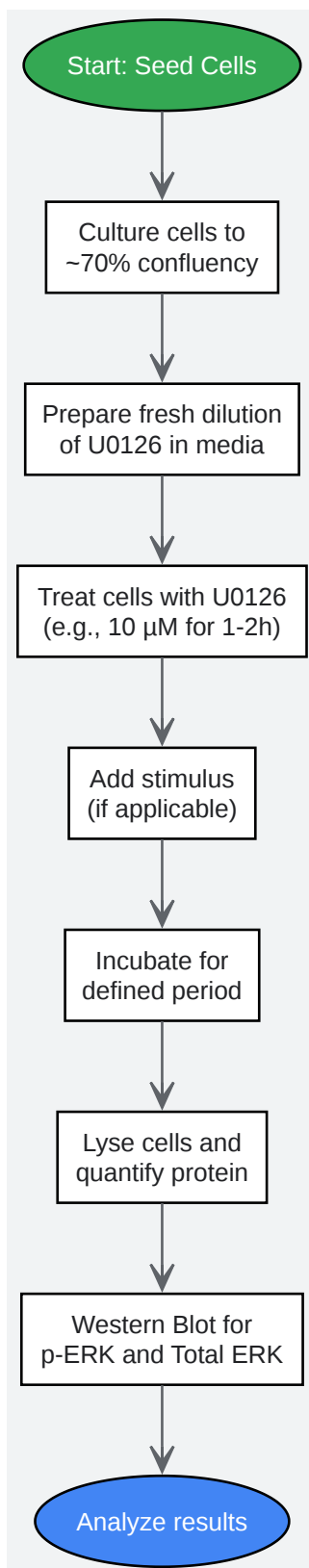

[Click to download full resolution via product page](#)

Caption: A typical experimental workflow for U0126 treatment and analysis.

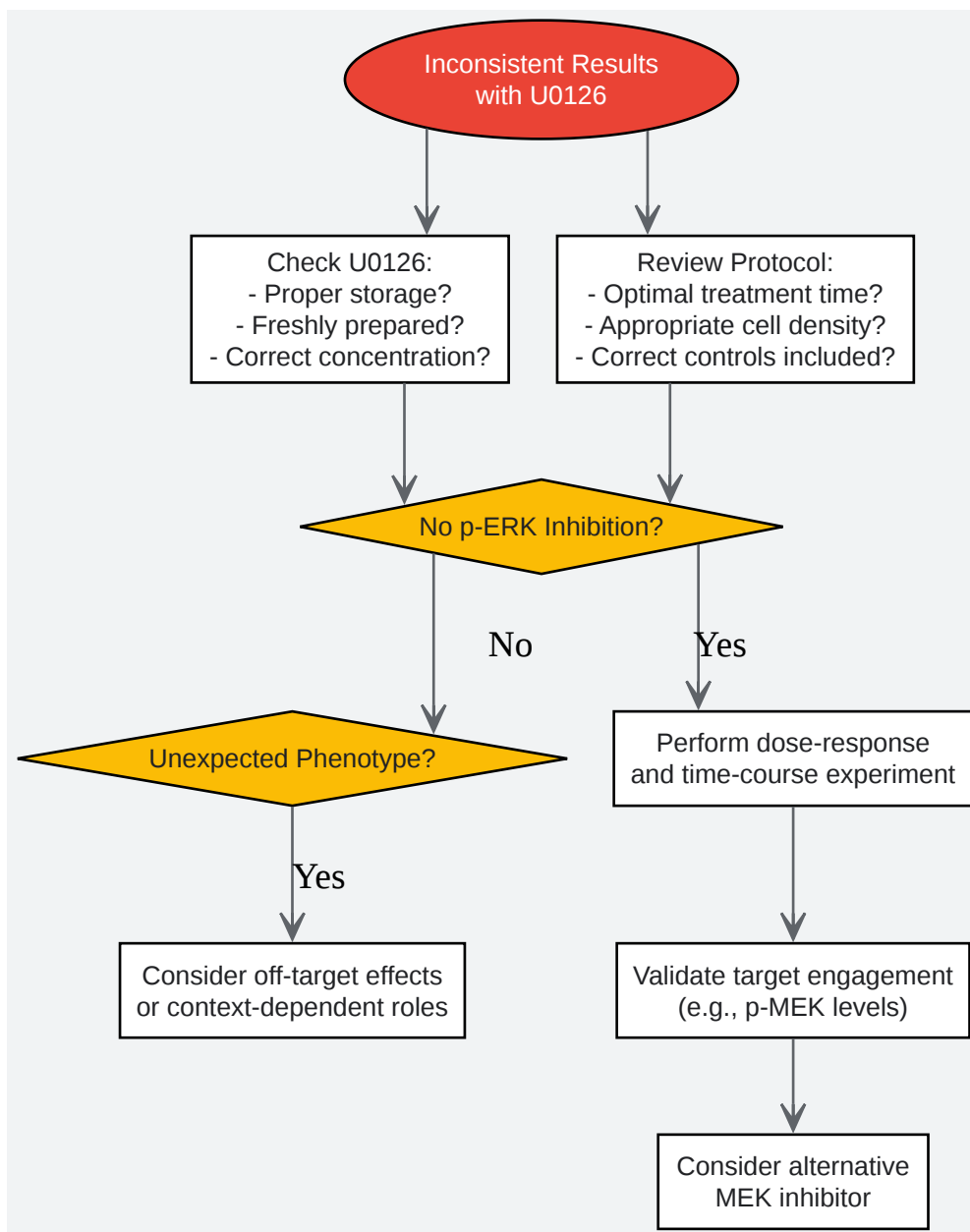

[Click to download full resolution via product page](#)

Caption: A logical troubleshooting guide for inconsistent U0126 results.

### Need Custom Synthesis?

BenchChem offers custom synthesis for rare earth carbides and specific isotopic labeling.

Email: [info@benchchem.com](mailto:info@benchchem.com) or [Request Quote Online](#).

## References

- [1. U0126 | Cell Signaling Technology \[cellsignal.com\]](#)
- [2. reagentsdirect.com \[reagentsdirect.com\]](#)
- [3. MEK Inhibitor U0126 \[promega.com\]](#)
- [4. InSolution U0126 \[sigmaaldrich.com\]](#)
- [5. licorbio.com \[licorbio.com\]](#)
- [6. aacrjournals.org \[aacrjournals.org\]](#)
- [7. U0126: Not only a MAPK kinase inhibitor - PMC \[pmc.ncbi.nlm.nih.gov\]](#)
- [8. invivogen.com \[invivogen.com\]](#)
- [9. U0126 - Wikipedia \[en.wikipedia.org\]](#)
- [10. Off-target effects of MEK inhibitors - PMC \[pmc.ncbi.nlm.nih.gov\]](#)
- [11. journals.physiology.org \[journals.physiology.org\]](#)
- [12. medchemexpress.com \[medchemexpress.com\]](#)
- [13. Western blot protocol | Abcam \[abcam.com\]](#)
- [To cite this document: BenchChem. \[Technical Support Center: U0126 Treatment\]. BenchChem, \[2026\]. \[Online PDF\]. Available at: \[https://www.benchchem.com/product/b10769467/docs#technical-support-center-u0126-treatment\]](#)

---

### Disclaimer & Data Validity:

The information provided in this document is for Research Use Only (RUO) and is strictly not intended for diagnostic or therapeutic procedures. While BenchChem strives to provide accurate protocols, we make no warranties, express or implied, regarding the fitness of this product for every specific experimental setup.

**Technical Support:** The protocols provided are for reference purposes. Unsure if this reagent suits your experiment?

**Need Industrial/Bulk Grade?** [Request Custom Synthesis Quote](#)

# BenchChem

Our mission is to be the trusted global source of essential and advanced chemicals, empowering scientists and researchers to drive progress in science and industry.

## Contact

Address: 3281 E Guasti Rd

Ontario, CA 91761, United States

Phone: (601) 213-4426

Email: [info@benchchem.com](mailto:info@benchchem.com)

[Contact our Ph.D. Support Team for a compatibility check](#)