

The Role of ROMK Channels in Renal Physiology: A Technical Guide

Author: BenchChem Technical Support Team. **Date:** April 2026

Compound of Interest

Compound Name: VU591 hydrochloride

Cat. No.: B10768957

[Get Quote](#)

For Researchers, Scientists, and Drug Development Professionals

Executive Summary

The Renal Outer Medullary Potassium (ROMK) channel, a member of the inwardly-rectifying potassium (Kir) channel family (Kir1.1), is a cornerstone of renal physiology, playing a critical role in salt and potassium homeostasis.[1] Encoded by the KCNJ1 gene, this ATP-dependent potassium channel is predominantly expressed in the apical membrane of epithelial cells in the thick ascending limb (TAL) of Henle's loop and the cortical collecting duct (CCD).[2][3] In the TAL, ROMK facilitates potassium recycling, a process essential for the function of the Na-K-2Cl cotransporter (NKCC2) and, consequently, for salt reabsorption and the generation of the corticomedullary osmotic gradient.[1][4] In the CCD, ROMK is the primary channel for potassium secretion, a key determinant of final urinary potassium excretion.[1][4] Dysfunctional ROMK channels are implicated in Bartter syndrome type II, a severe salt-wasting disorder, highlighting their physiological significance.[5][6] The intricate regulation of ROMK by various signaling pathways, including phosphorylation and protein-protein interactions, fine-tunes its activity to match physiological demands. This central role in renal electrolyte handling makes ROMK an attractive target for novel diuretic therapies.[7][8] This guide provides an in-depth

examination of ROMK's function, regulation, and the experimental methodologies used to study it, tailored for professionals in biomedical research and drug development.

Core Functions and Physiological Significance

ROMK channels are integral to two primary processes in the kidney: potassium recycling in the TAL and potassium secretion in the CCD.[4]

- **Thick Ascending Limb (TAL):** In the TAL, ROMK channels on the apical membrane allow potassium that has been brought into the cell by the NKCC2 cotransporter to recycle back into the tubular lumen.[1] This recycling is crucial for several reasons: it maintains a luminal potassium concentration sufficient to support continued NKCC2 activity, contributes to the generation of a lumen-positive transepithelial voltage which drives the paracellular reabsorption of cations like sodium, calcium, and magnesium, and hyperpolarizes the apical membrane, providing a favorable electrochemical gradient for chloride exit across the basolateral membrane.[4]
- **Cortical Collecting Duct (CCD):** In the principal cells of the CCD, ROMK channels are the main conduit for potassium secretion into the tubular fluid.[1] This process is tightly coupled to sodium reabsorption via the epithelial sodium channel (ENaC). The activity of ROMK channels in the CCD is the final and most critical regulatory step in determining the amount of potassium excreted in the urine, thereby playing a pivotal role in maintaining overall potassium balance.[3][4]

The importance of ROMK is underscored by the clinical manifestations of its dysfunction. Loss-of-function mutations in the KCNJ1 gene lead to Antenatal Bartter Syndrome Type II, a life-threatening genetic disorder characterized by severe salt wasting, polyuria, hypokalemia, and metabolic alkalosis.[5][9] This phenotype is recapitulated in ROMK knockout mouse models. [10][11]

Biophysical and Pharmacological Properties

ROMK channels exhibit distinct biophysical characteristics that are well-suited for their physiological roles. They are characterized by weak inward rectification, which allows for significant outward potassium flux at physiological membrane potentials, a key feature for

potassium secretion.[1] The channel's activity is also sensitive to intracellular pH, with acidification leading to channel closure.[12]

Property	Typical Value(s)	Significance in Renal Function
Single-Channel Conductance	30-40 pS (in the CCD)	Allows for efficient potassium secretion.[1]
70-80 pS (in the TAL, likely a heteromer)	Facilitates high-capacity potassium recycling.[10][13]	
Open Probability (Po)	High at physiological membrane potentials	Ensures a continuous pathway for potassium movement.[1]
Ion Selectivity	Highly selective for K ⁺ over Na ⁺	Maintains the specific function of potassium transport.[14]
Inward Rectification	Weak	Permits robust outward potassium flux for secretion.[1]
pH Sensitivity (Intracellular)	Inhibited by acidosis (pH < 7.0)	Links channel activity to the metabolic state of the cell.
ATP Sensitivity	Inhibited by cytoplasmic ATP (in the presence of CFTR)	Couples channel activity to cellular energy status.[1][4]

Regulation of ROMK Channel Activity

The activity of ROMK channels is exquisitely regulated at multiple levels, including channel gating, trafficking to and from the plasma membrane, and protein-protein interactions. This complex regulatory network allows the kidney to precisely control potassium excretion in response to physiological cues such as dietary potassium intake and hormonal signals.

Regulation by Phosphorylation

Phosphorylation is a key mechanism controlling ROMK activity. Several kinases have been shown to directly or indirectly modulate the channel.

- **Protein Kinase A (PKA):** PKA-mediated phosphorylation is a primary mechanism for activating ROMK channels.[4] There are three key PKA phosphorylation sites on ROMK: S44 in the N-terminus and S219 and S313 in the C-terminus.[1] Phosphorylation of S44 is crucial for the channel's exit from the endoplasmic reticulum and its trafficking to the plasma membrane.[1] Phosphorylation of the C-terminal sites maintains the channel in a high open probability state.[1] The effect of PKA on ROMK is often facilitated by A-kinase anchoring proteins (AKAPs), which bring PKA into close proximity with the channel.[4]
- **Protein Kinase C (PKC):** The role of PKC in ROMK regulation is more complex. While direct phosphorylation of certain serine residues by PKC appears to be important for the surface expression of the channel, overall PKC activation is generally considered to be inhibitory.[13] This inhibition may be mediated, in part, through the hydrolysis of phosphatidylinositol 4,5-bisphosphate (PIP2), a phospholipid essential for ROMK activity.[1]
- **Protein Tyrosine Kinases (PTKs):** PTKs, such as Src kinase, play a significant role in the downregulation of ROMK channels, particularly in response to low dietary potassium.[15] Increased PTK activity leads to the tyrosine phosphorylation of ROMK, which promotes the channel's internalization from the plasma membrane via endocytosis, thereby reducing potassium secretion.[15]
- **With-No-Lysine (WNK) Kinases:** WNK kinases are critical regulators of ROMK trafficking. WNK4, for instance, promotes the clathrin-dependent endocytosis of ROMK, leading to a decrease in channel density at the apical membrane.[1] This is a key mechanism for reducing potassium secretion during periods of potassium restriction.

Regulation by Membrane Trafficking

The number of active ROMK channels at the apical membrane is dynamically regulated by a balance between exocytosis (insertion into the membrane) and endocytosis (removal from the membrane).

- **Forward Trafficking:** The transport of newly synthesized ROMK channels from the endoplasmic reticulum to the Golgi and finally to the plasma membrane is a regulated process. As mentioned, PKA-mediated phosphorylation of S44 is a critical step in allowing the channel to exit the ER.[1]

- Endocytosis: ROMK channels are internalized from the plasma membrane via a clathrin-dependent pathway.[16][17] This process is stimulated by signals such as low dietary potassium, which activates PTKs and WNK kinases.[1][16] The internalization of ROMK involves a specific motif in its C-terminus and is dependent on dynamin.[17][18]

Other Regulatory Factors

- Phosphatidylinositol 4,5-bisphosphate (PIP2): PIP2, a membrane phospholipid, is essential for the activity of ROMK and other Kir channels.[1] It directly interacts with the channel to maintain it in an open state.[19] Hormones and signaling pathways that lead to PIP2 hydrolysis can therefore inhibit ROMK activity.[1]
- Intracellular pH: As noted, ROMK channels are highly sensitive to intracellular pH, with acidification causing a sharp decrease in channel activity.[12] This provides a mechanism to link renal potassium handling with systemic acid-base status.
- Intracellular ATP: High levels of intracellular ATP can inhibit ROMK, linking channel activity to the metabolic state of the cell. This inhibition is particularly evident when ROMK is co-expressed with the cystic fibrosis transmembrane conductance regulator (CFTR).[1][4]

Signaling Pathways and Regulatory Networks

The regulation of ROMK is best understood as a series of interconnected signaling pathways that converge on the channel to modulate its function.

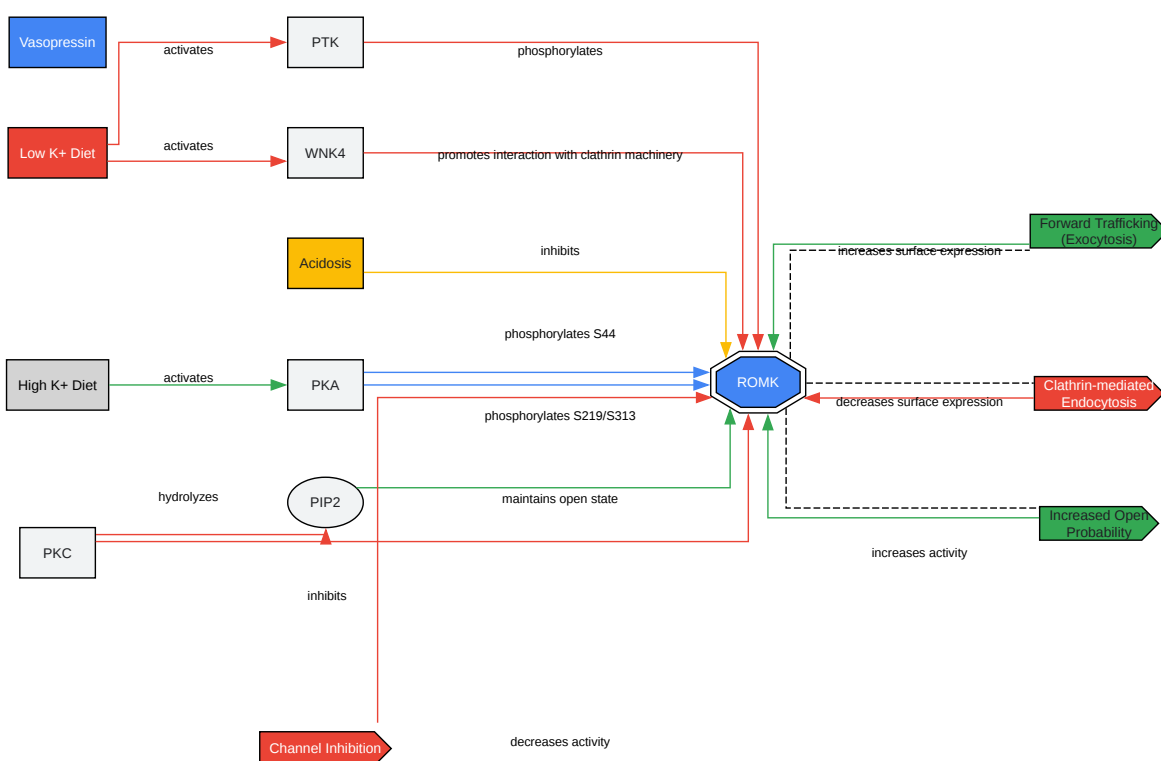
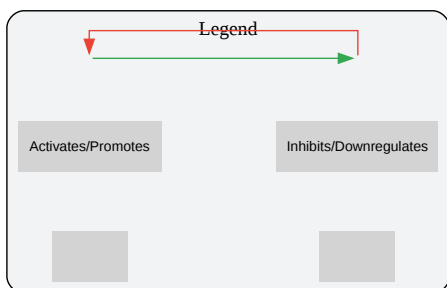

[Click to download full resolution via product page](#)

Diagram of key signaling pathways regulating ROMK channel activity.

Experimental Protocols

Studying ROMK channels requires a combination of molecular, biochemical, and electrophysiological techniques. Below are outlines of key experimental protocols.

Patch-Clamp Electrophysiology for Measuring ROMK Activity

This technique allows for the direct measurement of ion flow through ROMK channels in the cell membrane.

Objective: To measure whole-cell or single-channel ROMK currents in native renal tubules or heterologous expression systems (e.g., *Xenopus* oocytes, mammalian cell lines).

Methodology:

- Cell/Tubule Preparation:
 - For native tubules: Kidneys are harvested, and specific segments (e.g., CCD) are microdissected. The tubules are then split open to allow access to the apical membrane. [\[20\]](#)
 - For expression systems: Cells are cultured on coverslips and transfected with ROMK-encoding plasmids.
- Pipette and Solution Preparation:
 - Pipette Solution (intracellular): Typically contains (in mM): 130 KCl, 10 HEPES, 2 EGTA, 1 MgCl₂, adjusted to pH 7.4 with KOH. ATP and GTP may be included to mimic intracellular conditions. [\[20\]](#)
 - Bath Solution (extracellular): Typically contains (in mM): 140 NaCl, 5 KCl, 1 CaCl₂, 1 MgCl₂, 10 HEPES, 5 Glucose, adjusted to pH 7.4 with NaOH.
- Gigaohm Seal Formation: A glass micropipette with a tip diameter of ~1 μm is pressed against the cell membrane. Gentle suction is applied to form a high-resistance (>1 GΩ) seal.
- Configuration:

- Cell-Attached: The membrane patch remains intact, allowing for the study of channel activity in a near-physiological state.
- Inside-Out: The patch is excised from the cell, exposing the intracellular face of the membrane to the bath solution. This is ideal for studying the effects of intracellular modulators (e.g., ATP, pH, kinases).[19]
- Whole-Cell: The membrane patch is ruptured, allowing for the measurement of the total current from all channels on the cell surface.
- Data Acquisition and Analysis:
 - A voltage-clamp protocol is applied to the membrane. For ROMK, this often involves a series of voltage steps or ramps to generate a current-voltage (I-V) relationship.
 - ROMK-mediated currents can be identified by their characteristic biophysical properties (e.g., weak inward rectification) and by their sensitivity to specific blockers like Tertiapin-Q or barium.[21]
 - Software is used to analyze current amplitude, open probability (for single-channel recordings), and conductance.

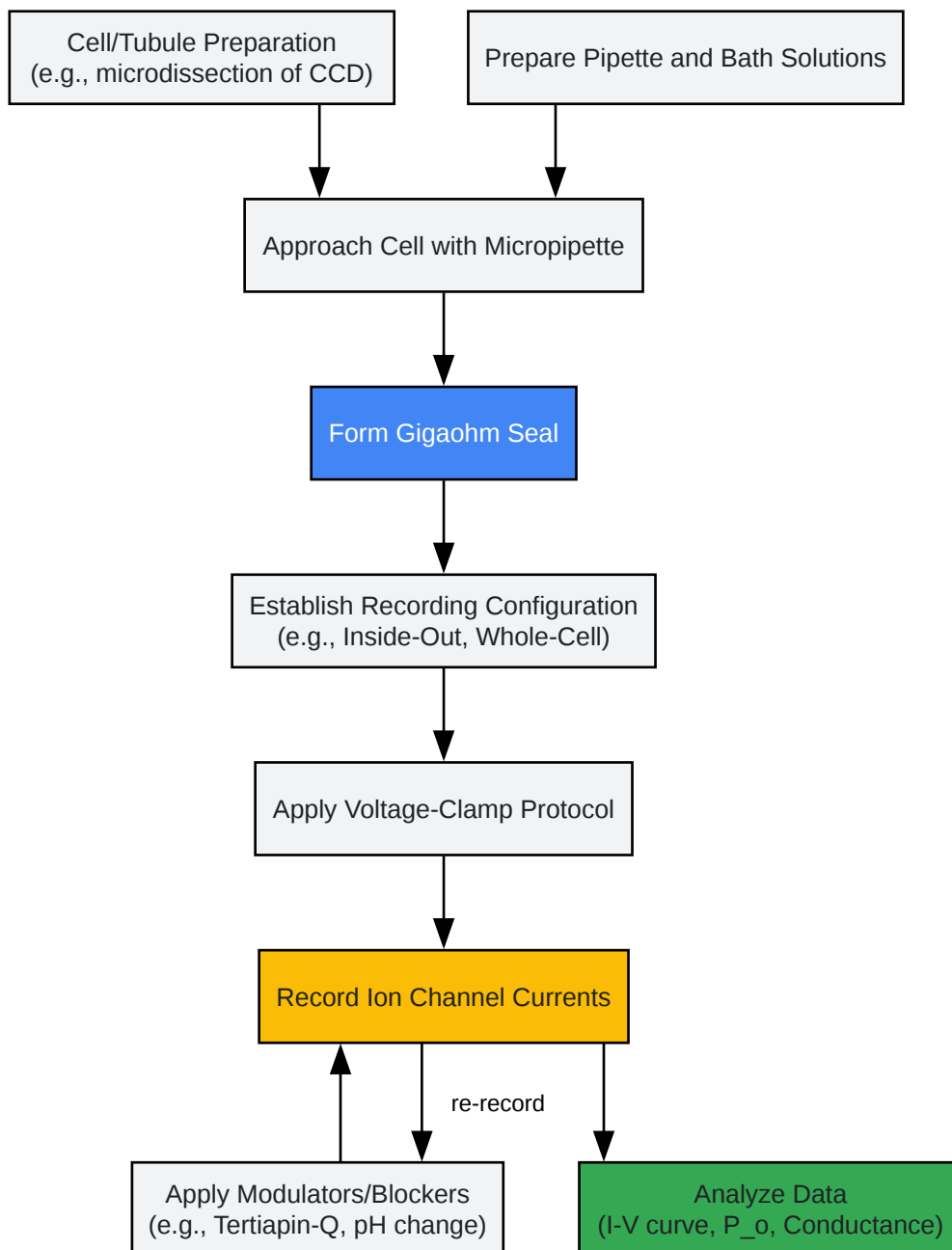

[Click to download full resolution via product page](#)

A simplified workflow for patch-clamp analysis of ROMK channels.

Immunoblotting and Immunofluorescence for ROMK Expression and Localization

These techniques are used to assess the total amount of ROMK protein and its subcellular localization.

Objective: To quantify changes in total and cell-surface ROMK protein levels in response to various stimuli (e.g., changes in dietary potassium).

Methodology:

- Tissue/Cell Lysis: Kidneys or cultured cells are homogenized in a lysis buffer containing detergents and protease/phosphatase inhibitors to extract total protein.
- Surface Biotinylation (for surface protein analysis):
 - Intact cells or tissues are incubated with a membrane-impermeable biotin reagent that labels primary amines of extracellular domains of surface proteins.
 - The reaction is quenched, and cells are lysed.
 - Biotinylated proteins are captured using streptavidin-coated beads.
 - The captured proteins (surface fraction) and the unbound proteins (intracellular fraction) are analyzed separately.
- SDS-PAGE and Western Blotting:
 - Protein samples are separated by size using sodium dodecyl sulfate-polyacrylamide gel electrophoresis (SDS-PAGE).
 - Proteins are transferred to a nitrocellulose or PVDF membrane.
 - The membrane is incubated with a primary antibody specific for ROMK.
 - A secondary antibody conjugated to an enzyme (e.g., HRP) is added, which binds to the primary antibody.
 - A chemiluminescent substrate is applied, and the resulting light signal is captured on film or with a digital imager. The band intensity corresponds to the amount of ROMK protein.
- Immunofluorescence and Confocal Microscopy:
 - Kidney sections or cultured cells are fixed and permeabilized.

- Samples are incubated with a primary ROMK antibody, followed by a fluorescently labeled secondary antibody.
- Nuclei are often counterstained with a DNA-binding dye like DAPI.
- Samples are imaged using a confocal microscope to determine the subcellular localization of ROMK (e.g., apical membrane vs. intracellular compartments).

ROMK as a Therapeutic Target

The critical role of ROMK in the TAL, where it supports the function of the NKCC2 cotransporter (the target of loop diuretics like furosemide), makes it an attractive target for a new class of diuretics.[7][22] Inhibiting ROMK is expected to reduce sodium reabsorption in the TAL, leading to diuresis and natriuresis.[23] A potential advantage of ROMK inhibitors over traditional loop diuretics is their potential to be potassium-sparing. By also inhibiting ROMK in the CCD, these drugs could simultaneously block the primary route of potassium secretion, thereby mitigating the risk of hypokalemia, a common side effect of loop and thiazide diuretics.[3][23] Several small molecule inhibitors of ROMK have been developed and are under investigation for the treatment of hypertension and heart failure.[7]

Conclusion

The ROMK channel is a central player in renal physiology, essential for maintaining salt and potassium balance. Its activity is finely tuned by a complex interplay of signaling pathways that regulate its phosphorylation state, trafficking, and gating. Understanding these mechanisms has not only illuminated fundamental principles of kidney function but has also paved the way for the development of novel therapeutic strategies targeting ROMK for cardiovascular and renal diseases. The experimental approaches detailed in this guide provide the foundation for continued research into this vital ion channel.

Need Custom Synthesis?

BenchChem offers custom synthesis for rare earth carbides and specific isotopic labeling.

Email: info@benchchem.com or [Request Quote Online](#).

References

- [1. A comprehensive guide to the ROMK potassium channel: form and function in health and disease - PMC \[pmc.ncbi.nlm.nih.gov\]](#)
- [2. ROMK - Wikipedia \[en.wikipedia.org\]](#)
- [3. pubs.acs.org \[pubs.acs.org\]](#)
- [4. journals.physiology.org \[journals.physiology.org\]](#)
- [5. Bartter Syndrome - StatPearls - NCBI Bookshelf \[ncbi.nlm.nih.gov\]](#)
- [6. Bartter Syndrome: Practice Essentials, Pathophysiology, Etiology \[medicine.medscape.com\]](#)
- [7. scilit.com \[scilit.com\]](#)
- [8. researchgate.net \[researchgate.net\]](#)
- [9. Genetic heterogeneity of Bartter's syndrome revealed by mutations in the K⁺ channel, ROMK - PubMed \[pubmed.ncbi.nlm.nih.gov\]](#)
- [10. Renal outer medullary potassium channel knockout models reveal thick ascending limb function and dysfunction - PubMed \[pubmed.ncbi.nlm.nih.gov\]](#)
- [11. Absence of small conductance K⁺ channel \(SK\) activity in apical membranes of thick ascending limb and cortical collecting duct in ROMK \(Bartter's\) knockout mice - PubMed \[pubmed.ncbi.nlm.nih.gov\]](#)
- [12. Regulation of Kir Channels by Intracellular pH and Extracellular K⁺ : Mechanisms of Coupling - PMC \[pmc.ncbi.nlm.nih.gov\]](#)
- [13. journals.physiology.org \[journals.physiology.org\]](#)
- [14. academic.oup.com \[academic.oup.com\]](#)
- [15. Regulation of ROMK channels by protein tyrosine kinase and tyrosine phosphatase - PubMed \[pubmed.ncbi.nlm.nih.gov\]](#)
- [16. journals.physiology.org \[journals.physiology.org\]](#)
- [17. Evidence for endocytosis of ROMK potassium channel via clathrin-coated vesicles - PubMed \[pubmed.ncbi.nlm.nih.gov\]](#)
- [18. researchgate.net \[researchgate.net\]](#)
- [19. Characterization of hyperactive mutations in the renal potassium channel ROMK uncovers unique effects on channel biogenesis and ion conductance - PMC \[pmc.ncbi.nlm.nih.gov\]](#)
- [20. Magnesium Modulates ROMK Channel–Mediated Potassium Secretion - PMC \[pmc.ncbi.nlm.nih.gov\]](#)

- [21. rupress.org \[rupress.org\]](https://rupress.org)
- [22. The Renal Outer Medullary Potassium Channel \(ROMK\): An Intriguing Pharmacological Target for an Innovative Class of Diuretic Drugs - PubMed \[pubmed.ncbi.nlm.nih.gov\]](https://pubmed.ncbi.nlm.nih.gov)
- [23. Pharmacologic inhibition of the renal outer medullary potassium channel causes diuresis and natriuresis in the absence of kaliuresis - PubMed \[pubmed.ncbi.nlm.nih.gov\]](https://pubmed.ncbi.nlm.nih.gov)
- To cite this document: BenchChem. [The Role of ROMK Channels in Renal Physiology: A Technical Guide]. BenchChem, [2026]. [Online PDF]. Available at: [\[https://www.benchchem.com/product/b10768957/docs#the-role-of-romk-channels-in-renal-physiology-a-technical-guide\]](https://www.benchchem.com/product/b10768957/docs#the-role-of-romk-channels-in-renal-physiology-a-technical-guide)

Disclaimer & Data Validity:

The information provided in this document is for Research Use Only (RUO) and is strictly not intended for diagnostic or therapeutic procedures. While BenchChem strives to provide accurate protocols, we make no warranties, express or implied, regarding the fitness of this product for every specific experimental setup.

Technical Support: The protocols provided are for reference purposes. Unsure if this reagent suits your experiment?

Need Industrial/Bulk Grade? [Request Custom Synthesis Quote](#)

BenchChem

Our mission is to be the trusted global source of essential and advanced chemicals, empowering scientists and researchers to drive progress in science and industry.

Contact

Address: 3281 E Guasti Rd
Ontario, CA 91761, United States
Phone: (601) 213-4426
Email: info@benchchem.com

Contact our Ph.D. Support Team for a compatibility check