

Technical Support Center: AM3102 Batch Assessment

Author: BenchChem Technical Support Team. **Date:** April 2026

Compound of Interest

Compound Name:	AM3102
CAS No.:	45279-84-3
Cat. No.:	B10768027

[Get Quote](#)

For Researchers, Scientists, and Drug Development Professionals

An Important Clarification on the Nature of **AM3102**

It has come to our attention that there may be a misunderstanding regarding the nature of **AM3102**. **AM3102** is not a small molecule, chemical compound, or drug substance. Instead, it is a miniature, digitally tunable bandpass filter integrated circuit (IC). Therefore, traditional methods of chemical purity assessment, such as chromatography or spectroscopy, are not applicable.

Assessing a new batch of **AM3102** integrated circuits involves verifying their electrical performance and ensuring they meet the manufacturer's specifications. This guide provides the necessary information and procedures to perform a quality assessment of a new batch of **AM3102** components.

Frequently Asked Questions (FAQs)

Q1: What is **AM3102**?

A1: **AM3102** is a digitally tunable bandpass filter integrated circuit (IC). It is designed to allow signals within a specific frequency range to pass through while blocking frequencies outside that range. The key feature of the **AM3102** is that its center frequency and bandwidth can be adjusted electronically.

Q2: How is the "purity" of an **AM3102** batch determined?

A2: For an integrated circuit like **AM3102**, "purity" is analogous to quality and performance consistency. A "pure" or high-quality batch will have all units performing within the electrical specifications defined in the manufacturer's datasheet. Assessment involves testing key RF performance parameters.

Q3: What key parameters should be tested to ensure the quality of a new batch?

A3: Key parameters to test include insertion loss, return loss, center frequency and bandwidth tuning accuracy, and rejection levels. These parameters ensure the filter is performing its function correctly and efficiently within the system.

Q4: What equipment is necessary for testing **AM3102**?

A4: To test the RF performance of the **AM3102**, you will need a Vector Network Analyzer (VNA). A VNA can measure parameters like insertion loss (S21) and return loss (S11) across the operating frequency range. You will also need a DC power supply and a method to send digital control signals to the **AM3102** to tune the filter.

Q5: What are some common failure modes for a batch of tunable filters?

A5: Common issues can include a shift in the frequency response, higher than specified insertion loss, or a failure of the digital tuning mechanism. These can be caused by manufacturing defects or damage during handling.

Troubleshooting Guide

Issue	Possible Cause	Troubleshooting Steps
No signal output	Incorrect power supply voltage or no power.	Verify the DC power supply is connected correctly and providing the specified voltage.
Incorrect input/output connections.	Check that the RF input and output are connected to the correct pins and that all connections are secure.	
Filter is not tuning to the correct frequency	Incorrect digital control signals.	Verify the logic levels and timing of the digital control signals being sent to the filter's control pins.
Faulty digital control lines.	Check for shorts or open circuits on the control lines.	
High insertion loss	Impedance mismatch.	Ensure the input and output impedances are matched to the test equipment (typically 50 ohms).
Damaged component.	The individual IC may be damaged and should be replaced.	
Poor rejection of out-of-band signals	The filter is not tuned correctly.	Re-verify the digital control signals for the desired passband.
The performance is outside of specification.	If the tuning is correct, the component may not be meeting its specified rejection performance.	

AM3102 Key Performance Parameters

The following table summarizes the key electrical characteristics for the **AM3102** digitally tunable bandpass filter. A new batch should be tested to ensure these specifications are met.

Parameter	Specification	Description
Frequency Range	330 MHz to 1.2 GHz (or 450 MHz to 1.5 GHz)	The range of frequencies over which the filter can be tuned.
Insertion Loss	2.5 dB (typical)	The amount of signal power lost as it passes through the filter.
Rejection	40 dB (typical)	The amount of attenuation of signals outside the passband.
Digital Control	Independent 4-bit control for low-pass and high-pass corners	Allows for adjustment of both center frequency and bandwidth.
Package	4mm x 6mm QFN	The physical package of the integrated circuit.

Experimental Protocols

Protocol 1: Measurement of Insertion Loss (S21) and Return Loss (S11)

Objective: To measure the filter's passband performance and impedance match.

Equipment:

- Vector Network Analyzer (VNA)
- DC Power Supply
- Digital Control Source (e.g., microcontroller, FPGA)
- **AM3102** Evaluation Board or custom test fixture
- RF cables and connectors

Procedure:

- Calibration: Perform a full two-port calibration of the VNA over the frequency range of interest (e.g., 300 MHz to 1.6 GHz).
- Setup: Connect the **AM3102** test fixture to the VNA ports. Connect the DC power supply and the digital control source to the **AM3102**.
- Power On: Apply the recommended DC voltage to the **AM3102**.
- Tuning: Program the **AM3102** to a specific center frequency and bandwidth using the digital control lines.
- Measurement: Use the VNA to measure the S21 (insertion loss) and S11 (return loss) across the calibrated frequency range.
- Analysis: Record the insertion loss at the center frequency and the maximum return loss within the passband.
- Repeat: Repeat steps 4-6 for several different tuning settings to verify performance across the operating range.

Visualizations

AM3102 Batch Assessment Workflow

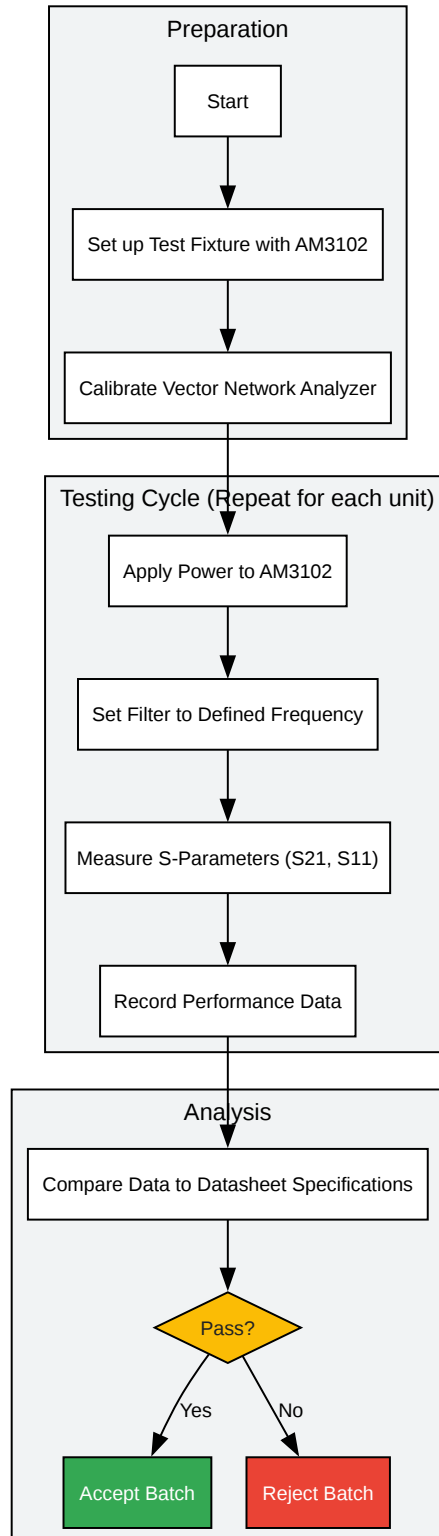

Troubleshooting High Insertion Loss

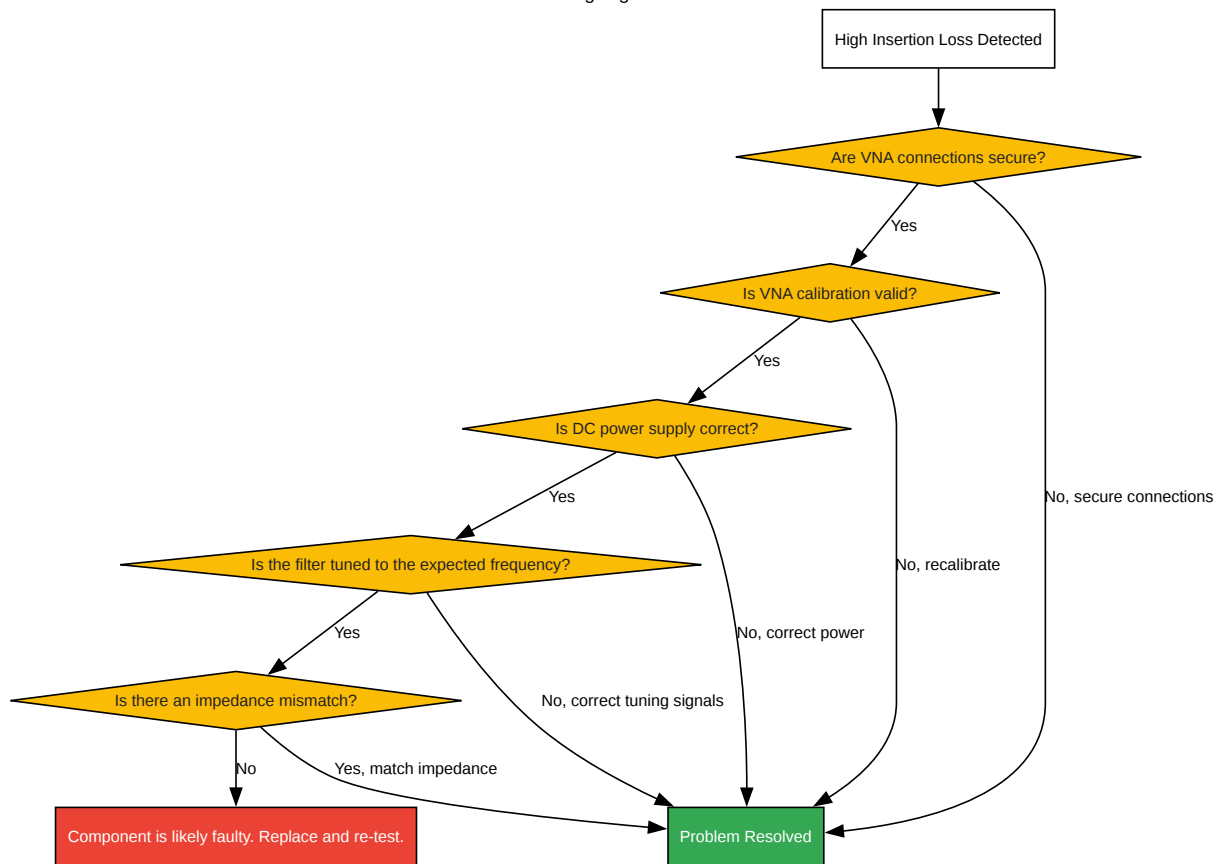

[Click to download full resolution via product page](#)

- To cite this document: BenchChem. [Technical Support Center: AM3102 Batch Assessment]. BenchChem, [2026]. [Online PDF]. Available at: [\[https://www.benchchem.com/product/b10768027/docs#technical-support-center-am3102-batch-assessment\]](https://www.benchchem.com/product/b10768027/docs#technical-support-center-am3102-batch-assessment)

Disclaimer & Data Validity:

The information provided in this document is for Research Use Only (RUO) and is strictly not intended for diagnostic or therapeutic procedures. While BenchChem strives to provide accurate protocols, we make no warranties, express or implied, regarding the fitness of this product for every specific experimental setup.

Technical Support: The protocols provided are for reference purposes. Unsure if this reagent suits your experiment?

Need Industrial/Bulk Grade? [Request Custom Synthesis Quote](#)

BenchChem

Our mission is to be the trusted global source of essential and advanced chemicals, empowering scientists and researchers to drive progress in science and industry.

Contact

Address: 3281 E Guasti Rd
Ontario, CA 91761, United States
Phone: (601) 213-4426
Email: info@benchchem.com

[Contact our Ph.D. Support Team for a compatibility check](#)