

SR59230A Hydrochloride: A Comprehensive Technical Guide

Author: BenchChem Technical Support Team. **Date:** April 2026

Compound of Interest

Compound Name: SR59230A hydrochloride

Cat. No.: B10768395

[Get Quote](#)

For Researchers, Scientists, and Drug Development Professionals

This in-depth technical guide provides a comprehensive overview of **SR59230A hydrochloride**, a potent and selective β 3-adrenergic receptor antagonist. This document details its chemical properties, mechanism of action, key signaling pathways, and established experimental protocols, serving as a vital resource for professionals in drug discovery and development.

Core Compound Specifications

SR59230A hydrochloride is a well-characterized molecule with specific physical and chemical properties crucial for experimental design and execution.

Property	Value	Citation(s)
CAS Number	1135278-41-9	[1][2][3]
Molecular Weight	361.91 g/mol	[1][2][3]
Molecular Formula	C ₂₁ H ₂₈ ClNO ₂	[2][3]
Purity	≥98%	[2][4]
Appearance	White to off-white solid	[2]
Solubility	Soluble in water to 10 mM and in DMSO to 100 mM.	[3][4]
Storage	Store at room temperature. For stock solutions, store at -20°C for up to 1 month or -80°C for up to 6 months.	[4][5]

Mechanism of Action and Pharmacological Profile

SR59230A hydrochloride is primarily recognized as a potent and selective antagonist of the β 3-adrenergic receptor.[1] Its selectivity for the β 3 receptor over β 1 and β 2 receptors makes it a valuable tool for investigating the physiological and pathological roles of the β 3-adrenoceptor.

The antagonist activity of **SR59230A hydrochloride** has been demonstrated through its ability to block the effects of β 3-adrenergic agonists. However, it's important to note that at higher concentrations, **SR59230A hydrochloride** can also exhibit antagonist activity at α 1-adrenoceptors, a factor that should be considered in experimental design.[1]

Interestingly, **SR59230A hydrochloride** also displays characteristics of "ligand-directed signaling" or "biased agonism." This means that while it acts as an antagonist at the canonical Gs-cAMP signaling pathway, it can simultaneously act as a partial or full agonist at other signaling pathways, such as the p38 MAPK and Erk1/2 pathways. This pleiotropic activity is dependent on the cell type and the level of receptor expression.

The IC₅₀ values of **SR59230A hydrochloride** highlight its selectivity profile:

Receptor	IC ₅₀ (nM)	Citation(s)
β3-adrenergic	40	[1]
β1-adrenergic	408	[1]
β2-adrenergic	648	[1]

Key Signaling Pathways

The interaction of **SR59230A hydrochloride** with the β3-adrenergic receptor modulates several key intracellular signaling cascades. Understanding these pathways is critical for interpreting experimental results.

β3-Adrenergic Receptor Antagonism and cAMP Pathway

As a β3-adrenergic receptor antagonist, **SR59230A hydrochloride** primarily blocks the Gs protein-mediated activation of adenylyl cyclase, leading to a decrease in intracellular cyclic AMP (cAMP) levels. This is the canonical pathway for β3-adrenergic receptor signaling.

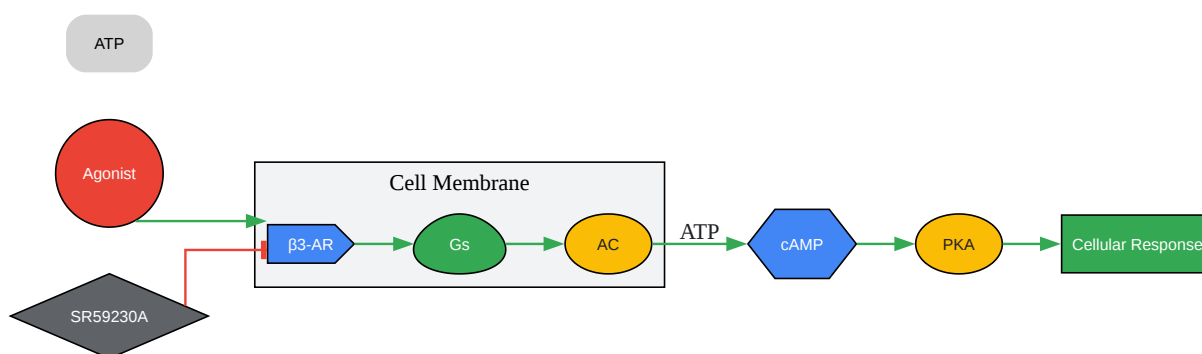

[Click to download full resolution via product page](#)

Caption: Antagonism of the Gs-cAMP pathway by **SR59230A hydrochloride**.

Ligand-Directed Signaling: p38 MAPK and Erk1/2 Pathways

SR59230A hydrochloride can paradoxically activate the p38 MAPK and Erk1/2 signaling pathways, demonstrating biased agonism. This activation is independent of the Gs-cAMP pathway and is thought to be mediated through G protein-coupled receptor kinases (GRKs) and β -arrestins.

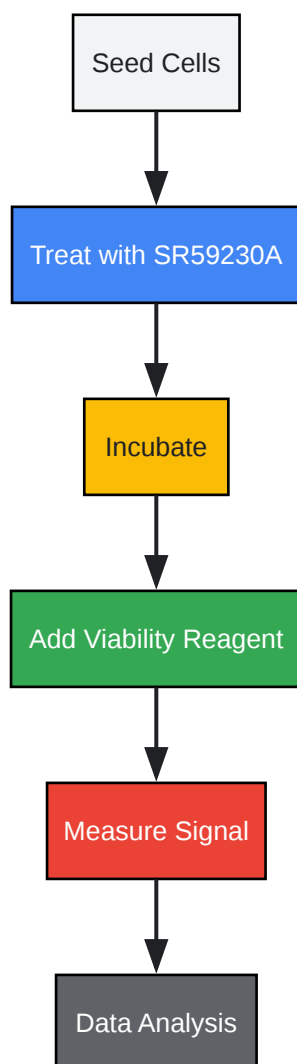
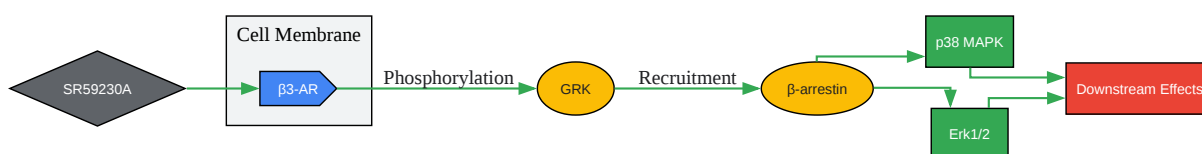

[Click to download full resolution via product page](#)

Need Custom Synthesis?

BenchChem offers custom synthesis for rare earth carbides and specific isotopic labeling.

Email: info@benchchem.com or [Request Quote Online](#).

References

- [1. medkoo.com \[medkoo.com\]](#)
- [2. xcessbio.com \[xcessbio.com\]](#)
- [3. rndsystems.com \[rndsystems.com\]](#)
- [4. SR 59230A hydrochloride | Adrenergic \$\beta\$ 3 Receptors | Tocris Bioscience \[tocris.com\]](#)
- [5. medchemexpress.com \[medchemexpress.com\]](#)
- To cite this document: BenchChem. [SR59230A Hydrochloride: A Comprehensive Technical Guide]. BenchChem, [2026]. [Online PDF]. Available at: [\[https://www.benchchem.com/product/b10768395/docs#sr59230a-hydrochloride-a-comprehensive-technical-guide\]](https://www.benchchem.com/product/b10768395/docs#sr59230a-hydrochloride-a-comprehensive-technical-guide)

Disclaimer & Data Validity:

The information provided in this document is for Research Use Only (RUO) and is strictly not intended for diagnostic or therapeutic procedures. While BenchChem strives to provide accurate protocols, we make no warranties, express or implied, regarding the fitness of this product for every specific experimental setup.

Technical Support: The protocols provided are for reference purposes. Unsure if this reagent suits your experiment?

Need Industrial/Bulk Grade? [Request Custom Synthesis Quote](#)

BenchChem

Our mission is to be the trusted global source of essential and advanced chemicals, empowering scientists and researchers to drive progress in science and industry.

Contact

Address: 3281 E Guasti Rd

Ontario, CA 91761, United States

Phone: (601) 213-4426

Email: info@benchchem.com

[Contact our Ph.D. Support Team for a compatibility check](#)