

Prototyping with the AM3102 Evaluation Board: An Application Note

Author: BenchChem Technical Support Team. **Date:** April 2026

Compound of Interest

Compound Name: AM3102
Cat. No.: B10768044

[Get Quote](#)

For Researchers, Scientists, and Drug Development Professionals

Introduction

In modern research and development environments, particularly in fields such as drug discovery and biomedical engineering, the ability to rapidly prototype and test novel electronic systems is paramount. The **AM3102** evaluation board provides a platform for working with a digitally tunable bandpass filter, operating in the 330 MHz to 1.2 GHz frequency range.[1] This component is particularly useful in the development of custom scientific instrumentation that requires precise frequency selectivity to enhance signal-to-noise ratios in spectrally crowded environments.

This application note serves as a comprehensive guide for researchers, scientists, and drug development professionals on utilizing the **AM3102** evaluation board for prototyping applications. It provides detailed protocols for board setup, filter characterization, and a practical example of its use in a laboratory setting.

AM3102 Evaluation Board Overview

The **AM3102** is a digitally tunable bandpass filter that allows for independent control of its low-pass and high-pass corners through a 4-bit digital interface for each.[1] This enables dynamic adjustment of the filter's center frequency and bandwidth. The evaluation board is equipped with SMA connectors for RF input and output, and a DIP switch for manual control of the filter settings.

Key Specifications

Parameter	Value
Frequency Range	330 MHz to 1.2 GHz
Control Interface	2 x 4-bit Digital Control (High-Pass and Low-Pass)
Insertion Loss	~2.5 dB
Package (IC)	4x6mm QFN
Supply Voltage	+3.3V to +5.0V

Experimental Protocols

Protocol 1: Basic Characterization of the AM3102 Evaluation Board

Objective: To familiarize the user with the operation of the **AM3102** evaluation board and to measure the filter's frequency response for a given set of control inputs.

Materials:

- **AM3102** Evaluation Board
- Vector Network Analyzer (VNA) or a Signal Generator and a Spectrum Analyzer
- 5V DC Power Supply
- SMA Cables (2)

Procedure:

- Board Setup:
 - Connect the 5V DC power supply to the designated power input on the **AM3102** evaluation board.
 - Connect the RF input of the evaluation board to the output port of the signal generator (or Port 1 of the VNA) using an SMA cable.
 - Connect the RF output of the evaluation board to the input of the spectrum analyzer (or Port 2 of the VNA) using another SMA cable.

- Filter Configuration:
 - The **AM3102** evaluation board is equipped with a DIP switch for manual control of the high-pass and low-pass filter settings. Each filter has a 4-bit control word.
 - Refer to the control tables below (Tables 3.1 and 3.2) to determine the DIP switch settings for the desired cutoff frequencies.
 - For an initial test, set the High-Pass filter to a low-frequency setting (e.g., 330 MHz) and the Low-Pass filter to a high-frequency setting (e.g., 1200 MHz) to create a wide passband.

- Measurement:
 - Turn on the DC power supply.
 - Using a VNA:
 - Perform a 2-port calibration of the VNA.
 - Measure the S21 parameter (insertion loss) of the **AM3102** evaluation board from 100 MHz to 1.5 GHz.
 - Using a Signal Generator and Spectrum Analyzer:
 - Set the signal generator to sweep the frequency range from 100 MHz to 1.5 GHz with a constant output power (e.g., 0 dBm).

- Set the spectrum analyzer to the same frequency range and record the output power at the RF output of the evaluation board.
- The insertion loss can be calculated by subtracting the measured output power from the input power.
- Data Analysis:
 - Plot the insertion loss as a function of frequency.
 - Identify the -3dB cutoff frequencies for the high-pass and low-pass filters.
 - Compare the measured cutoff frequencies with the values in the control tables.

Protocol 2: Application in a Wireless Sensing System

Objective: To demonstrate the use of the **AM3102** evaluation board to isolate a specific frequency band in a prototype wireless sensing application, thereby improving signal reception in the presence of interference.

Materials:

- **AM3102** Evaluation Board
- Two software-defined radios (SDRs) or a signal generator and a receiver
- Antennas appropriate for the operating frequency
- 5V DC Power Supply
- SMA Cables

Procedure:

- System Setup:
 - Configure one SDR (or signal generator) to transmit a modulated signal at a specific frequency within the **AM3102**'s range (e.g., 915 MHz). This will simulate the signal from a wireless sensor.

- Configure the second SDR (or another signal generator) to transmit a continuous wave (CW) or modulated signal at a nearby frequency that will act as an interferer (e.g., 900 MHz).
- Connect the receiving antenna to the RF input of the **AM3102** evaluation board.
- Connect the RF output of the **AM3102** evaluation board to the input of the receiving SDR.
- Initial Measurement (Without Filtering):
 - Initially, bypass the **AM3102** evaluation board and connect the receiving antenna directly to the receiver.
 - Observe the received spectrum. Note the presence of both the desired signal at 915 MHz and the interfering signal at 900 MHz.
 - Attempt to demodulate the desired signal and note the signal-to-noise ratio (SNR) or bit error rate (BER).
- Filtering and Measurement:
 - Insert the **AM3102** evaluation board into the receive path as described in the system setup.
 - Using the control tables, set the DIP switches on the evaluation board to create a passband that includes the desired signal but attenuates the interfering signal. For example, set the high-pass filter to approximately 910 MHz and the low-pass filter to approximately 920 MHz.
 - Observe the received spectrum again. The interfering signal at 900 MHz should be significantly attenuated.
 - Attempt to demodulate the desired signal again and note the improvement in SNR or BER.

Quantitative Data

The following tables provide the relationship between the 4-bit digital control words and the typical cutoff frequencies for the high-pass and low-pass filters of the **AM3102**.

Table 3.1: High-Pass Filter Control

Control Word (D C B A)	Typical Cutoff Frequency (MHz)
L L L L	330
L L L H	332
L L H L	338
L L H H	341
L H L L	370
L H L H	375
L H H L	385
L H H H	390
H L L L	450
H L L H	460
H L H L	475
H L H H	485
H H L L	580
H H L H	600
H H H L	640
H H H H	670

Data sourced from the **AM3102** datasheet.[\[1\]](#)

Table 3.2: Low-Pass Filter Control

Control Word (H G F E)	Typical Cutoff Frequency (MHz)
LLLL	450
LLLH	460
LLHL	475
LLHH	485
LHLL	580
LHLH	600
LHHL	640
LHHH	670
HLLL	800
HLLH	830
HLHL	870
HLHH	900
HHLL	1000
HHLH	1050
HHHL	1150
HHHH	1200

Data sourced from the **AM3102** datasheet.[\[1\]](#)

Visualizations

Experimental Workflow for Filter Characterization

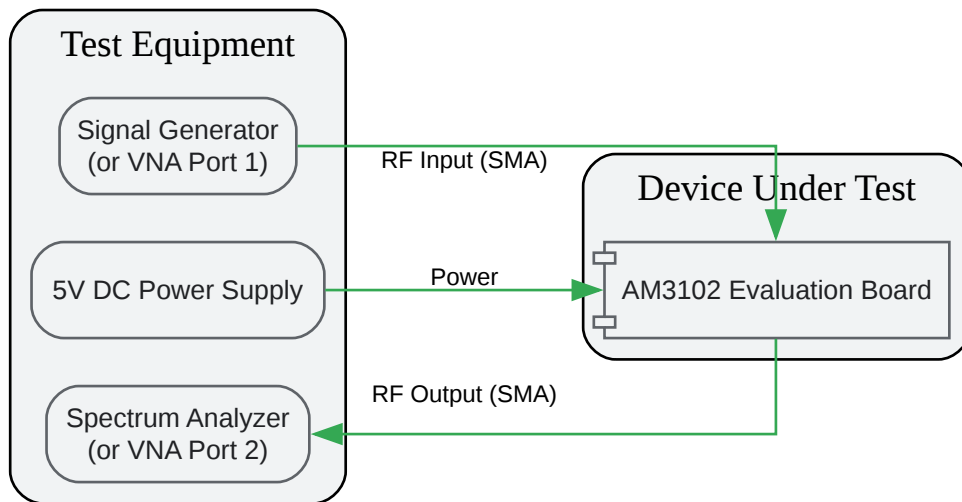

[Click to download full resolution via product page](#)

Figure 1: Experimental setup for characterizing the **AM3102** evaluation board.

Digital Control Logic for Passband Selection

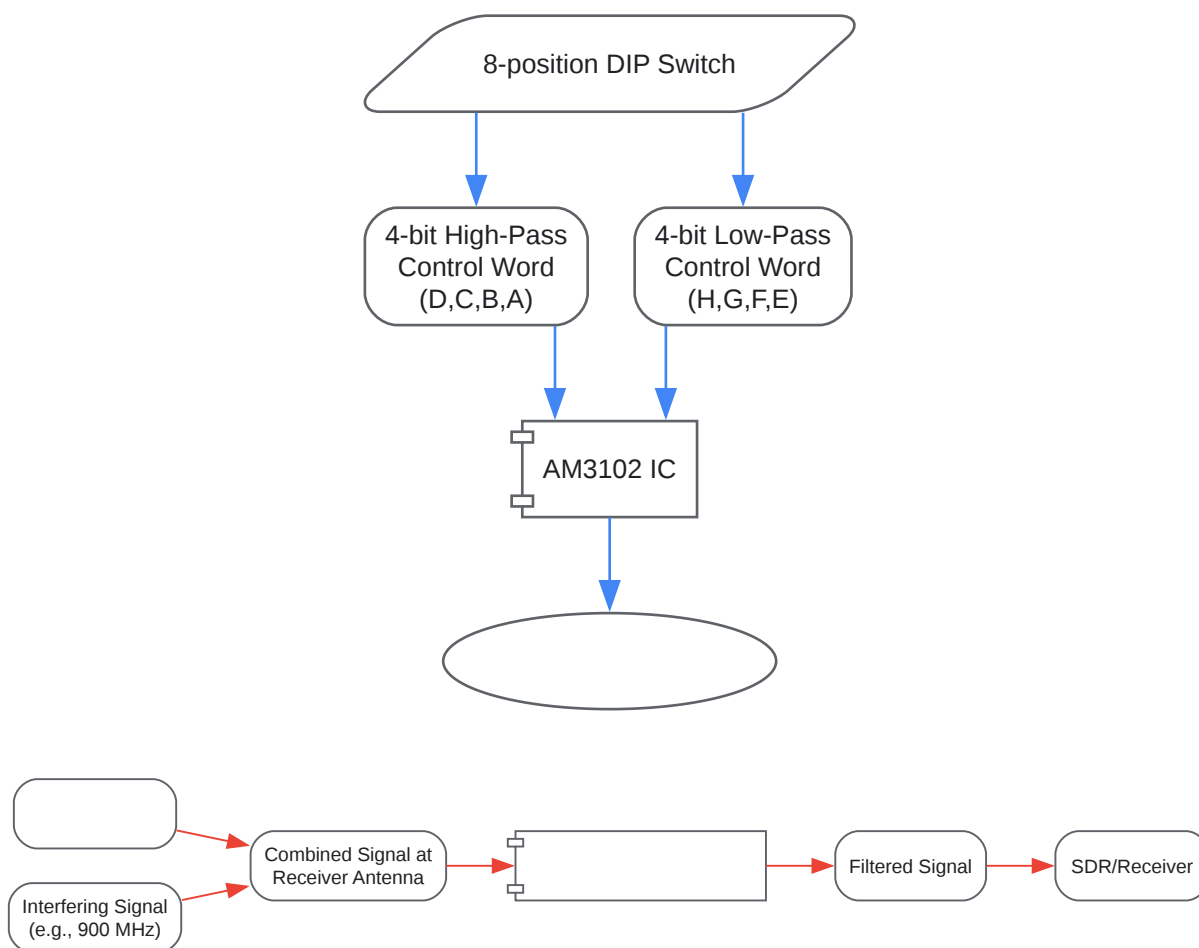

[Click to download full resolution via product page](#)

Need Custom Synthesis?

BenchChem offers custom synthesis for rare earth carbides and specific isotopic labeling.

Email: info@benchchem.com or [Request Quote Online](#).

References

- 1. [AM3102 Tunable MMIC Filter | Mercury Systems \[mrcy.com\]](#)
- To cite this document: BenchChem. [Prototyping with the AM3102 Evaluation Board: An Application Note]. BenchChem, [2026]. [Online PDF]. Available at: [\[https://www.benchchem.com/product/b10768044/docs#prototyping-with-the-am3102-evaluation-board-an-application-note\]](https://www.benchchem.com/product/b10768044/docs#prototyping-with-the-am3102-evaluation-board-an-application-note)

Disclaimer & Data Validity:

The information provided in this document is for Research Use Only (RUO) and is strictly not intended for diagnostic or therapeutic procedures. While BenchChem strives to provide accurate protocols, we make no warranties, express or implied, regarding the fitness of this product for every specific experimental setup.

Technical Support: The protocols provided are for reference purposes. Unsure if this reagent suits your experiment?

Need Industrial/Bulk Grade? [Request Custom Synthesis Quote](#)

BenchChem

Our mission is to be the trusted global source of essential and advanced chemicals, empowering scientists and researchers to drive progress in science and industry.

Contact

Address: 3281 E Guasti Rd
Ontario, CA 91761, United States
Phone: (601) 213-4426
Email: info@benchchem.com

[Contact our Ph.D. Support Team for a compatibility check](#)