

G-1 Dosage and Administration in Mouse Models: Application Notes and Protocols

Author: BenchChem Technical Support Team. **Date:** April 2026

Compound of Interest

Compound Name: (3aS,4R,9bR)-G-1

CAS No.: 925419-55-2

Cat. No.: B10768565

[Get Quote](#)

For Researchers, Scientists, and Drug Development Professionals

This document provides detailed application notes and protocols for the use of G-1, a selective G protein-coupled estrogen receptor (GPER) agonist, in mouse models. It summarizes quantitative data on dosage and administration and provides structured experimental protocols for key research areas.

Data Presentation: G-1 Dosage and Administration Summary

The following table summarizes the reported dosages and administration routes for G-1 in various mouse models. This information is intended to serve as a starting point for experimental design. Researchers should optimize the dosage and administration for their specific mouse strain and experimental context.

Application	Mouse Model	Dosage	Administration Route	Frequency	Vehicle	Observed Effects	Citation
Obesity & Diabetes	Ovariectomized (OVX) female mice	200 µg per mouse	Subcutaneous (s.c.)	5 days/week for 8 weeks	Ethanol diluted in vehicle	Reduced body weight, improved glucose homeostasis, increased energy expenditure.	[1][2]
Obesity & Diabetes	Diet-induced obesity (DIO) male mice	200 µg per mouse	Subcutaneous (s.c.)	5 days/week for 8 weeks	Ethanol diluted in vehicle	Prevented further weight gain, improved glucose tolerance.	[1][2]
Cancer (Glioblastoma)	Nude mice with U87MG xenografts	Not specified	Not specified	Daily for 2 weeks	Vehicle	Significantly decreased tumor growth.	[3]
Cancer (Breast)	BALB/c mice with 4T1 mammary carcinoma	10, 50, or 100 µg per mouse	Intravenous (i.v.)	Weekly for 3 weeks	Saline	Reduced primary tumor weight and volume, increased	[4]

lifespan,
reduced
lung
metastasi
s.

Cardiovascular (Myocardial Fibrosis)	Aged female mice with transverse aortic constriction	35 µg/kg body weight	Intraperitoneal (i.p.)	Daily	Not specified	Reduced myocardial fibrosis and preserved cardiac function. [5]
--------------------------------------	--	----------------------	------------------------	-------	---------------	---

Experimental Protocols

Preparation of G-1 Solution

G-1 is typically prepared in a stock solution and then diluted to the final concentration in a suitable vehicle.

- Stock Solution: Prepare a stock solution of G-1 in ethanol or DMSO.[1]
- Working Solution:
 - For subcutaneous and intraperitoneal injections, the stock solution can be diluted in vehicles such as saline, corn oil, or cyclodextrin in saline.[1][6]
 - It is crucial to ensure the final concentration of solvents like DMSO is low (typically <10%) to avoid irritation, especially for intraperitoneal injections.[6]
 - Ensure the compound is fully dissolved. Gentle warming and vortexing may be necessary. [6]
 - All solutions for parenteral administration should be sterile and isotonic.[7]

Administration Routes

The choice of administration route depends on the desired absorption rate and duration of action. The general order of absorption rate is: Intravenous (IV) > Intraperitoneal (IP) > Intramuscular (IM) > Subcutaneous (SC) > Oral (PO).[7]

This method is suitable for sustained release and is common in long-term studies.[6]

- Materials: G-1 solution, sterile 1 mL syringe with a 25-27 gauge needle, 70% ethanol.[6]
- Procedure:
 - Gently restrain the mouse by scruffing the skin on its neck and back to form a "tent".[6]
 - Wipe the injection site (typically the dorsal, interscapular region) with 70% ethanol.[6]
 - Insert the needle, with the bevel facing up, into the base of the skin tent at a shallow angle, parallel to the spine.[6]
 - Gently pull back on the plunger to ensure the needle is not in a blood vessel.[6]
 - Slowly inject the G-1 solution (typically 100-200 μ L).[6]
 - Withdraw the needle and apply gentle pressure to the injection site.[6]
 - Monitor the mouse for any signs of distress or local reaction.[6]

This route allows for rapid absorption of the compound into the systemic circulation.[6]

- Materials: G-1 solution, sterile 1 mL syringe with a 25-27 gauge needle, 70% ethanol.[6]
- Procedure:
 - Restrain the mouse by scruffing its neck, allowing access to the hindquarters.[6]
 - Position the mouse with its head tilted slightly downward.[6]
 - Wipe the lower right or left quadrant of the abdomen with 70% ethanol.[6]
 - Insert the needle, bevel up, at a 30-45 degree angle into the peritoneal cavity. Avoid the midline to prevent injury to the bladder or cecum.[6]

- Gently aspirate to ensure the needle has not entered the intestines or bladder.[6]
- Inject the G-1 solution (typically 100-200 μL).[6]
- Withdraw the needle and return the mouse to its cage.[6]

This method is used for precise oral dosing.[8]

- Materials: G-1 formulation, sterile gavage needle (18-20 gauge with a bulb tip is recommended), sterile syringe.[6][7]
- Procedure:
 - Gently restrain the mouse.
 - Measure the distance from the tip of the mouse's nose to the last rib to determine the correct insertion depth for the gavage needle.[6]
 - Gently insert the gavage needle into the mouth, passing it over the tongue and down the esophagus. The needle should pass with minimal resistance.[6]
 - Slowly administer the G-1 formulation (typically 100-200 μL).[6]
 - Gently remove the gavage needle.
 - Monitor the mouse for any signs of respiratory distress.[6]

Mandatory Visualizations

Signaling Pathways

Activation of GPER by G-1 can trigger multiple downstream signaling cascades.[9] One of the primary pathways involves the transactivation of the Epidermal Growth Factor Receptor (EGFR), leading to the activation of the MAPK and PI3K/Akt pathways.[9][10]

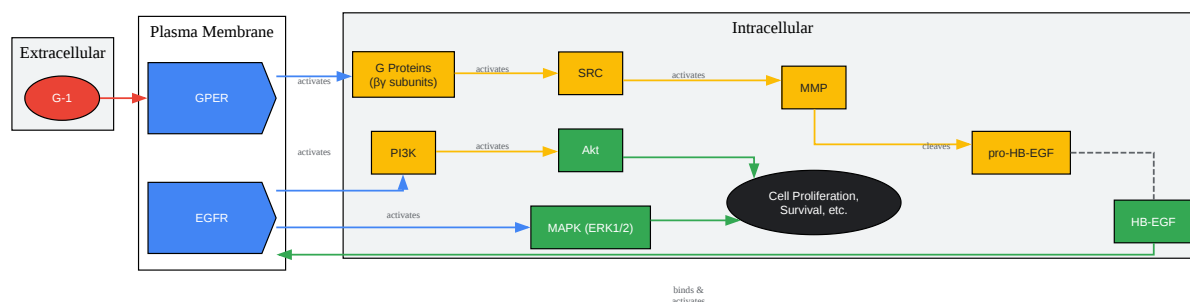

[Click to download full resolution via product page](#)

Caption: GPER signaling pathway initiated by G-1.

Experimental Workflow

The following diagram illustrates a general experimental workflow for evaluating the efficacy of G-1 in a tumor xenograft mouse model.

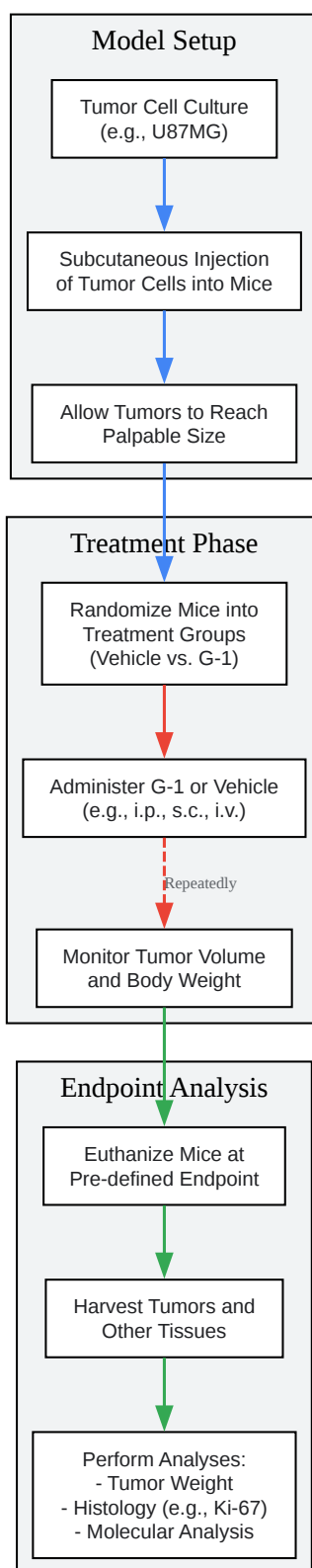

[Click to download full resolution via product page](#)

Caption: Workflow for G-1 efficacy testing in a xenograft model.

Need Custom Synthesis?

BenchChem offers custom synthesis for rare earth carbides and specific isotopic labeling.

Email: info@benchchem.com or [Request Quote Online](#).

References

- 1. Preclinical efficacy of the first-in-class GPER-selective agonist G-1 in mouse models of obesity and diabetes - PMC [[pmc.ncbi.nlm.nih.gov](https://pubmed.ncbi.nlm.nih.gov/)]
- 2. Preclinical efficacy of the GPER-selective agonist G-1 in mouse models of obesity and diabetes - PubMed [pubmed.ncbi.nlm.nih.gov]
- 3. [researchgate.net](https://www.researchgate.net/) [[researchgate.net](https://www.researchgate.net/)]
- 4. GK-1 peptide reduces tumor growth, decreases metastatic burden, and increases survival in a murine breast cancer model - PubMed [pubmed.ncbi.nlm.nih.gov]
- 5. G Protein–Coupled Estrogen Receptor 30 Reduces Transverse Aortic Constriction–Induced Myocardial Fibrosis in Aged Female Mice by Inhibiting the ERK1/2 -MMP-9 Signaling Pathway - PMC [[pmc.ncbi.nlm.nih.gov](https://pubmed.ncbi.nlm.nih.gov/)]
- 6. [benchchem.com](https://www.benchchem.com/) [[benchchem.com](https://www.benchchem.com/)]
- 7. cea.unizar.es [cea.unizar.es]
- 8. Manual Restraint and Common Compound Administration Routes in Mice and Rats - PMC [[pmc.ncbi.nlm.nih.gov](https://pubmed.ncbi.nlm.nih.gov/)]
- 9. The Role of G Protein-Coupled Estrogen Receptor (GPER) in Vascular Pathology and Physiology - PMC [[pmc.ncbi.nlm.nih.gov](https://pubmed.ncbi.nlm.nih.gov/)]
- 10. academic.oup.com [academic.oup.com]
- To cite this document: BenchChem. [G-1 Dosage and Administration in Mouse Models: Application Notes and Protocols]. BenchChem, [2026]. [Online PDF]. Available at: [<https://www.benchchem.com/product/b10768565/docs#g-1-dosage-and-administration-in-mouse-models-application-notes-and-protocols>]

Disclaimer & Data Validity:

The information provided in this document is for Research Use Only (RUO) and is strictly not intended for diagnostic or therapeutic procedures. While BenchChem strives to provide

accurate protocols, we make no warranties, express or implied, regarding the fitness of this product for every specific experimental setup.

Technical Support: The protocols provided are for reference purposes. Unsure if this reagent suits your experiment?

Need Industrial/Bulk Grade? [Request Custom Synthesis Quote](#)

BenchChem

Our mission is to be the trusted global source of essential and advanced chemicals, empowering scientists and researchers to drive progress in science and industry.

Contact

Address: 3281 E Guasti Rd
Ontario, CA 91761, United States
Phone: (601) 213-4426
Email: info@benchchem.com

[Contact our Ph.D. Support Team for a compatibility check](#)