

For Researchers, Scientists, and RF System Developers

Author: BenchChem Technical Support Team. **Date:** April 2026

Compound of Interest

Compound Name: AM3102
Cat. No.: B10768044

[Get Quote](#)

This technical guide provides a comprehensive overview of the **AM3102**, a digitally tunable bandpass filter, tailored for academic and research applications in radio frequency (RF) engineering. The document details the device's technical specifications, offers experimental protocols for characterization, and illustrates its application in a research context, such as in the front-end of a software-defined radio (SDR) receiver.

The **AM3102** is a miniature integrated circuit that features digitally tunable bandpass filters covering a frequency range from 330 MHz to 1.2 GHz.[1][2] Its key feature is the independent 4-bit digital control of both the low-pass and high-pass corners, which allows for dynamic adjustment of the center frequency and bandwidth.[1][2] This flexibility makes it a valuable component for research in cognitive radio, dynamic spectrum access, and interference mitigation. The filter is packaged in a 4x6mm QFN and is designed to operate over a temperature range of -40°C to +85°C.[1]

Core Technical Specifications

The quantitative specifications of the **AM3102** are summarized in the table below, providing a clear basis for comparison and integration into research projects.

Parameter	Value	Notes
Frequency Range	330 MHz to 1.2 GHz	Can be extended to 450 MHz to 1.5 GHz depending on the application circuit.[2]
Insertion Loss	2.5 dB (Typical)	This is the signal power loss resulting from the insertion of the filter.[1]
Typical Rejection	40 dB	The typical attenuation of signals outside the passband. [1]
Input IP3	+40 dBm	A measure of the filter's linearity.[2]
Control Interface	4-bit digital control for low-pass corner	Independent control allows for adjustable center frequency and bandwidth.[1][2]
	4-bit digital control for high-pass corner	
Supply Voltage	+3.3V to +5.0V	
Logic Compatibility	3V or 5V	
Package	4x6mm QFN	A small form-factor suitable for compact RF front-ends.[1]
Operating Temperature	-40°C to +85°C	

Digital Control Logic

The **AM3102**'s passband is defined by the settings of its independent low-pass and high-pass filter corners. Each corner is controlled by a 4-bit digital word, providing 16 selectable states for each. The combination of these settings determines the center frequency and bandwidth of the filter.

Below is a diagram illustrating the logical relationship between the digital control words and the resulting filter response.

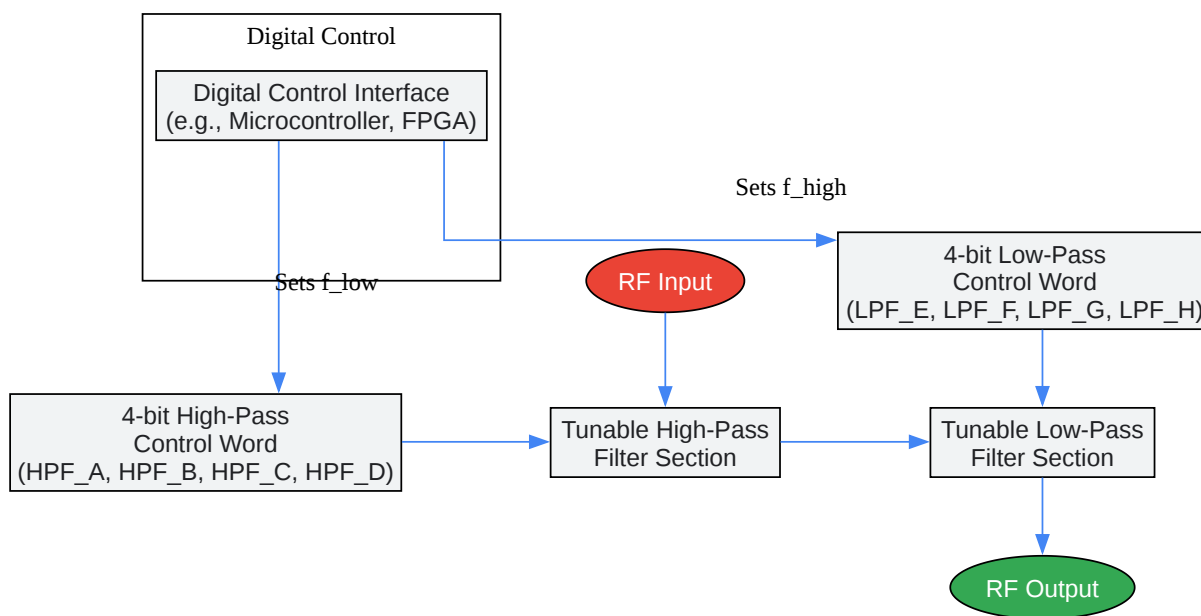

[Click to download full resolution via product page](#)

AM3102 Digital Control Logic

Experimental Protocols for Academic Research

Detailed methodologies for characterizing and utilizing the **AM3102** in a research setting are provided below. These protocols are designed to be adaptable for various research objectives in RF engineering.

Experiment 1: Characterization of the AM3102's Tuning Range and Performance

Objective: To systematically measure the filter's key performance indicators, including insertion loss, bandwidth, and out-of-band rejection, across its entire tuning range.

Materials:

- **AM3102** Evaluation Board
- Vector Network Analyzer (VNA)
- DC Power Supply (for the evaluation board)
- Digital Control Interface (e.g., Arduino, FPGA development board)
- SMA Cables and Adapters

Methodology:

- Setup:
 - Connect the **AM3102** evaluation board to the VNA. Port 1 of the VNA should be connected to the RF input of the board, and Port 2 to the RF output.
 - Power the evaluation board with the recommended DC voltage.
 - Connect the digital control interface to the control pins of the **AM3102** on the evaluation board.
- Calibration:
 - Perform a full two-port calibration on the VNA over the frequency range of interest (e.g., 100 MHz to 2 GHz) to eliminate the effects of cables and connectors.
- Measurement Procedure:
 - Program the digital control interface to systematically step through all possible combinations of the 4-bit high-pass and 4-bit low-pass control words (256 states in total).
 - For each state:

- Measure the S-parameters (S11 and S21) using the VNA.
 - From the S21 measurement, determine the center frequency, 3 dB bandwidth, and insertion loss at the center frequency.
 - From the S11 measurement, determine the return loss within the passband.
 - Analyze the out-of-band rejection at specific frequency offsets from the passband (e.g., ± 50 MHz, ± 100 MHz).
- Data Presentation:
 - Compile the measured data into a comprehensive table, with each row representing a unique digital control state and columns for the corresponding center frequency, bandwidth, insertion loss, and return loss.
 - Plot the filter's frequency response (S21) for a representative subset of tuning states to visualize the tunable passband.

The following diagram illustrates the experimental workflow for characterizing the **AM3102**.

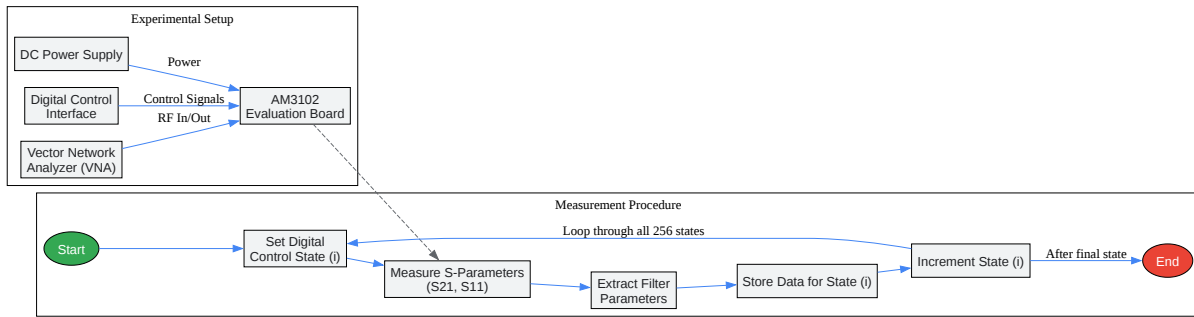

[Click to download full resolution via product page](#)

AM3102 Characterization Workflow

Experiment 2: Integration of AM3102 into an SDR Front-End for Interference Mitigation Research

Objective: To demonstrate the use of the **AM3102** as a pre-selector filter in an SDR receiver to dynamically reject strong out-of-band interferers.

Materials:

- **AM3102** Evaluation Board
- Software-Defined Radio (SDR) with a wideband front-end
- Two RF Signal Generators

- A wideband antenna or a direct connection for controlled experiments
- Digital Control Interface (e.g., connected to the SDR's host computer)
- Spectrum Analyzer (for monitoring)
- Coaxial cables, splitters, and attenuators

Methodology:

- Setup:
 - Configure one signal generator to produce a desired weak signal within the **AM3102**'s tuning range (e.g., at -80 dBm).
 - Configure the second signal generator to produce a strong interfering signal outside the initial passband of the desired signal (e.g., at -20 dBm).
 - Combine the outputs of the two signal generators and feed the combined signal to the input of the **AM3102** evaluation board.
 - Connect the output of the **AM3102** to the input of the SDR.
 - Connect the digital control interface for the **AM3102** to a host computer that also controls the SDR.
- Procedure:
 - Baseline Measurement: Initially, bypass the **AM3102** and feed the combined signal directly into the SDR. Observe the SDR's received spectrum and note the presence of the strong interferer and the potentially desensitized desired signal.
 - Static Filtering: Insert the **AM3102** and set its passband to include the desired signal while rejecting the interferer. Observe the SDR's received spectrum again to confirm the attenuation of the interferer and the improved reception of the desired signal.
 - Dynamic Tuning: Develop a simple algorithm on the host computer that:

- Scans the spectrum using the SDR to detect the presence of strong interferers.
 - Based on the detected interference, calculates the optimal digital control words for the **AM3102** to place the interferer in the filter's stopband while keeping the desired signal in the passband.
 - Dynamically reconfigures the **AM3102**'s passband in response to changes in the interferer's frequency.
- Data Presentation:
 - Present spectrum plots from the SDR showing the received signal with and without the **AM3102** in the signal path.
 - Create a table summarizing the signal-to-noise ratio (SNR) of the desired signal under different interference and filtering conditions.
 - Provide a flowchart of the dynamic tuning algorithm.

The following diagram illustrates the experimental setup for the SDR integration experiment.

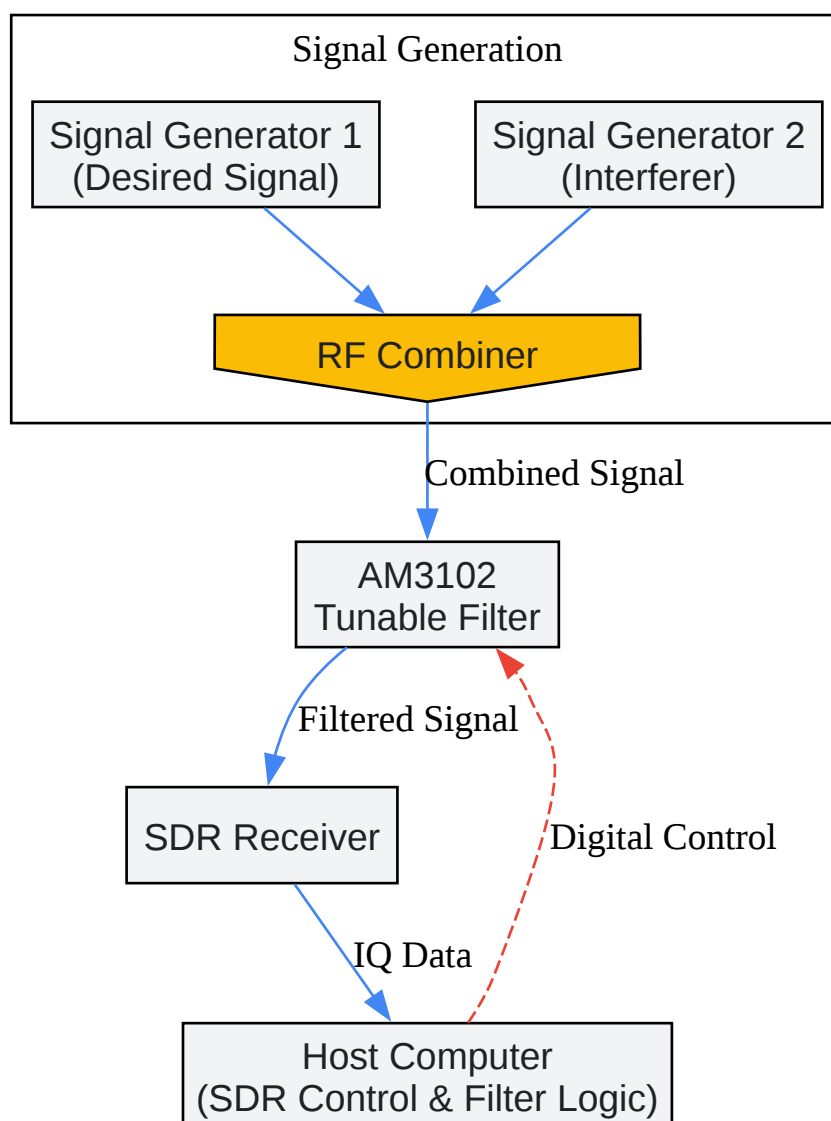

[Click to download full resolution via product page](#)

SDR Integration Experimental Setup

This guide provides a foundational understanding of the **AM3102** and its application in academic RF engineering research. The detailed specifications and experimental protocols offer a starting point for researchers to explore the capabilities of digitally tunable filters in advanced wireless communication systems.

Need Custom Synthesis?

BenchChem offers custom synthesis for rare earth carbides and specific isotopic labeling.

Email: info@benchchem.com or [Request Quote Online](#).

References

- [1. AM3102 Tunable MMIC Filter | Mercury Systems \[mrcy.com\]](#)
- [2. mrcy.com \[mrcy.com\]](#)
- To cite this document: BenchChem. [For Researchers, Scientists, and RF System Developers]. BenchChem, [2026]. [Online PDF]. Available at: [\[https://www.benchchem.com/product/b10768044/docs#for-researchers-scientists-and-rf-system-developers\]](https://www.benchchem.com/product/b10768044/docs#for-researchers-scientists-and-rf-system-developers)

Disclaimer & Data Validity:

The information provided in this document is for Research Use Only (RUO) and is strictly not intended for diagnostic or therapeutic procedures. While BenchChem strives to provide accurate protocols, we make no warranties, express or implied, regarding the fitness of this product for every specific experimental setup.

Technical Support: The protocols provided are for reference purposes. Unsure if this reagent suits your experiment?

Need Industrial/Bulk Grade? [Request Custom Synthesis Quote](#)

BenchChem

Our mission is to be the trusted global source of essential and advanced chemicals, empowering scientists and researchers to drive progress in science and industry.

Contact

Address: 3281 E Guasti Rd
Ontario, CA 91761, United States
Phone: (601) 213-4426
Email: info@benchchem.com

[Contact our Ph.D. Support Team for a compatibility check](#)

