

# Application Notes and Protocols for Testing AM3102 Efficacy in Cell Culture

**Author:** BenchChem Technical Support Team. **Date:** April 2026

## Compound of Interest

Compound Name: AM3102  
Cat. No.: B10768088

[Get Quote](#)

For Researchers, Scientists, and Drug Development Professionals

## Introduction

**AM3102** is a novel investigational compound with potential therapeutic applications in oncology. These application notes provide a comprehensive overview and detailed protocols for assessing the efficacy of **AM3102** in vitro using a panel of cell-based assays. The following protocols are designed to be adaptable to various cancer cell lines and research objectives. For the purpose of these notes, **AM3102** is hypothesized to be an inhibitor of the PI3K/Akt/mTOR signaling pathway, a critical cascade often dysregulated in cancer, leading to uncontrolled cell proliferation and survival.

## Hypothesized Mechanism of Action of AM3102

The phosphatidylinositol 3-kinase (PI3K)/Akt/mammalian target of rapamycin (mTOR) pathway is a key signaling cascade that regulates cell growth, proliferation, survival, and metabolism. In many cancers, this pathway is constitutively active, promoting tumorigenesis. **AM3102** is postulated to exert its anti-cancer effects by inhibiting one or more key kinases within this pathway, thereby blocking downstream signaling and inducing cancer cell death.

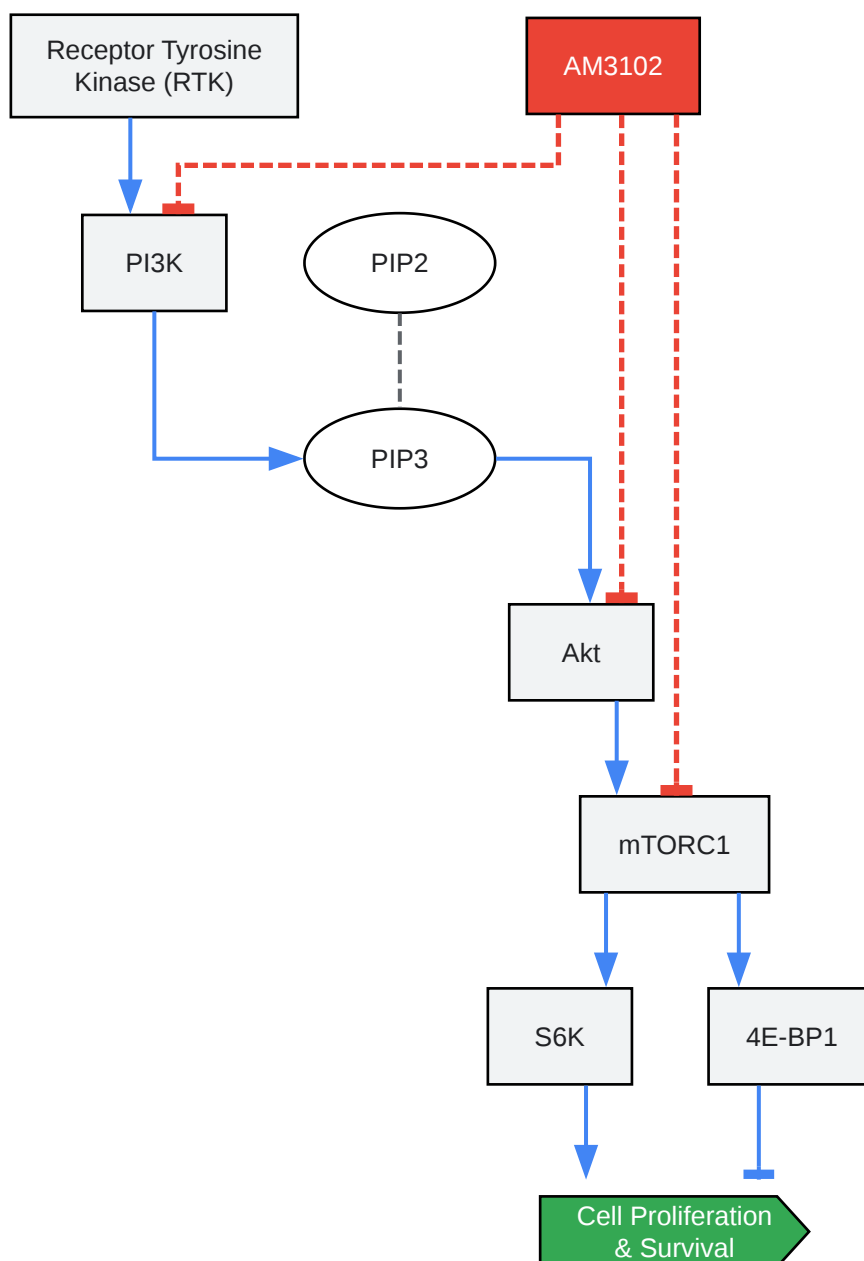
Diagram of the Hypothesized **AM3102** Signaling Pathway

[Click to download full resolution via product page](#)

Caption: Hypothesized inhibition of the PI3K/Akt/mTOR pathway by **AM3102**.

## Experimental Protocols

### Cell Viability Assay (MTT Assay)

This assay measures the metabolic activity of cells as an indicator of cell viability.

### Workflow Diagram: MTT Assay



[Click to download full resolution via product page](#)

Caption: Workflow for assessing cell viability using the MTT assay.

### Protocol:

- Seed cells in a 96-well plate at a density of 5,000-10,000 cells/well and incubate for 24 hours.
- Prepare serial dilutions of **AM3102** in cell culture medium.
- Remove the old medium from the wells and add 100  $\mu$ L of the **AM3102** dilutions. Include vehicle control wells.
- Incubate the plate for 48-72 hours.
- Add 10  $\mu$ L of MTT reagent (5 mg/mL in PBS) to each well and incubate for 2-4 hours at 37°C.
- Remove the medium and add 100  $\mu$ L of DMSO to each well to dissolve the formazan crystals.
- Measure the absorbance at 570 nm using a microplate reader.
- Calculate the percentage of cell viability relative to the vehicle control and determine the IC50 value.

### Data Presentation: Cell Viability (IC50 Values)

Cell Line	AM3102 IC50 ( $\mu\text{M}$ )
MCF-7 (Breast Cancer)	$1.5 \pm 0.2$
A549 (Lung Cancer)	$2.8 \pm 0.4$
U87-MG (Glioblastoma)	$0.9 \pm 0.1$
HCT116 (Colon Cancer)	$3.2 \pm 0.5$

## Cell Proliferation Assay (BrdU Incorporation)

This assay measures DNA synthesis as a marker of cell proliferation.

### Workflow Diagram: BrdU Assay



[Click to download full resolution via product page](#)

Caption: Workflow for the BrdU cell proliferation assay.

### Protocol:

- Follow steps 1-4 of the MTT assay protocol.
- Add BrdU labeling solution to each well and incubate for 2-4 hours.
- Remove the labeling medium, and fix and denature the cells according to the manufacturer's protocol.
- Add the anti-BrdU antibody and incubate.
- Wash the wells and add the substrate solution.
- Measure the chemiluminescence or colorimetric signal using a microplate reader.
- Express the data as a percentage of proliferation relative to the vehicle control.

## Data Presentation: Cell Proliferation

Cell Line	AM3102 (1 $\mu$ M) % Proliferation Inhibition
MCF-7	65 $\pm$ 5%
A549	58 $\pm$ 7%
U87-MG	72 $\pm$ 4%
HCT116	55 $\pm$ 6%

## Apoptosis Assay (Annexin V/PI Staining)

This assay differentiates between viable, early apoptotic, late apoptotic, and necrotic cells.

Workflow Diagram: Apoptosis Assay

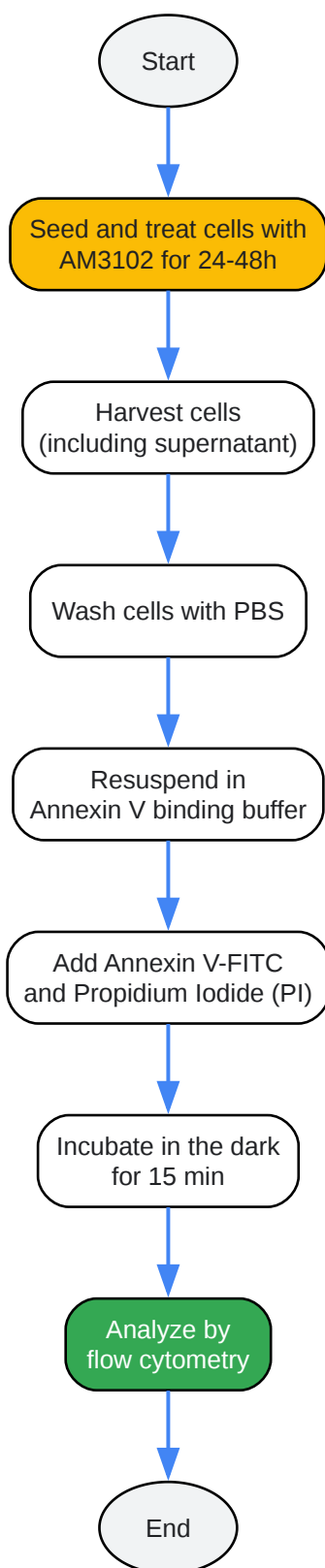

[Click to download full resolution via product page](#)

Caption: Workflow for Annexin V/PI apoptosis detection by flow cytometry.

Protocol:

- Seed cells in a 6-well plate and treat with **AM3102** for 24-48 hours.
- Harvest the cells, including the floating cells in the medium.
- Wash the cells with cold PBS.
- Resuspend the cells in Annexin V binding buffer.
- Add Annexin V-FITC and Propidium Iodide (PI) and incubate in the dark for 15 minutes at room temperature.
- Analyze the cells by flow cytometry within one hour.

Data Presentation: Apoptosis Induction

Cell Line (Treatment)	% Early Apoptotic Cells	% Late Apoptotic Cells
U87-MG (Vehicle)	3.1 ± 0.5%	1.5 ± 0.3%
U87-MG (AM3102, 1 µM)	25.4 ± 2.1%	15.8 ± 1.9%
U87-MG (AM3102, 5 µM)	42.7 ± 3.5%	28.3 ± 2.7%

## Western Blot Analysis of PI3K/Akt/mTOR Pathway

This technique is used to measure the levels of key proteins and their phosphorylation status to confirm target engagement.

Workflow Diagram: Western Blot

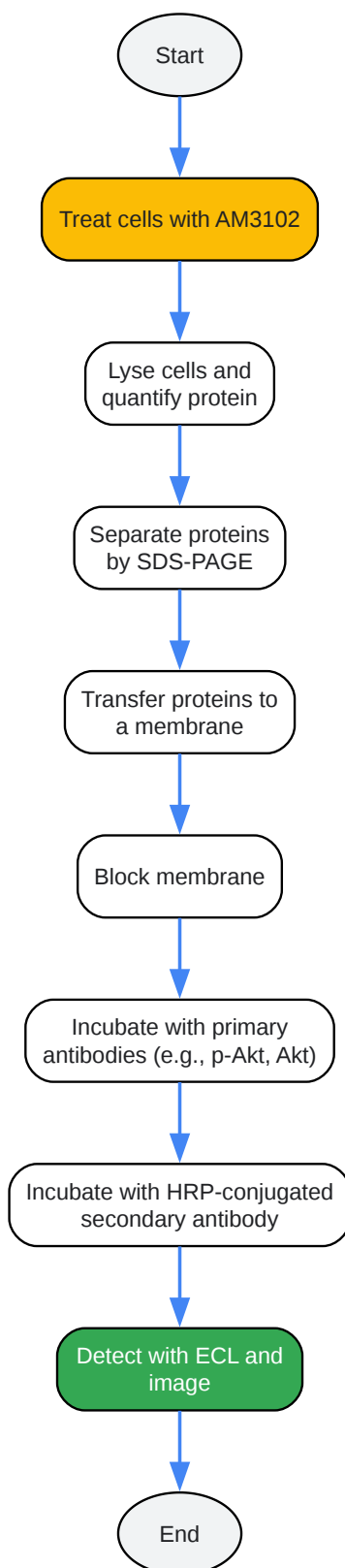

[Click to download full resolution via product page](#)

Caption: General workflow for Western blot analysis.

## Protocol:

- Treat cells with **AM3102** for the desired time (e.g., 2, 6, 24 hours).
- Lyse the cells in RIPA buffer containing protease and phosphatase inhibitors.
- Determine the protein concentration using a BCA assay.
- Separate equal amounts of protein on an SDS-PAGE gel.
- Transfer the proteins to a PVDF membrane.
- Block the membrane with 5% non-fat milk or BSA in TBST.
- Incubate the membrane with primary antibodies against p-Akt (Ser473), Akt, p-mTOR (Ser2448), mTOR, p-S6K (Thr389), S6K, p-4E-BP1 (Thr37/46), and a loading control (e.g.,  $\beta$ -actin or GAPDH) overnight at 4°C.
- Wash the membrane and incubate with the appropriate HRP-conjugated secondary antibody.
- Detect the protein bands using an enhanced chemiluminescence (ECL) substrate and an imaging system.
- Quantify the band intensities using image analysis software.

## Data Presentation: Pathway Inhibition

Target Protein	AM3102 (1 $\mu$ M) - Fold Change in Phosphorylation (Normalized to Total Protein)
p-Akt (Ser473)	0.2 $\pm$ 0.05
p-mTOR (Ser2448)	0.3 $\pm$ 0.07
p-S6K (Thr389)	0.15 $\pm$ 0.04
p-4E-BP1 (Thr37/46)	0.4 $\pm$ 0.06

## Conclusion

These application notes provide a framework for the initial in vitro characterization of **AM3102**. The described assays will help to elucidate its anti-cancer efficacy by assessing its impact on cell viability, proliferation, and apoptosis. Furthermore, Western blot analysis will be crucial in confirming its mechanism of action by demonstrating the inhibition of the PI3K/Akt/mTOR signaling pathway. The presented protocols and data tables serve as a guide for researchers to design, execute, and interpret experiments aimed at evaluating the therapeutic potential of **AM3102**.

- To cite this document: BenchChem. [Application Notes and Protocols for Testing AM3102 Efficacy in Cell Culture]. BenchChem, [2026]. [Online PDF]. Available at: [<https://www.benchchem.com/product/b10768088/docs#application-notes-and-protocols-for-testing-am3102-efficacy-in-cell-culture>]

---

### Disclaimer & Data Validity:

The information provided in this document is for Research Use Only (RUO) and is strictly not intended for diagnostic or therapeutic procedures. While BenchChem strives to provide accurate protocols, we make no warranties, express or implied, regarding the fitness of this product for every specific experimental setup.

**Technical Support:** The protocols provided are for reference purposes. Unsure if this reagent suits your experiment?

**Need Industrial/Bulk Grade?** [Request Custom Synthesis Quote](#)

## BenchChem

Our mission is to be the trusted global source of essential and advanced chemicals, empowering scientists and researchers to drive progress in science and industry.

### Contact

Address: 3281 E Guasti Rd

Ontario, CA 91761, United States

Phone: (601) 213-4426

Email: [info@benchchem.com](mailto:info@benchchem.com)

Contact our Ph.D. Support Team for a compatibility check