

# Technical Support Center: S-2 Methanandamide Experimental Troubleshooting

**Author:** BenchChem Technical Support Team. **Date:** April 2026

## Compound of Interest

Compound Name: S-2 Methanandamide

Cat. No.: B10767430

[Get Quote](#)

Status: Operational Role: Senior Application Scientist Subject: Troubleshooting Anomalous Results in Methanandamide (S-2/R-1) Assays

## Executive Summary: The "S-2" Trap

If you are experiencing unexpected results—specifically low potency, rapid signal loss, or lack of metabolic stability—with "**S-2 Methanandamide**," you are likely encountering one of three critical failure modes:

- **Stereochemical Mismatch:** You may be using the (S)-isomer (often labeled S-1 or S-2 depending on methylation site), which has significantly lower affinity for CB1 than the (R)-isomer.[\[1\]](#)[\[2\]](#)[\[3\]](#)
- **The "2-Methyl" Instability:** If your compound is methylated at the C-2 position of the arachidonyl chain (e.g., R-2 or **S-2 Methanandamide**) rather than the chiral carbon of the ethanolamine head group, it does not possess the resistance to Fatty Acid Amide Hydrolase (FAAH) that standard Methanandamide (AM-356) is famous for.[\[1\]](#)[\[2\]](#)[\[3\]](#)
- **Lipophilic Adsorption:** The compound is adhering to your plasticware, reducing the effective concentration to near zero.

## Module 1: The Potency Paradox (Stereochemistry & Structure)

Symptom: My

or

values are 10-20x higher (weaker) than literature values.

The term "Methanandamide" is often used loosely, but the stereochemistry is non-negotiable for CB1 activation.

### The Critical Distinction

Standard "stable" Methanandamide is (R)-(+)-Methanandamide (often coded as R-1).[1][2][3] It is methylated at the 1' position of the ethanolamine head group.

- (R)-Methanandamide: High affinity (nM), FAAH resistant.[2][3]
- (S)-Methanandamide: Low affinity (nM), often used as a negative control or less active isomer.[2][3]
- (R/S)-2-Methanandamide: Methylated on the arachidonyl tail.[2][3][4] NOT metabolically stable.[1][2][3]

### Comparative Data Table: Know Your Molecule

Compound Variant	Methyl Position	CB1 Affinity ( )	FAAH Stability	Primary Utility
(R)-1-Methanandamide	1'-hydroxy-2'-propyl (Head)	~ 20 nM (High)	High (Resistant)	The standard stable agonist.[1][2][3]
(S)-1-Methanandamide	1'-hydroxy-2'-propyl (Head)	~ 175 nM (Low)	High	Stereoselectivity control.[2][3]
(R)-2-Methanandamide	C-2 of Arachidonyl (Tail)	Variable	Low (Susceptible)	Structure-activity studies.[1][2][3]
Anandamide (AEA)	None	~ 78 nM	Very Low (Hydrolyzed)	Endogenous ligand.

“

*Technical Insight: If you are using an "S-2" analog expecting it to behave like the famous "stable Methanandamide" (AM-356), you will see rapid degradation and poor binding.[1][2][3] Verify your CAS number immediately.*

- (R)-1-Methanandamide CAS: 157182-49-5
- (S)-1-Methanandamide CAS: 157182-50-8[2][3]

## Module 2: The "Disappearing Compound" (Solubility & Handling)

Symptom: Flat concentration-response curves or high variability between technical replicates.[1][2][3]

Methanandamide is a highly lipophilic lipid.[2][3] It hates water and loves plastic. If you dilute it into aqueous buffer in a polystyrene trough before adding it to your cells, you may lose up to

90% of the compound to the plastic walls before the experiment begins.

## The "Glass-First" Protocol

Goal: Minimize adsorption losses during dilution.[\[1\]](#)[\[2\]](#)[\[3\]](#)

- Stock Storage: Store stocks in 100% Ethanol or DMSO at -20°C or -80°C under nitrogen (to prevent oxidation).
- Intermediate Dilution: NEVER perform serial dilutions in standard plastic 96-well plates.
  - Correct: Use glass tubes or silanized polypropylene tubes.[\[1\]](#)[\[2\]](#)[\[3\]](#)
- The Carrier Protein: Aqueous buffers must contain a carrier to keep the lipid in solution.
  - Recommendation: Add 0.1% - 0.5% Fatty Acid-Free BSA (Bovine Serum Albumin) to your assay buffer.[\[1\]](#)[\[2\]](#)[\[3\]](#)
  - Warning: Too much BSA (>1%) acts as a "lipid sink," binding the drug so tightly it cannot interact with the receptor.

## Visualizing the Failure Mode

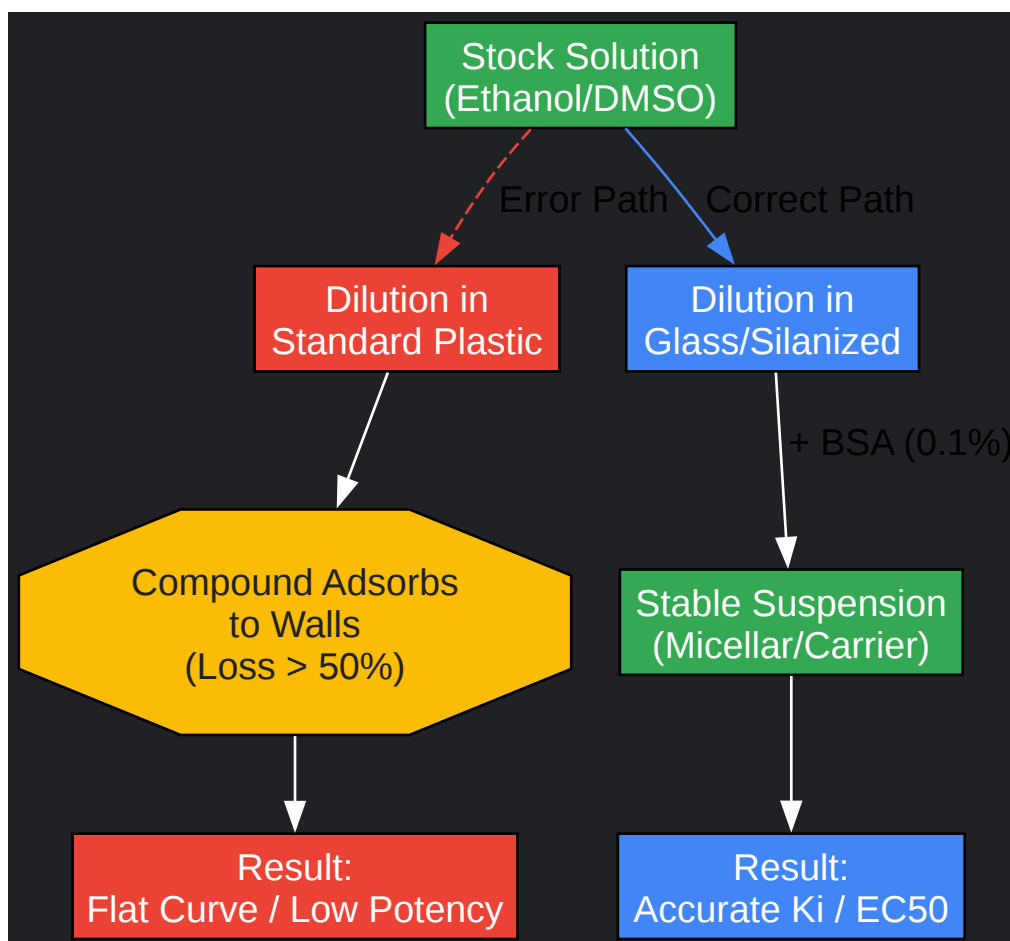

[Click to download full resolution via product page](#)

Figure 1: The "Stickiness" Failure Mode. Using standard plastic for intermediate dilutions leads to massive compound loss due to hydrophobic adsorption.

## Module 3: Biological Variance (Metabolism & Oxidation)[1][5][6][7][8][9]

Symptom: Signal decays over time despite using a "stable" analog.

Even if you use the FAAH-resistant (R)-isomer, the compound is not immortal.[1][2][3]

- Oxidative Degradation: The arachidonyl tail contains four double bonds (tetraene).[1][2] It is highly susceptible to oxidative degradation (lipid peroxidation) if exposed to air and light.
  - Fix: Use buffers degassed with Nitrogen or Argon.[2][3] Keep experiments in low light.

- Alternative Metabolism: While resistant to FAAH, Methanandamide can still be a substrate for COX-2 (Cyclooxygenase-2) and LOX (Lipoxygenase), generating prostamide-like byproducts that may have off-target effects.[1][2][3]
  - Troubleshooting: If you see complex signaling, pre-treat with Indomethacin (COX inhibitor) to rule out secondary metabolite effects.[2][3]

## Signaling & Degradation Pathway[1][2][3]

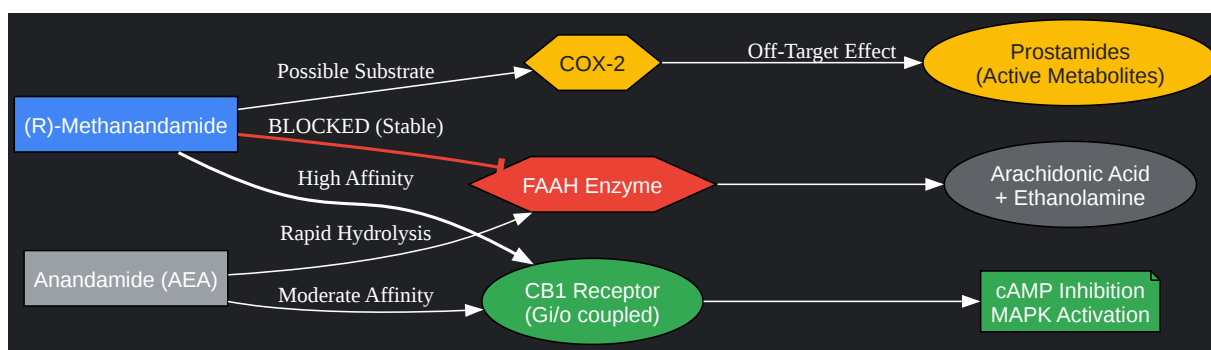

[Click to download full resolution via product page](#)

Figure 2: Metabolic Stability Comparison.[1][2][3] (R)-Methanandamide blocks FAAH hydrolysis but remains susceptible to COX-2 oxidation.[2][3]

## Frequently Asked Questions (FAQ)

Q: Can I dissolve Methanandamide directly in PBS? A: No. It will precipitate immediately.[1][2] Dissolve in 100% Ethanol or DMSO (up to 30-50 mg/ml), then dilute dropwise into a stirring buffer containing at least 0.1% BSA.

Q: Why is my "S-2" Methanandamide not working in my FAAH inhibition assay? A: If you are using (S)-Methanandamide, it is a weak agonist.[1][2][3] If you are using R-2 Methanandamide (methyl on the arachidonyl chain), it is not FAAH resistant.[1][2][3] You need (R)-1-Methanandamide (AM-356) for FAAH stability studies [1].[1][2][3]

Q: I see a "bell-shaped" dose-response curve. Why? A: This is classic cannabinoid behavior.[1]

[2] High concentrations can cause:

- Receptor desensitization/internalization (very rapid for CB1).[1][2]
- Non-specific membrane perturbation (lipid effects).[1][2]
- "Micelle" formation where the drug aggregates and becomes unavailable to the receptor.

## References

- Abadji, V., Lin, S., Taha, G., et al. (1994).[2][3][5][6][7] (R)-Methanandamide: A chiral novel anandamide possessing higher potency and metabolic stability.[1][2][3][5][7][8][9] *Journal of Medicinal Chemistry*, 37(12), 1889-1893.[2][3][7][8]
- Cayman Chemical. (n.d.).[1][2] R-1 Methanandamide Product Information.
- Pertwee, R.G. (1999).[2][3] Pharmacology of cannabinoid receptor ligands. *Current Medicinal Chemistry*, 6(8), 635-664.[2][3]
- Oddi, S., et al. (2011).[2][3] Pitfalls and solutions in assaying anandamide transport in cells. *Journal of Lipid Research*.

### *Need Custom Synthesis?*

*BenchChem offers custom synthesis for rare earth carbides and specific isotopic labeling.*

*Email: [info@benchchem.com](mailto:info@benchchem.com) or [Request Quote Online](#).*

## Sources

- 1. [caymanchem.com](https://www.caymanchem.com) [[caymanchem.com](https://www.caymanchem.com)]
- 2. [caymanchem.com](https://www.caymanchem.com) [[caymanchem.com](https://www.caymanchem.com)]
- 3. [caymanchem.com](https://www.caymanchem.com) [[caymanchem.com](https://www.caymanchem.com)]
- 4. Stereochemical selectivity of methanandamides for the CB1 and CB2 cannabinoid receptors and their metabolic stability - PubMed [[pubmed.ncbi.nlm.nih.gov](https://pubmed.ncbi.nlm.nih.gov)]

- [5. The Endogenous Cannabinoid Anandamide and Its Synthetic Analog R\(+\)-Methanandamide Are Intravenously Self-Administered by Squirrel Monkeys - PMC \[pmc.ncbi.nlm.nih.gov\]](#)
- [6. Factors influencing the regional haemodynamic responses to methanandamide and anandamide in conscious rats - PMC \[pmc.ncbi.nlm.nih.gov\]](#)
- [7. apexbt.com \[apexbt.com\]](#)
- [8. medchemexpress.com \[medchemexpress.com\]](#)
- [9. \(R\)-methanandamide: a chiral novel anandamide possessing higher potency and metabolic stability - PubMed \[pubmed.ncbi.nlm.nih.gov\]](#)
- To cite this document: BenchChem. [Technical Support Center: S-2 Methanandamide Experimental Troubleshooting]. BenchChem, [2026]. [Online PDF]. Available at: [<https://www.benchchem.com/product/b10767430/docs#technical-support-center-s-2-methanandamide-experimental-troubleshooting>]

---

#### Disclaimer & Data Validity:

The information provided in this document is for Research Use Only (RUO) and is strictly not intended for diagnostic or therapeutic procedures. While BenchChem strives to provide accurate protocols, we make no warranties, express or implied, regarding the fitness of this product for every specific experimental setup.

**Technical Support:** The protocols provided are for reference purposes. Unsure if this reagent suits your experiment?

**Need Industrial/Bulk Grade?** [Request Custom Synthesis Quote](#)

## BenchChem

Our mission is to be the trusted global source of essential and advanced chemicals, empowering scientists and researchers to drive progress in science and industry.

#### Contact

Address: 3281 E Guasti Rd  
Ontario, CA 91761, United States  
Phone: (601) 213-4426  
Email: [info@benchchem.com](mailto:info@benchchem.com)

Contact our Ph.D. Support Team for a compatibility check