

Technical Support Center: CAY10581 In Vitro Efficacy

Author: BenchChem Technical Support Team. **Date:** April 2026

Compound of Interest

Compound Name: CAY10581

Cat. No.: B10767794

[Get Quote](#)

This technical support center provides troubleshooting guides and frequently asked questions (FAQs) to assist researchers in optimizing the in vitro efficacy of **CAY10581**, a potent and reversible uncompetitive inhibitor of indoleamine 2,3-dioxygenase 1 (IDO1).

Frequently Asked Questions (FAQs)

Q1: What is the mechanism of action of **CAY10581**?

A1: **CAY10581** is a highly specific, reversible, and uncompetitive inhibitor of the IDO1 enzyme. [1] IDO1 is the rate-limiting enzyme in the kynurenine pathway, which is responsible for the degradation of the essential amino acid L-tryptophan. [2] By inhibiting IDO1, **CAY10581** blocks the conversion of tryptophan to N-formylkynurenine, leading to a decrease in the production of kynurenine and other downstream metabolites. This restores local tryptophan levels and mitigates the immunosuppressive effects of kynurenine, which can be beneficial in research areas such as oncology. [3][4]

Q2: What is the recommended starting concentration for in vitro experiments with **CAY10581**?

A2: A good starting point for in vitro experiments is to perform a dose-response curve spanning a wide range of concentrations, from nanomolar to micromolar, to determine the optimal

concentration for your specific cell line and experimental conditions. The reported half-maximal inhibitory concentration (IC₅₀) of **CAY10581** is 55 nM in cell-free enzymatic assays.[1] For cell-based assays, it is advisable to test concentrations around this value and extend the range to observe a full dose-response effect.

Q3: What solvents are recommended for dissolving **CAY10581**?

A3: **CAY10581** is soluble in organic solvents such as dimethyl sulfoxide (DMSO) and dimethylformamide (DMF). It is sparingly soluble in aqueous buffers. For cell-based assays, it is recommended to prepare a concentrated stock solution in 100% DMSO and then dilute it to the final working concentration in the cell culture medium. Ensure the final DMSO concentration in the culture medium is low (typically below 0.5%) to avoid solvent-induced cytotoxicity.

Q4: How stable is **CAY10581** in solution?

A4: Stock solutions of **CAY10581** in anhydrous DMSO can be stored at -20°C for extended periods. However, the stability of **CAY10581** in aqueous cell culture medium may be limited.[5] [6] It is recommended to prepare fresh dilutions in culture medium for each experiment and avoid repeated freeze-thaw cycles of the stock solution. If long-term experiments are planned, the stability of **CAY10581** in your specific cell culture medium at 37°C should be empirically determined.

Q5: Does **CAY10581** exhibit off-target effects?

A5: While **CAY10581** is described as a highly specific IDO1 inhibitor, all small molecule inhibitors have the potential for off-target effects, especially at higher concentrations.[7][8] It is crucial to include appropriate controls in your experiments to assess for any off-target effects. This can include using a structurally related but inactive compound as a negative control, or testing the effect of **CAY10581** in a cell line that does not express IDO1.

Troubleshooting Guides

Issue 1: Low or No Inhibition of IDO1 Activity

Possible Cause	Troubleshooting Step
Incorrect Compound Concentration	Verify the calculations for your serial dilutions. Perform a new dose-response experiment with a freshly prepared stock solution of CAY10581.
Compound Instability	Prepare fresh dilutions of CAY10581 in cell culture medium immediately before each experiment. Assess the stability of CAY10581 in your specific medium over the time course of your experiment.
Low IDO1 Expression in Cells	Ensure that your chosen cell line expresses sufficient levels of IDO1. For many cell lines, induction of IDO1 expression with interferon-gamma (IFN- γ) is necessary. ^[9] Confirm IDO1 expression by Western blot or qPCR.
Suboptimal Assay Conditions	Optimize the incubation time with CAY10581. Ensure that the substrate (L-tryptophan) concentration is not excessively high, as this can affect the apparent inhibitory activity.
Cell Permeability Issues	While CAY10581 is a small molecule, poor cell permeability could be a factor in certain cell types. Consider evaluating its intracellular concentration if this is a persistent issue.

Issue 2: High Variability in Experimental Replicates

Possible Cause	Troubleshooting Step
Inconsistent Cell Seeding	Ensure a homogenous cell suspension before seeding. Use a calibrated multichannel pipette for cell plating to ensure consistent cell numbers across wells.
Edge Effects in Multi-well Plates	Avoid using the outer wells of the plate, as these are more prone to evaporation and temperature fluctuations. Fill the outer wells with sterile PBS or medium.
Inconsistent Compound Addition	Ensure thorough mixing of CAY10581 in the culture medium before adding it to the cells.
Assay Readout Variability	If using a colorimetric or fluorometric assay, ensure that there is no interference from the compound itself or from components in the cell culture medium. Run appropriate controls, including a compound-only control.

Issue 3: Unexpected Cytotoxicity

Possible Cause	Troubleshooting Step
High DMSO Concentration	Ensure the final concentration of DMSO in the culture medium does not exceed 0.5%. ^[10] Perform a vehicle control with the same DMSO concentration to assess its effect on cell viability.
Compound-Induced Cytotoxicity	Perform a cell viability assay (e.g., MTT, CellTiter-Glo) in parallel with your IDO1 inhibition assay to determine the cytotoxic concentration of CAY10581 in your cell line. ^[11] The manufacturer states minimal impact on T-REx cell viability at 100 µM after 24 hours. ^[1]
Contamination	Regularly check your cell cultures for signs of microbial contamination. Use aseptic techniques throughout your experiments.

Quantitative Data Summary

Parameter	Value	Reference
IC50 (Enzymatic Assay)	55 nM	[1]
Solubility in DMSO	~3 mg/mL	-
Solubility in DMF	~10 mg/mL	-
Cell Viability (T-REx cells)	Minimal impact at 100 μ M after 24h	[1]
Cell Viability (MSCs)	Abrogated IFN- γ induced growth inhibition at 100 nM	[1]

Experimental Protocols

Protocol 1: In Vitro IDO1 Inhibition Assay in Human Cancer Cells (e.g., HeLa or SK-OV-3)

This protocol is adapted from established methods for assessing IDO1 inhibitor activity in cell culture.[9][12]

Materials:

- Human cancer cell line known to express IDO1 (e.g., HeLa, SK-OV-3)
- Complete cell culture medium (e.g., DMEM with 10% FBS)
- Recombinant human IFN- γ
- **CAY10581**
- DMSO
- 96-well cell culture plates
- L-Tryptophan
- Trichloroacetic acid (TCA)

- Ehrlich's Reagent (p-dimethylaminobenzaldehyde in acetic acid)
- Microplate reader

Procedure:

- Cell Seeding: Seed cells into a 96-well plate at a density that will result in a confluent monolayer after 24-48 hours.
- IDO1 Induction: After 24 hours, treat the cells with IFN- γ (e.g., 50-100 ng/mL) for 24 hours to induce IDO1 expression. Include a set of wells without IFN- γ as a negative control.
- Inhibitor Treatment: Prepare serial dilutions of **CAY10581** in complete culture medium. The final DMSO concentration should be consistent across all wells and ideally $\leq 0.1\%$. Remove the IFN- γ containing medium and add the **CAY10581** dilutions to the cells. Include a vehicle control (medium with DMSO only).
- Incubation: Incubate the plate for 24-48 hours at 37°C in a 5% CO₂ incubator.
- Kynurenine Measurement: a. After incubation, collect the cell culture supernatant. b. Add TCA to the supernatant to a final concentration of 10% to precipitate proteins. c. Incubate at 50°C for 30 minutes to hydrolyze N-formylkynurenine to kynurenine. d. Centrifuge the samples to pellet the precipitated proteins. e. Transfer the clear supernatant to a new 96-well plate. f. Add an equal volume of Ehrlich's reagent to each well and incubate at room temperature for 10-20 minutes. g. Measure the absorbance at 490-492 nm using a microplate reader.
- Data Analysis: a. Generate a standard curve using known concentrations of L-kynurenine. b. Calculate the concentration of kynurenine in each sample from the standard curve. c. Determine the percentage of IDO1 inhibition for each concentration of **CAY10581** relative to the vehicle-treated control. d. Plot the percentage of inhibition versus the log of the inhibitor concentration to determine the IC₅₀ value.

Protocol 2: Cell Viability Assay (MTT)

This protocol is a standard method to assess the cytotoxicity of a compound.

Materials:

- Cells of interest
- Complete cell culture medium
- **CAY10581**
- DMSO
- 96-well cell culture plates
- MTT (3-(4,5-dimethylthiazol-2-yl)-2,5-diphenyltetrazolium bromide) solution
- Solubilization solution (e.g., DMSO or a solution of SDS in HCl)
- Microplate reader

Procedure:

- Cell Seeding: Seed cells into a 96-well plate at an appropriate density.
- Compound Treatment: After 24 hours, treat the cells with serial dilutions of **CAY10581**. Include a vehicle control.
- Incubation: Incubate the plate for the desired time period (e.g., 24, 48, or 72 hours).
- MTT Addition: Add MTT solution to each well and incubate for 2-4 hours at 37°C.
- Solubilization: Remove the medium and add the solubilization solution to dissolve the formazan crystals.
- Absorbance Measurement: Measure the absorbance at a wavelength of 570 nm.
- Data Analysis: Calculate the percentage of cell viability relative to the vehicle-treated control.

Visualizations

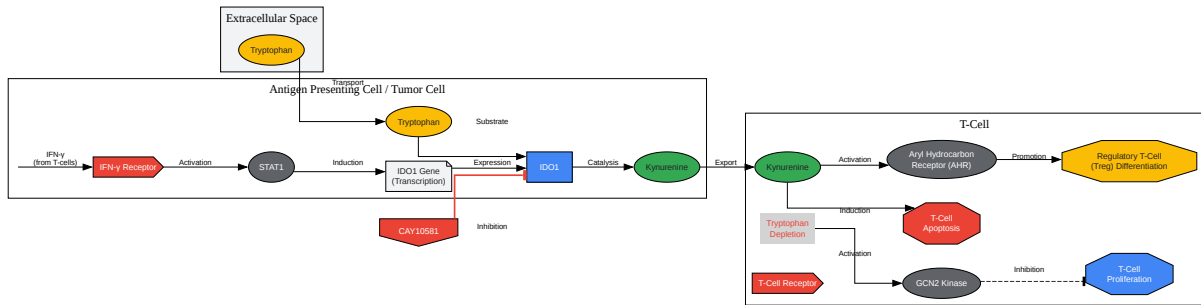

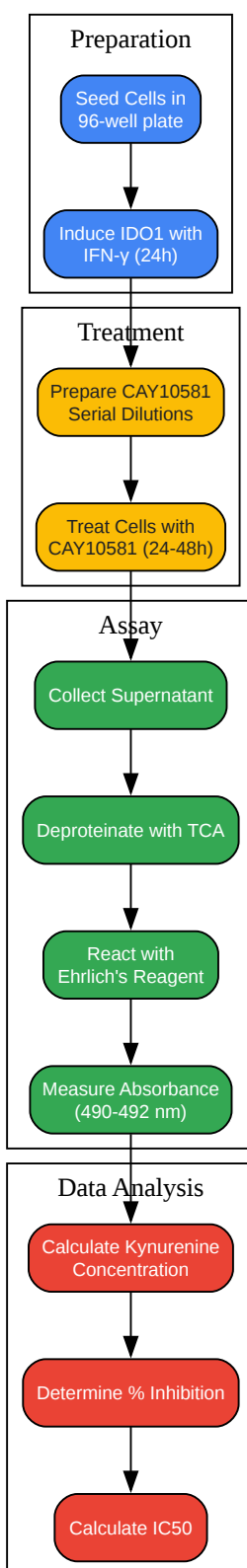

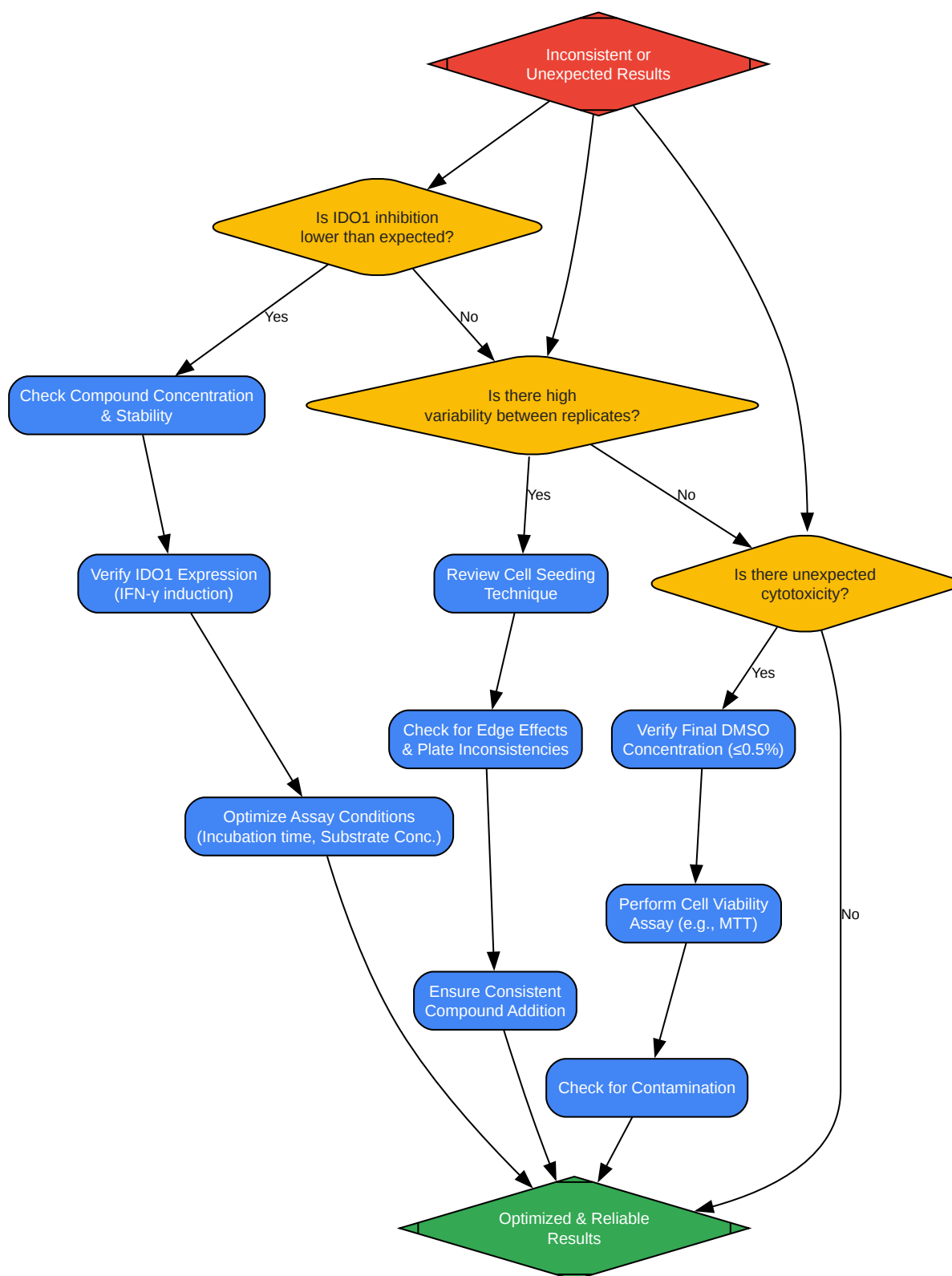

[Click to download full resolution via product page](#)

Need Custom Synthesis?

BenchChem offers custom synthesis for rare earth carbides and specific isotopic labeling.

Email: info@benchchem.com or [Request Quote Online](#).

References

- [1. medchemexpress.com \[medchemexpress.com\]](https://www.medchemexpress.com)
- [2. Indoleamine 2,3-dioxygenase 1 \(IDO1\): an up-to-date overview of an eclectic immunoregulatory enzyme - PMC \[pmc.ncbi.nlm.nih.gov\]](https://pubmed.ncbi.nlm.nih.gov/23111111/)
- [3. aacrjournals.org \[aacrjournals.org\]](https://www.aacrjournals.org)
- [4. Inflammatory reprogramming with IDO1 inhibitors: turning immunologically unresponsive 'cold' tumors 'hot' - PMC \[pmc.ncbi.nlm.nih.gov\]](https://pubmed.ncbi.nlm.nih.gov/23111111/)
- [5. mdpi.com \[mdpi.com\]](https://www.mdpi.com)
- [6. Effect of medium properties and additives on antibody stability and accumulation in suspended plant cell cultures - PubMed \[pubmed.ncbi.nlm.nih.gov\]](https://pubmed.ncbi.nlm.nih.gov/23111111/)
- [7. Limitations and Off-Target Effects of Tryptophan-Related IDO Inhibitors in Cancer Treatment - PMC \[pmc.ncbi.nlm.nih.gov\]](https://pubmed.ncbi.nlm.nih.gov/23111111/)
- [8. Predicting Off-Target Binding Profiles With Confidence Using Conformal Prediction - PubMed \[pubmed.ncbi.nlm.nih.gov\]](https://pubmed.ncbi.nlm.nih.gov/23111111/)
- [9. Cell based functional assays for IDO1 inhibitor screening and characterization - PMC \[pmc.ncbi.nlm.nih.gov\]](https://pubmed.ncbi.nlm.nih.gov/23111111/)
- [10. Optimization of cell viability assays to improve replicability and reproducibility of cancer drug sensitivity screens - PMC \[pmc.ncbi.nlm.nih.gov\]](https://pubmed.ncbi.nlm.nih.gov/23111111/)
- [11. benchchem.com \[benchchem.com\]](https://www.benchchem.com)
- [12. drugtargetreview.com \[drugtargetreview.com\]](https://www.drugtargetreview.com)
- To cite this document: BenchChem. [Technical Support Center: CAY10581 In Vitro Efficacy]. BenchChem, [2026]. [Online PDF]. Available at: [\[https://www.benchchem.com/product/b10767794/docs#technical-support-center-cay10581-in-vitro-efficacy\]](https://www.benchchem.com/product/b10767794/docs#technical-support-center-cay10581-in-vitro-efficacy)

Disclaimer & Data Validity:

The information provided in this document is for Research Use Only (RUO) and is strictly not intended for diagnostic or therapeutic procedures. While BenchChem strives to provide accurate protocols, we make no warranties, express or implied, regarding the fitness of this product for every specific experimental setup.

Technical Support: The protocols provided are for reference purposes. Unsure if this reagent suits your experiment?

Need Industrial/Bulk Grade? [Request Custom Synthesis Quote](#)

BenchChem

Our mission is to be the trusted global source of essential and advanced chemicals, empowering scientists and researchers to drive progress in science and industry.

Contact

Address: 3281 E Guasti Rd
Ontario, CA 91761, United States
Phone: (601) 213-4426
Email: info@benchchem.com

[Contact our Ph.D. Support Team for a compatibility check](#)