

5(S)-HpEPE: A Key Bioactive Lipid Mediator in Immunity

Author: BenchChem Technical Support Team. **Date:** April 2026

Compound of Interest

Compound Name: 5(S)-HpEPE

Cat. No.: B10767667

[Get Quote](#)

An In-depth Technical Guide for Researchers, Scientists, and Drug Development Professionals

Introduction

In the intricate landscape of the immune response, lipid mediators have emerged as critical signaling molecules that orchestrate the initiation, progression, and resolution of inflammation. Among these, the eicosanoids, derived from the metabolism of polyunsaturated fatty acids, play a pivotal role. 5(S)-hydroperoxyeicosapentaenoic acid (**5(S)-HpEPE**) is a key intermediate in the 5-lipoxygenase (5-LOX) pathway of eicosapentaenoic acid (EPA) metabolism. While often viewed as a transient precursor, **5(S)-HpEPE** and its downstream metabolites are potent bioactive lipids that actively modulate the functions of various immune cells, positioning the 5-LOX pathway as a significant target for therapeutic intervention in inflammatory diseases. This technical guide provides a comprehensive overview of the biosynthesis, metabolism, and immunological functions of **5(S)-HpEPE**, along with detailed methodologies for its study.

Part 1: Biosynthesis and Metabolism of 5(S)-HpEPE

The generation of **5(S)-HpEPE** is the initial and rate-limiting step in the 5-lipoxygenase pathway of EPA metabolism. This process is tightly regulated and occurs in specific immune

cells, primarily leukocytes such as neutrophils, eosinophils, monocytes/macrophages, and mast cells.[1]

1.1. The 5-Lipoxygenase Pathway

The biosynthesis of **5(S)-HpEPE** is initiated by the activation of cytosolic phospholipase A2 (cPLA2), which translocates to the nuclear envelope and hydrolyzes membrane phospholipids to release EPA.[2] The free EPA is then presented to the 5-lipoxygenase (5-LOX) enzyme by the 5-lipoxygenase-activating protein (FLAP), an integral nuclear membrane protein.[3][4] 5-LOX, in a calcium and ATP-dependent reaction, catalyzes the stereospecific insertion of molecular oxygen into EPA at the carbon-5 position, yielding **5(S)-HpEPE**. [1][5][6]

1.2. Metabolic Fates of **5(S)-HpEPE**

5(S)-HpEPE is an unstable intermediate with several metabolic fates:

- Reduction to 5(S)-HEPE: The most common fate of **5(S)-HpEPE** is its rapid reduction by cellular peroxidases, such as glutathione peroxidase, to the more stable 5(S)-hydroxyeicosapentaenoic acid (5(S)-HEPE).[5][7]
- Dehydration to Leukotriene A4 (LTA4) analog: 5-LOX can further catalyze the dehydration of **5(S)-HpEPE** to form the unstable epoxide, an analog of leukotriene A4 (LTA4).[8][9][10] This LTA4 analog is a precursor for the biosynthesis of other bioactive leukotrienes.
- Conversion to 5-oxo-EPE: 5(S)-HEPE can be further oxidized by 5-hydroxyeicosanoid dehydrogenase (5-HEDH) to form 5-oxo-eicosapentaenoic acid (5-oxo-EPE).[11][12] This conversion is particularly significant as 5-oxo-EPE is a more potent bioactive mediator than its precursor.[11] The synthesis of 5-oxo-EPE is enhanced under conditions of oxidative stress.[11][13]

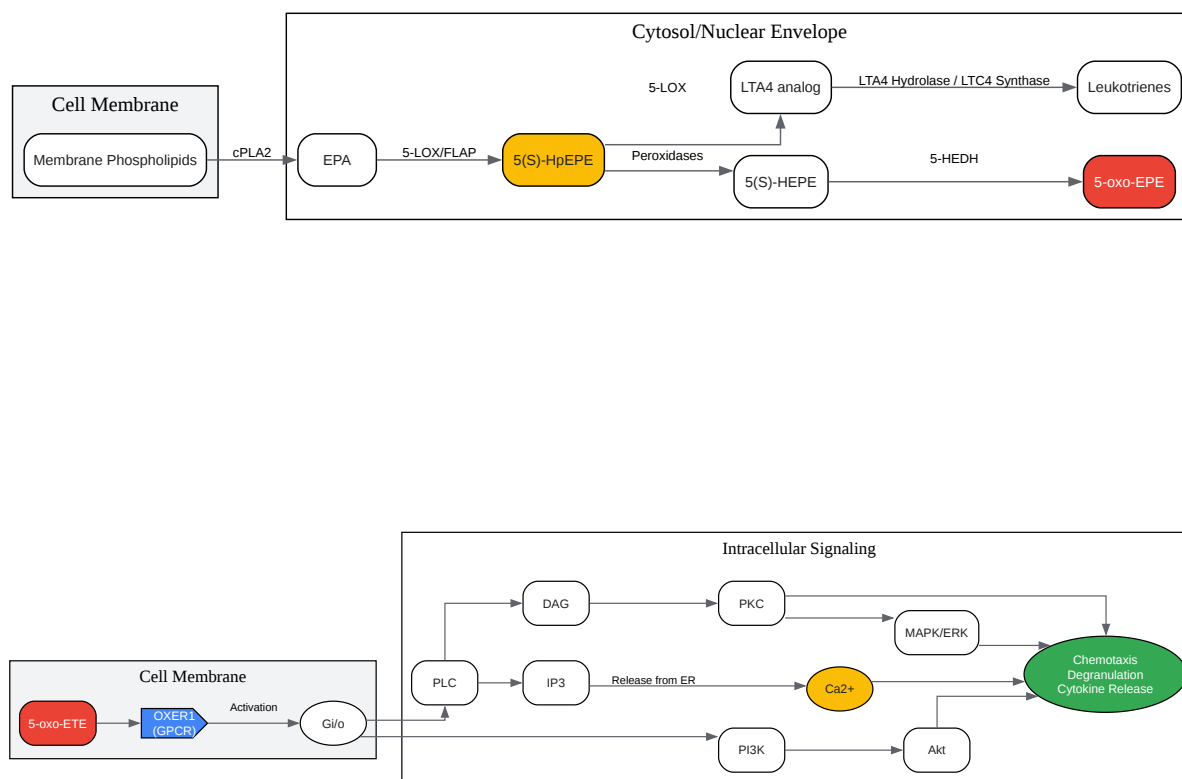

[Click to download full resolution via product page](#)

Caption: Simplified signaling pathway of 5-oxo-EETE via OXER1.

Part 3: Methodologies for Studying the 5(S)-HpEPE Axis

Investigating the role of **5(S)-HpEPE** and its metabolites requires specialized techniques for their extraction, quantification, and the assessment of their biological activities.

3.1. Quantification of **5(S)-HpEPE** and its Metabolites by LC-MS/MS

Liquid chromatography-tandem mass spectrometry (LC-MS/MS) is the gold standard for the sensitive and specific quantification of lipid mediators from biological samples.

3.1.1. Experimental Protocol: Lipid Mediator Extraction and Quantification

- Sample Collection and Preparation:
 - Collect biological samples (e.g., plasma, cell culture supernatant, tissue homogenate) and immediately add an antioxidant cocktail (e.g., butylated hydroxytoluene) to prevent auto-oxidation.
 - Spike the sample with a known amount of a deuterated internal standard (e.g., 5(S)-HETE-d8) for accurate quantification.
- Solid-Phase Extraction (SPE):
 - Condition a C18 SPE cartridge with methanol followed by water.
 - Acidify the sample to pH ~3.5 and load it onto the SPE cartridge.
 - Wash the cartridge with a low-organic solvent (e.g., 15% methanol) to remove polar impurities.
 - Elute the lipid mediators with a high-organic solvent (e.g., methanol or ethyl acetate).
- LC-MS/MS Analysis:
 - Evaporate the eluate to dryness under a stream of nitrogen and reconstitute in the mobile phase.
 - Inject the sample onto a reverse-phase C18 column.
 - Use a gradient elution with a mobile phase consisting of an aqueous solution with a weak acid (e.g., formic or acetic acid) and an organic solvent (e.g., acetonitrile/methanol).
 - Perform mass spectrometric analysis in negative ion mode using selected reaction monitoring (SRM) to detect the specific precursor-to-product ion transitions for each analyte and the internal standard.

3.2. In Vitro Bioactivity Assays

3.2.1. Neutrophil and Eosinophil Chemotaxis Assay

The Boyden chamber or Transwell® assay is a widely used method to assess the chemotactic activity of lipid mediators. [14][15] 3.2.1.1. Experimental Protocol: Chemotaxis Assay

- Cell Isolation: Isolate neutrophils or eosinophils from fresh whole blood using density gradient centrifugation.
- Assay Setup:
 - Place a Transwell® insert with a polycarbonate membrane (typically 3-5 µm pore size) into a 24-well plate.
 - Add the chemoattractant (e.g., 5-oxo-EPE) or control medium to the lower chamber.
 - Add the isolated immune cells to the upper chamber.
- Incubation: Incubate the plate at 37°C in a humidified incubator with 5% CO₂ for 1-2 hours.
- Quantification of Migrated Cells:
 - Remove the Transwell® insert.
 - Quantify the number of cells that have migrated to the lower chamber using a cell counter, a viability assay (e.g., CellTiter-Glo®), or by staining and microscopy.

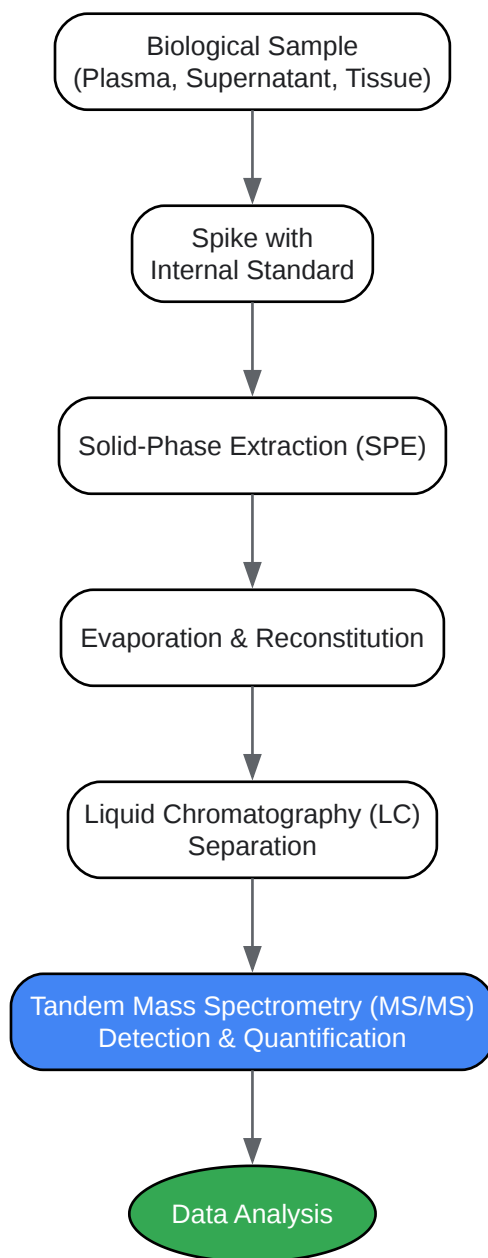

[Click to download full resolution via product page](#)

Caption: Workflow for lipid mediator analysis by LC-MS/MS.

Part 4: Therapeutic Implications and Future Directions

The significant pro-inflammatory roles of the 5-LOX pathway and its metabolites, particularly in the context of allergic diseases like asthma, have made it an attractive target for drug

development. [16][17][18][19] 4.1. Targeting the 5-LOX Pathway

Several therapeutic strategies have been developed to inhibit the 5-LOX pathway:

- 5-LOX inhibitors: These drugs directly inhibit the 5-lipoxygenase enzyme, preventing the production of all downstream metabolites. Zileuton is a clinically approved 5-LOX inhibitor for the treatment of asthma. [19][20]* FLAP inhibitors: These agents block the 5-lipoxygenase-activating protein, preventing the transfer of EPA to 5-LOX.
- OXER1 antagonists: The development of selective antagonists for the OXER1 receptor offers a more targeted approach to block the pro-inflammatory effects of 5-oxo-ETE and related compounds. [21][22]

The study of **5(S)-HpEPE** and its metabolites is a rapidly evolving field. Future research will likely focus on:

- Elucidating the precise roles of these mediators in a broader range of inflammatory and immune-mediated diseases.
- Identifying and characterizing novel receptors and signaling pathways.
- Developing more potent and specific inhibitors of the 5-LOX pathway with improved safety profiles.
- Investigating the potential for these lipid mediators to serve as biomarkers for disease activity and therapeutic response.

Conclusion

5(S)-HpEPE stands as a critical node in the network of bioactive lipid mediators that regulate immunity. While its existence is often transient, its metabolic products, particularly 5-oxo-EPE, are potent signaling molecules that drive key inflammatory processes, especially the recruitment and activation of eosinophils and neutrophils. A thorough understanding of the biosynthesis, metabolism, and immunological functions of the **5(S)-HpEPE** axis is essential for researchers and drug development professionals seeking to develop novel therapeutic strategies for a wide range of inflammatory disorders. The methodologies outlined in this guide provide a robust framework for the continued exploration of this important signaling pathway.

References

- Powell, W. S., & Rokach, J. (2015). Biosynthesis, biological effects, and receptors of hydroxyeicosatetraenoic acids (HETEs) and oxoeicosatetraenoic acids (oxo-ETEs) derived from arachidonic acid. *Biochimica et Biophysica Acta (BBA) - Molecular and Cell Biology of Lipids*, 1851(4), 340–355. [[Link](#)]
- Pinto, C., et al. (2021). Targeting Mammalian 5-Lipoxygenase by Dietary Phenolics as an Anti-Inflammatory Mechanism: A Systematic Review. *MDPI*. [[Link](#)]
- Wikipedia. (n.d.). 5-Hydroxyeicosatetraenoic acid. In Wikipedia. Retrieved from [[Link](#)]
- Powell, W. S., & Rokach, J. (2013). 5-Oxo-ETE and the OXE receptor. *Progress in Lipid Research*, 52(4), 651–665. [[Link](#)]
- Wikipedia. (n.d.). 5-Oxo-eicosatetraenoic acid. In Wikipedia. Retrieved from [[Link](#)]
- Patsnap Synapse. (2024). What are 5-LOX inhibitors and how do they work?. [[Link](#)]
- Grant, G. E., Rokach, J., & Powell, W. S. (2009). The eosinophil chemoattractant 5-oxo-ETE and the OXE receptor. *Journal of Leukocyte Biology*, 85(5), 757–766. [[Link](#)]
- Cipollone, F., et al. (2011). The 5-Lipoxygenase as a Common Pathway for Pathological Brain and Vascular Aging. *The 5-Lipoxygenase as a Common Pathway for Pathological Brain and Vascular Aging*. [[Link](#)]
- Patsnap Synapse. (2024). What are OXER1 antagonists and how do they work?. [[Link](#)]
- He, L., et al. (2024). Biological Roles of 5-Oxo-6,8,11,14-Eicosatetraenoic Acid and the OXE Receptor in Allergic Diseases: *Collegium Internationale Allergologicum Update 2024*. Karger Publishers. [[Link](#)]
- Rådmark, O., & Samuelsson, B. (2007). 5-Lipoxygenase: mechanisms of regulation. *Journal of Lipid Research*, 48(11), 2329–2346. [[Link](#)]
- Peters-Golden, M. (1997). Cell Biology of the 5-Lipoxygenase Pathway. *American Journal of Respiratory and Critical Care Medicine*, 155(1), 3–7. [[Link](#)]

- Gkika, E., et al. (2023). 5-Oxo-ETE/OXER1: A Link between Tumor Cells and Macrophages Leading to Regulation of Migration. MDPI. [[Link](#)]
- Reactome. (n.d.). 5S-HpETE is dehydrated to LTA4 by ALOX5. Reactome Pathway Database. [[Link](#)]
- Schneider, C., et al. (2007). Biosynthesis of hemiketal eicosanoids by cross-over of the 5-lipoxygenase and cyclooxygenase-2 pathways. Proceedings of the National Academy of Sciences, 104(52), 20847–20852. [[Link](#)]
- Perry, C. S., et al. (2020). Role of Human 15-Lipoxygenase-2 in the Biosynthesis of the Lipoxin Intermediate, 5S,15S-diHpETE. eScholarship.org. [[Link](#)]
- Liu, T., et al. (2022). Proposed mechanisms of metabolite 5-oxo-ETE and OXE-R on acute... ResearchGate. [[Link](#)]
- Silverman, E., et al. (1998). Pharmacogenetics of the 5-lipoxygenase Pathway in Asthma. PubMed. [[Link](#)]
- Jones, T. R., et al. (1996). The role of 5-lipoxygenase products in preclinical models of asthma. The Journal of Allergy and Clinical Immunology, 98(5), S116–S125. [[Link](#)]
- Murphy, R. C., & Gijón, M. A. (2007). Biosynthesis and metabolism of leukotrienes. Bioscience Reports, 27(1-3), 23–42. [[Link](#)]
- Lama, A., & Gualdieri, L. (2014). 5-Lipoxygenase Pathway, Dendritic Cells, and Adaptive Immunity. Mediators of Inflammation, 2014, 1–10. [[Link](#)]
- Dyczkowska, M., et al. (2016). A 5-LO product, 5-HETE, or its unstable precursor 5-HpETE is oxidized... ResearchGate. [[Link](#)]
- Gerstmeier, J., et al. (2022). Shifting the Biosynthesis of Leukotrienes Toward Specialized Pro-Resolving Mediators by the 5-Lipoxygenase-Activating Protein (FLAP) Antagonist BRP-201. Dove Medical Press. [[Link](#)]
- Drazen, J. (1995). Clinical studies with agents active on the 5-lipoxygenase pathway. Allergy, 50(22s), 22–26. [[Link](#)]

- Penrose, J. L., et al. (2013). 5-Lipoxygenase-activating protein rescues activity of 5-lipoxygenase mutations that delay nuclear membrane association and disrupt product formation. *The Journal of Biological Chemistry*, 288(47), 33964–33974. [[Link](#)]
- Wenzel, J., & Pignitter, M. (2021). The 5-lipoxygenase pathway. The 5-lipoxygenase protein (5LO) inserts... ResearchGate. [[Link](#)]
- Liu, M. C., et al. (1996). Acute and chronic effects of a 5-lipoxygenase inhibitor in asthma: a 6-month randomized multicenter trial. Zileuton Study Group. *The Journal of Allergy and Clinical Immunology*, 98(5 Pt 1), 859–871. [[Link](#)]
- Nagahora, N., et al. (2017). Nrf2 Activation by 5-lipoxygenase Metabolites in Human Umbilical Vascular Endothelial Cells. *Molecules*, 22(9), 1520. [[Link](#)]
- Charles River Laboratories. (n.d.). Neutrophil Chemotaxis Assay. [[Link](#)]
- Ferreira-Vera, C., et al. (2011). Standard operation protocol for analysis of lipid hydroperoxides in human serum using a fully automated method based on solid-phase extraction and liquid chromatography-mass spectrometry in selected reaction monitoring. *Journal of Chromatography A*, 1218(38), 6720–6726. [[Link](#)]
- BioMedha. (n.d.). Neutrophil Chemotaxis assay. [[Link](#)]
- Finethy, R., et al. (2019). IL-1 β , IL-18, and eicosanoids promote neutrophil recruitment to pore-induced intracellular traps following pyroptosis. *PLoS Pathogens*, 15(1), e1007536. [[Link](#)]
- Quinton, F., et al. (2024). LC-MS/MS analysis of 5 steroids in plasma in a clinical study of Congenital Adrenal Hyperplasia. *Protocols.io*. [[Link](#)]
- Oh, D. Y., et al. (2017). Eicosapentaenoic acid and 5-HEPE enhance macrophage-mediated Treg induction in mice. *Scientific Reports*, 7(1), 4645. [[Link](#)]
- Hong, S., et al. (2014). Mechanisms for anti-inflammatory effects of 1-[15(S)-hydroxyeicosapentaenoyl] lysophosphatidylcholine, administered intraperitoneally, in zymosan A-induced peritonitis. *The Journal of Biological Chemistry*, 289(15), 10560–10572. [[Link](#)]

- He, J., et al. (2017). An All-on-chip Method for Rapid Neutrophil Chemotaxis Analysis Directly from a Drop of Blood. *Journal of Visualized Experiments*, (124), 55711. [[Link](#)]
- Protocols Online. (n.d.). Protocols for Liquid Chromatography Coupled to MS for Proteome Analysis. [[Link](#)]
- Cellomatics Biosciences. (n.d.). Neutrophil Based Assays. [[Link](#)]
- RTSF. (2020). Protocol MSU_MSMC_013_ppGpp and pGpG using LC-MS-MS. [[Link](#)]
- Kunisawa, J., & Kiyono, H. (2018). Eicosanoids in inflammation in the blood and the vessel. *Seminars in Immunopathology*, 40(6), 557–568. [[Link](#)]
- Shajib, M. S., & Khan, W. I. (2015). 5-HT and the Immune System. *Serotonin*, 129–138. [[Link](#)]
- LGC. (n.d.). Guide to achieving reliable quantitative LC-MS measurements. [[Link](#)]
- Shajib, M. S., & Khan, W. I. (2015). The role of serotonin and its receptors in activation of immune responses and inflammation. *Acta Physiologica*, 213(3), 561–574. [[Link](#)]

Need Custom Synthesis?

BenchChem offers custom synthesis for rare earth carbides and specific isotopic labeling.

Email: info@benchchem.com or [Request Quote Online](#).

Sources

- 1. 5-Lipoxygenase: mechanisms of regulation - PMC [[pmc.ncbi.nlm.nih.gov](https://pubmed.ncbi.nlm.nih.gov/)]
- 2. 5-Lipoxygenase Pathway, Dendritic Cells, and Adaptive Immunity - PMC [[pmc.ncbi.nlm.nih.gov](https://pubmed.ncbi.nlm.nih.gov/)]
- 3. atsjournals.org [atsjournals.org]
- 4. dovepress.com [dovepress.com]
- 5. The 5-Lipoxygenase as a Common Pathway for Pathological Brain and Vascular Aging - PMC [[pmc.ncbi.nlm.nih.gov](https://pubmed.ncbi.nlm.nih.gov/)]

- [6. Pharmacogenetics of the 5-lipoxygenase pathway in asthma - PubMed \[pubmed.ncbi.nlm.nih.gov\]](#)
- [7. Eicosanoids in inflammation in the blood and the vessel - PMC \[pmc.ncbi.nlm.nih.gov\]](#)
- [8. Reactome | 5S-HpETE is dehydrated to LTA4 by ALOX5 \[reactome.org\]](#)
- [9. biosciencepharma.com \[biosciencepharma.com\]](#)
- [10. 5-Lipoxygenase-activating protein rescues activity of 5-lipoxygenase mutations that delay nuclear membrane association and disrupt product formation - PMC \[pmc.ncbi.nlm.nih.gov\]](#)
- [11. 5-Oxo-ETE and the OXE receptor - PMC \[pmc.ncbi.nlm.nih.gov\]](#)
- [12. The eosinophil chemoattractant 5-oxo-ETE and the OXE receptor - PMC \[pmc.ncbi.nlm.nih.gov\]](#)
- [13. karger.com \[karger.com\]](#)
- [14. criver.com \[criver.com\]](#)
- [15. biomedha.com \[biomedha.com\]](#)
- [16. What are 5-LOX inhibitors and how do they work? \[synapse.patsnap.com\]](#)
- [17. The role of 5-lipoxygenase products in preclinical models of asthma - PubMed \[pubmed.ncbi.nlm.nih.gov\]](#)
- [18. Clinical studies with agents active on the 5-lipoxygenase pathway - PubMed \[pubmed.ncbi.nlm.nih.gov\]](#)
- [19. Acute and chronic effects of a 5-lipoxygenase inhibitor in asthma: a 6-month randomized multicenter trial. Zileuton Study Group - PubMed \[pubmed.ncbi.nlm.nih.gov\]](#)
- [20. IL-1 \$\beta\$, IL-18, and eicosanoids promote neutrophil recruitment to pore-induced intracellular traps following pyroptosis - PMC \[pmc.ncbi.nlm.nih.gov\]](#)
- [21. Biosynthesis, biological effects, and receptors of hydroxyeicosatetraenoic acids \(HETEs\) and oxoeicosatetraenoic acids \(oxo-ETEs\) derived from arachidonic acid - PubMed \[pubmed.ncbi.nlm.nih.gov\]](#)
- [22. What are OXER1 antagonists and how do they work? \[synapse.patsnap.com\]](#)
- To cite this document: BenchChem. [5(S)-HpEPE: A Key Bioactive Lipid Mediator in Immunity]. BenchChem, [2026]. [Online PDF]. Available at: [\[https://www.benchchem.com/product/b10767667/docs#5-s-hpepe-a-key-bioactive-lipid-mediator-in-immunity\]](https://www.benchchem.com/product/b10767667/docs#5-s-hpepe-a-key-bioactive-lipid-mediator-in-immunity)

Disclaimer & Data Validity:

The information provided in this document is for Research Use Only (RUO) and is strictly not intended for diagnostic or therapeutic procedures. While BenchChem strives to provide accurate protocols, we make no warranties, express or implied, regarding the fitness of this product for every specific experimental setup.

Technical Support: The protocols provided are for reference purposes. Unsure if this reagent suits your experiment?

Need Industrial/Bulk Grade? [Request Custom Synthesis Quote](#)

BenchChem

Our mission is to be the trusted global source of essential and advanced chemicals, empowering scientists and researchers to drive progress in science and industry.

Contact

Address: 3281 E Guasti Rd
Ontario, CA 91761, United States
Phone: (601) 213-4426
Email: info@benchchem.com

[Contact our Ph.D. Support Team for a compatibility check](#)