

Micrococcin P1: A Technical Guide for Researchers

Author: BenchChem Technical Support Team. **Date:** May 2026

Compound of Interest

Compound Name: *Micrococcin P1*

Cat. No.: *B10765555*

[Get Quote](#)

An In-depth Review of the Thiopeptide Antibiotic for Drug Development Professionals

Introduction

Micrococcin P1 is a potent thiopeptide antibiotic with significant activity against a range of Gram-positive bacteria, including clinically important drug-resistant strains.[1][2] As a member of the Ribosomally Synthesized and Post-translationally Modified Peptides (RiPPs) class, its intricate chemical structure and unique mechanism of action make it a compelling candidate for further investigation and development in an era of mounting antibiotic resistance.[1][3] This technical guide provides a comprehensive overview of **Micrococcin P1**, including its antimicrobial profile, mechanism of action, biosynthetic pathway, and detailed experimental protocols to facilitate research and development efforts.

Antimicrobial Spectrum and Activity

Micrococcin P1 exhibits a potent, albeit narrow, spectrum of activity, primarily targeting Gram-positive bacteria. It has demonstrated significant efficacy against various strains of *Staphylococcus*, *Enterococcus*, *Streptococcus*, *Bacillus*, *Listeria*, and *Mycobacterium*. [1][4][5][6] Notably, it shows limited to no activity against Gram-negative bacteria. [4][7] The antimicrobial activity of **Micrococcin P1** is typically quantified by the Minimum Inhibitory

Concentration (MIC), which is the lowest concentration of the antibiotic that prevents visible growth of a microorganism.[6]

Table 1: Minimum Inhibitory Concentration (MIC) of Micrococccin P1 Against Various Bacterial Strains

Bacterial Species	Strain	MIC (µg/mL)	Reference(s)
Staphylococcus aureus	1974149	2	[8]
Staphylococcus aureus	KCTC 1927	0.05 - 0.8	[1][6]
Staphylococcus aureus	(MRSA)	0.5 - 1.0	[3][6]
Enterococcus faecalis	1674621	1	[8]
Streptococcus pyogenes	1744264	1	[8]
Kocuria rhizophila	KCTC 1915	0.05 - 0.8	[1][6]
Bacillus subtilis	KCTC 1021	0.05 - 0.8	[1][6]
Listeria monocytogenes	(95 strains)	Inhibited	[4][9]
Mycobacterium tuberculosis	H37Rv	0.032 - 0.063	[5][8]
Various Gram-positive bacteria	(130 out of 138 strains)	Inhibited	[4][9]
Various Gram-negative bacteria	(37 strains)	No inhibition	[4][9]

Mechanism of Action: Inhibition of Protein Synthesis

Micrococcin P1 exerts its bactericidal and bacteriostatic effects by inhibiting bacterial protein synthesis.[3][5] It specifically targets the 50S subunit of the bacterial ribosome, a critical component of the protein synthesis machinery.[7]

The binding site for **Micrococcin P1** is a conserved cleft formed between the ribosomal protein L11 and a specific domain of the 23S rRNA.[5] By occupying this critical site, the antibiotic sterically hinders the binding and function of essential elongation factors, namely Elongation Factor G (EF-G) and Elongation Factor Tu (EF-Tu).[5] This interference effectively stalls the translocation step of protein synthesis, where the ribosome moves along the mRNA template. The ultimate consequence is the cessation of polypeptide chain elongation, leading to the inhibition of bacterial growth and, in some cases, cell death.

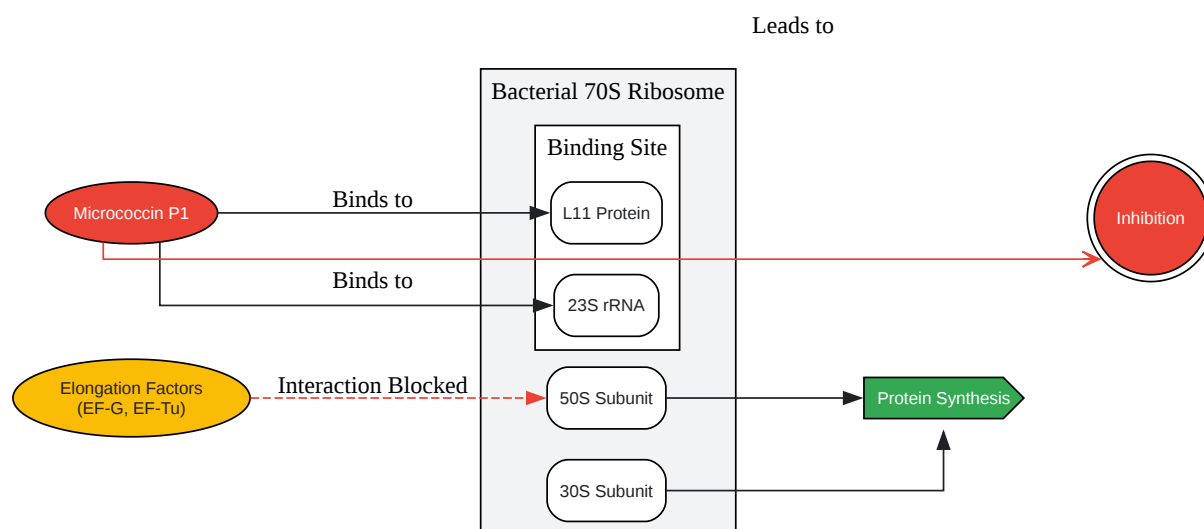

[Click to download full resolution via product page](#)

Inhibition of bacterial protein synthesis by **Micrococcin P1**.

Biosynthesis of Micrococcin P1

Micrococcin P1 is a RiPP, meaning it is synthesized by the ribosome as a precursor peptide, which then undergoes extensive post-translational modifications by a dedicated suite of enzymes.[1][10] The genes responsible for the biosynthesis of **Micrococcin P1** are typically located together in a biosynthetic gene cluster (BGC).[10]

The biosynthesis can be broadly divided into several key steps:

- **Ribosomal Synthesis of the Precursor Peptide:** A precursor peptide, often designated as TcIE, is synthesized by the ribosome. This peptide contains a leader peptide at its N-terminus, which is crucial for recognition by the modification enzymes, and a core peptide that will be modified to form the final antibiotic.
- **Formation of Thiazole Rings:** Cysteine residues within the core peptide undergo cyclodehydration and subsequent oxidation to form thiazole rings. This process is catalyzed by a complex of enzymes.
- **Dehydration of Serine and Threonine Residues:** Serine and threonine residues are dehydrated to form dehydroalanine and dehydrobutyrine, respectively.
- **Macrocyclization and Pyridine Ring Formation:** A key step involves the formation of a central pyridine ring, which is a hallmark of many thiopeptide antibiotics. This is followed by macrocyclization of the peptide backbone.
- **C-terminal Reduction:** A tailoring enzyme, TcIS, catalyzes a C-terminal reduction, which distinguishes **Micrococcin P1** from the related compound, Micrococcin P2.[4]
- **Leader Peptide Cleavage:** Finally, the leader peptide is cleaved off to release the mature and active **Micrococcin P1**.

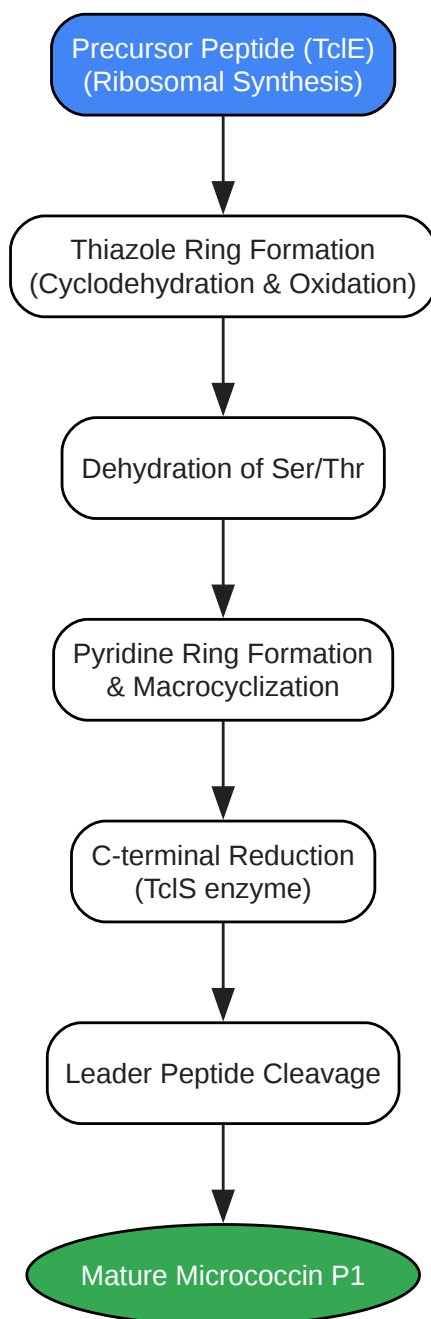

[Click to download full resolution via product page](#)

Simplified biosynthetic pathway of **Micrococцин P1**.

Experimental Protocols

Purification of Micrococцин P1

This protocol is adapted from methods described for the purification of **Micrococцин P1** from bacterial culture.^{[4][7]}

Materials:

- Bacterial culture producing **Micrococcin P1** (e.g., *Staphylococcus equorum*)
- Brain Heart Infusion (BHI) broth
- Ammonium sulfate
- Sodium phosphate buffer (50 mM, pH 7.0)
- Trifluoroacetic acid (TFA)
- Acetonitrile
- Reversed-phase chromatography column (e.g., C18)
- HPLC system
- Centrifuge

Procedure:

- Cultivation: Inoculate the producing bacterial strain in BHI broth and incubate at 30-37°C for 24-96 hours.[4][7]
- Cell Removal: Pellet the bacterial cells by centrifugation (e.g., 10,000-12,000 x g for 15-20 minutes at 4°C). The supernatant contains the secreted **Micrococcin P1**. [4][7]
- Ammonium Sulfate Precipitation: Slowly add ammonium sulfate to the supernatant to a final saturation of 40-80%, while stirring at 4°C. Allow precipitation to occur overnight.
- Collection and Resuspension: Centrifuge to collect the precipitate. Resuspend the pellet in a minimal volume of 50 mM sodium phosphate buffer (pH 7.0). [4]
- Reversed-Phase Chromatography:
 - Equilibrate a C18 reversed-phase column with buffer A (0.1% TFA in water). [4]
 - Load the resuspended sample onto the column.

- Wash the column with buffer A to remove unbound impurities.
- Elute **Micrococcin P1** using a linear gradient of buffer B (0.1% TFA in acetonitrile). **Micrococcin P1** is expected to elute at a high concentration of acetonitrile due to its hydrophobicity.^[4]
- HPLC Purification: For higher purity, subject the fractions containing **Micrococcin P1** to a final purification step using reversed-phase high-performance liquid chromatography (RP-HPLC) with a suitable gradient of acetonitrile in water with 0.1% TFA.
- Verification: Confirm the identity and purity of the isolated **Micrococcin P1** using mass spectrometry and NMR spectroscopy.

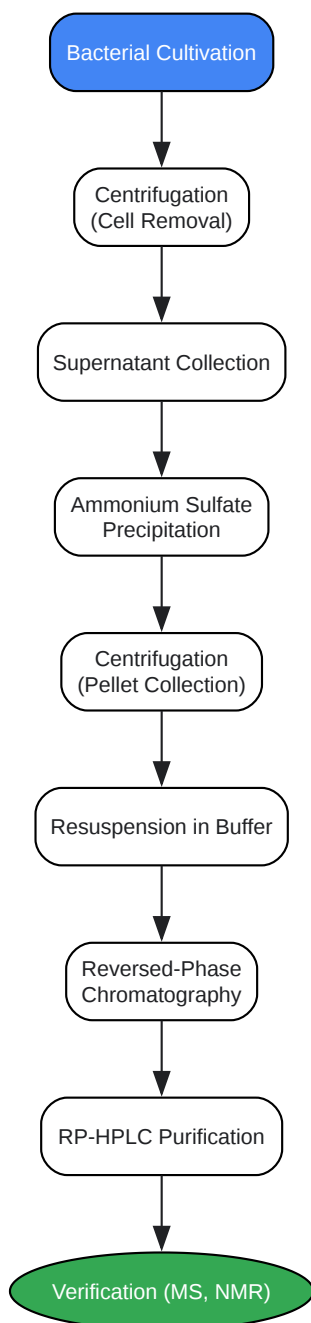

[Click to download full resolution via product page](#)

Experimental workflow for the purification of **Micrococcin P1**.

Determination of Minimum Inhibitory Concentration (MIC) by Broth Microdilution

This protocol is based on the guidelines from the Clinical and Laboratory Standards Institute (CLSI).^{[6][11][12]}

Materials:

- Purified **Micrococcin P1**
- Cation-adjusted Mueller-Hinton Broth (CAMHB)
- Sterile 96-well microtiter plates
- Test bacterial strains
- 0.5 McFarland turbidity standard
- Spectrophotometer or densitometer
- Incubator

Procedure:

- Inoculum Preparation:
 - From a fresh (18-24 hour) culture of the test bacterium on a non-selective agar plate, pick several colonies and suspend them in sterile saline or broth.
 - Adjust the turbidity of the bacterial suspension to match the 0.5 McFarland standard (approximately $1-2 \times 10^8$ CFU/mL).[6] This can be done visually or with a spectrophotometer.
 - Dilute this suspension in CAMHB to achieve a final inoculum concentration of approximately 5×10^5 CFU/mL in each well of the microtiter plate.[6]
- Preparation of **Micrococcin P1** Dilutions:
 - Dispense 50 μ L of sterile CAMHB into wells 2 through 12 of a 96-well plate.
 - Add 100 μ L of the highest concentration of **Micrococcin P1** to be tested into well 1.
 - Perform a two-fold serial dilution by transferring 50 μ L from well 1 to well 2, mixing, and then transferring 50 μ L from well 2 to well 3, and so on, until well 10. Discard 50 μ L from

well 10.

- Well 11 serves as the growth control (no antibiotic).
- Well 12 serves as the sterility control (no bacteria).
- Inoculation: Inoculate each well (except the sterility control) with 50 μL of the standardized bacterial suspension. The final volume in each well will be 100 μL .
- Incubation: Cover the plate and incubate at 35 ± 2 °C for 16-20 hours in ambient air.
- Reading the MIC: The MIC is the lowest concentration of **Micrococcin P1** at which there is no visible growth of the bacteria. This can be determined by visual inspection or using a microplate reader.

Conclusion

Micrococcin P1 remains a thiopeptide of significant interest due to its potent activity against a variety of Gram-positive pathogens, including those with acquired resistance to conventional antibiotics. Its unique mechanism of action, targeting a conserved site on the bacterial ribosome, presents a promising avenue for the development of new antibacterial agents. The information provided in this technical guide, from quantitative antimicrobial data to detailed experimental protocols and visual pathways, is intended to serve as a valuable resource for researchers and drug development professionals working to unlock the full therapeutic potential of this remarkable natural product. Further research into its in vivo efficacy, safety profile, and potential for synergistic combinations with other antibiotics will be crucial in advancing **Micrococcin P1** towards clinical application.[7][13]

Need Custom Synthesis?

BenchChem offers custom synthesis for rare earth carbides and specific isotopic labeling.

Email: info@benchchem.com or [Request Quote Online](#).

References

- [1. researchgate.net \[researchgate.net\]](#)

- [2. Micrococcin P1 | AgriBiotix \[agribiotix.com\]](#)
- [3. researchgate.net \[researchgate.net\]](#)
- [4. The Macrocyclic Peptide Antibiotic Micrococcin P1 Is Secreted by the Food-Borne Bacterium Staphylococcus equorum WS 2733 and Inhibits Listeria monocytogenes on Soft Cheese - PMC \[pmc.ncbi.nlm.nih.gov\]](#)
- [5. Micrococcin P1 - A bactericidal thiopeptide active against Mycobacterium tuberculosis - PubMed \[pubmed.ncbi.nlm.nih.gov\]](#)
- [6. benchchem.com \[benchchem.com\]](#)
- [7. Frontiers | A Strong Synergy Between the Thiopeptide Bacteriocin Micrococcin P1 and Rifampicin Against MRSA in a Murine Skin Infection Model \[frontiersin.org\]](#)
- [8. medchemexpress.com \[medchemexpress.com\]](#)
- [9. The macrocyclic peptide antibiotic micrococcin P\(1\) is secreted by the food-borne bacterium Staphylococcus equorum WS 2733 and inhibits Listeria monocytogenes on soft cheese - PubMed \[pubmed.ncbi.nlm.nih.gov\]](#)
- [10. Genome-Based Characterization of a Plasmid-Associated Micrococcin P1 Biosynthetic Gene Cluster and Virulence Factors in Mammaliococcus sciuri IMDO-S72 - PMC \[pmc.ncbi.nlm.nih.gov\]](#)
- [11. M07 | Methods for Dilution Antimicrobial Susceptibility Tests for Bacteria That Grow Aerobically \[clsi.org\]](#)
- [12. researchgate.net \[researchgate.net\]](#)
- [13. Detection and evaluation of the antimicrobial activity of Micrococcin P1 isolated from commensal and environmental staphylococcal isolates against MRSA - PubMed \[pubmed.ncbi.nlm.nih.gov\]](#)
- To cite this document: BenchChem. [Micrococcin P1: A Technical Guide for Researchers]. BenchChem, [2026]. [Online PDF]. Available at: [\[https://www.benchchem.com/product/b10765555/docs#micrococcin-p1-a-technical-guide-for-researchers\]](https://www.benchchem.com/product/b10765555/docs#micrococcin-p1-a-technical-guide-for-researchers)

Disclaimer & Data Validity:

The information provided in this document is for Research Use Only (RUO) and is strictly not intended for diagnostic or therapeutic procedures. While BenchChem strives to provide accurate protocols, we make no warranties, express or implied, regarding the fitness of this product for every specific experimental setup.

Technical Support: The protocols provided are for reference purposes. Unsure if this reagent suits your experiment?

Need Industrial/Bulk Grade? [Request Custom Synthesis Quote](#)

BenchChem

Our mission is to be the trusted global source of essential and advanced chemicals, empowering scientists and researchers to drive progress in science and industry.

Contact

Address: 3281 E Guasti Rd
Ontario, CA 91761, United States
Phone: (601) 213-4426
Email: info@benchchem.com

[Contact our Ph.D. Support Team for a compatibility check](#)