

A Comparative Analysis of Micrococcin P1 and Linezolid Against Resistant Bacteria

Author: BenchChem Technical Support Team. **Date:** May 2026

Compound of Interest

Compound Name: *Micrococcin P1*

Cat. No.: *B10765555*

[Get Quote](#)

For Researchers, Scientists, and Drug Development Professionals

This guide provides a detailed comparison of the efficacy of the thiopeptide antibiotic, **Micrococcin P1**, and the oxazolidinone antibiotic, linezolid, against clinically significant resistant Gram-positive bacteria. The information presented is compiled from various in vitro studies to offer a comprehensive overview for research and drug development purposes.

Disclaimer: To date, publicly available research does not include a direct head-to-head comparative study of **Micrococcin P1** and linezolid against the same panel of resistant bacterial isolates under identical experimental conditions. Therefore, the data presented below is a compilation from separate studies and should be interpreted as an indirect comparison.

Executive Summary

Both **Micrococcin P1** and linezolid demonstrate potent activity against a range of resistant Gram-positive pathogens, including methicillin-resistant *Staphylococcus aureus* (MRSA) and vancomycin-resistant enterococci (VRE). Both antibiotics inhibit protein synthesis by targeting the 50S ribosomal subunit, albeit through different mechanisms. This distinct mechanistic action for each compound is a key consideration in the context of potential resistance development.

Mechanism of Action

Micrococccin P1 and linezolid both exert their antibacterial effects by inhibiting protein synthesis, a fundamental process for bacterial growth and replication. However, they target different stages of this process.

Micrococccin P1: This thiopeptide antibiotic binds to a cleft on the bacterial 50S ribosomal subunit formed by the 23S rRNA and ribosomal protein L11. This binding obstructs the site for elongation factor G (EF-G), a crucial component for the translocation of tRNA and mRNA during protein synthesis. By preventing the binding of EF-G, **Micrococccin P1** effectively stalls the elongation of the polypeptide chain.

Linezolid: As an oxazolidinone, linezolid binds to the 23S rRNA of the 50S ribosomal subunit. Its unique binding site interferes with the formation of the 70S initiation complex, which is the very first step of protein synthesis. By preventing the assembly of a functional ribosome, linezolid halts the initiation of protein production.

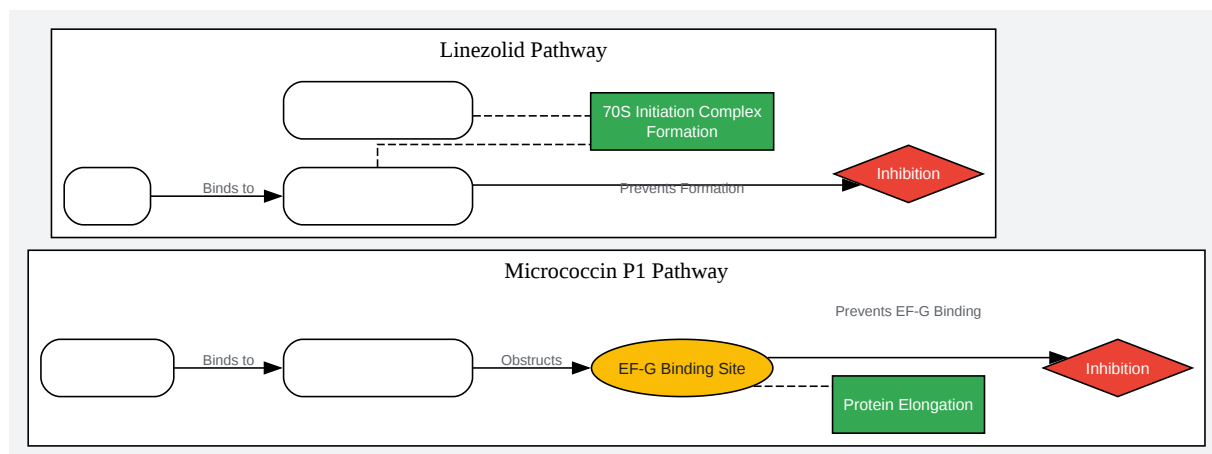

[Click to download full resolution via product page](#)

Figure 1: Comparative Mechanism of Action

Quantitative Data: In Vitro Efficacy

The following tables summarize the Minimum Inhibitory Concentration (MIC) values for **Micrococcin P1** and linezolid against various resistant Gram-positive bacteria, as reported in separate studies. MIC is the lowest concentration of an antibiotic that prevents the visible growth of a microorganism.

Table 1: MIC of **Micrococcin P1** against Resistant Bacteria

Bacterial Species	Strain	MIC (µg/mL)
Staphylococcus aureus (MRSA)	Clinical Isolates	0.5 - 1.0
Enterococcus faecalis	1674621	1
Streptococcus pyogenes	1744264	1
Staphylococcus aureus	1974149	2

Data compiled from multiple sources.

Table 2: MIC of Linezolid against Resistant Bacteria

Bacterial Species	Strain Type	No. of Isolates	MIC Range (µg/mL)	MIC50 (µg/mL)	MIC90 (µg/mL)
Staphylococcus aureus (MRSA)	Clinical Isolates	326	0.25 - 1.5	1	2
Enterococcus spp. (VRE)	Clinical Isolates	Not Specified	0.38 - 1.5	Not Reported	Not Reported

Data for MRSA and VRE compiled from a study in Central India^[1].

Experimental Protocols

The following is a generalized experimental protocol for determining the Minimum Inhibitory Concentration (MIC) using the broth microdilution method, a standard procedure in antimicrobial susceptibility testing.

Broth Microdilution Method

- Preparation of Antimicrobial Agent Dilutions:
 - A two-fold serial dilution of the antibiotic (**Micrococcin P1** or linezolid) is prepared in cation-adjusted Mueller-Hinton Broth (CAMHB) within a 96-well microtiter plate.
- Inoculum Preparation:
 - Bacterial colonies from a fresh agar plate are suspended in a saline solution to match the turbidity of a 0.5 McFarland standard.
 - This suspension is then diluted in CAMHB to achieve a final concentration of approximately 5×10^5 colony-forming units (CFU)/mL in each well of the microtiter plate.
- Inoculation and Incubation:
 - Each well containing the serially diluted antibiotic is inoculated with the standardized bacterial suspension.
 - A growth control well (containing bacteria and broth without antibiotic) and a sterility control well (containing only broth) are included.
 - The plate is incubated at 35-37°C for 16-24 hours.
- MIC Determination:
 - The MIC is visually determined as the lowest concentration of the antibiotic at which there is no visible growth of the bacteria. This can also be measured using a microplate reader.

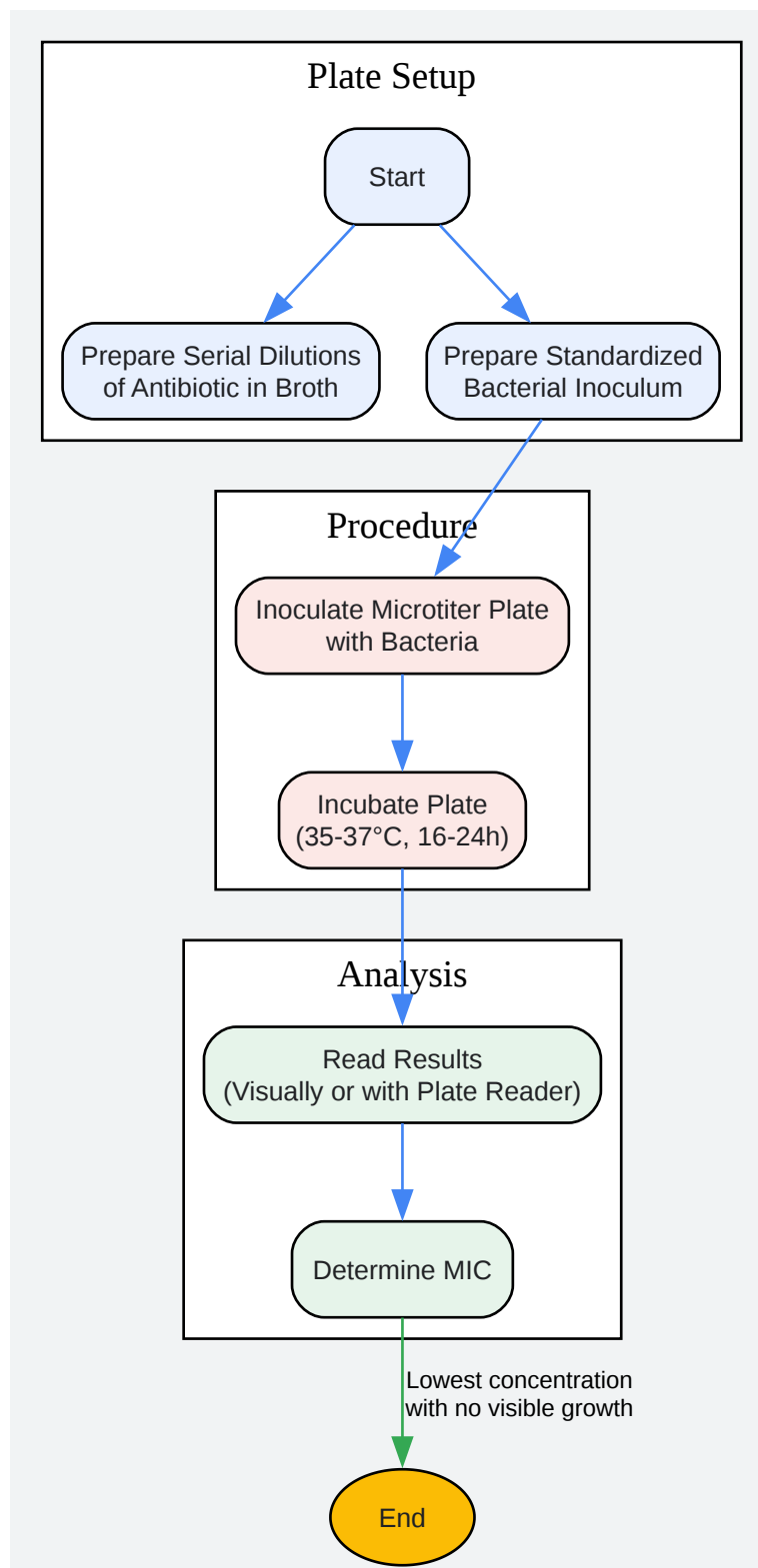

[Click to download full resolution via product page](#)

Figure 2: General Workflow for MIC Determination

Conclusion

Both **Micrococcin P1** and linezolid are potent inhibitors of protein synthesis with demonstrated in vitro activity against multi-drug resistant Gram-positive bacteria. Their distinct mechanisms of action provide a basis for their potential use in combating infections where resistance to other antibiotics is a concern. The lack of direct comparative studies highlights a knowledge gap and underscores the need for future research to directly evaluate the relative efficacy of these two promising antimicrobial agents. Such studies would be invaluable for guiding drug development efforts and informing clinical decisions.

Need Custom Synthesis?

BenchChem offers custom synthesis for rare earth carbides and specific isotopic labeling.

Email: info@benchchem.com or [Request Quote Online](#).

References

- [1. In vitro activity of daptomycin & linezolid against methicillin resistant Staphylococcus aureus & vancomycin resistant enterococci isolated from hospitalized cases in Central India - PMC \[pmc.ncbi.nlm.nih.gov\]](#)
- To cite this document: BenchChem. [A Comparative Analysis of Micrococcin P1 and Linezolid Against Resistant Bacteria]. BenchChem, [2026]. [Online PDF]. Available at: [\[https://www.benchchem.com/product/b10765555/docs#a-comparative-analysis-of-micrococcin-p1-and-linezolid-against-resistant-bacteria\]](https://www.benchchem.com/product/b10765555/docs#a-comparative-analysis-of-micrococcin-p1-and-linezolid-against-resistant-bacteria)

Disclaimer & Data Validity:

The information provided in this document is for Research Use Only (RUO) and is strictly not intended for diagnostic or therapeutic procedures. While BenchChem strives to provide accurate protocols, we make no warranties, express or implied, regarding the fitness of this product for every specific experimental setup.

Technical Support: The protocols provided are for reference purposes. Unsure if this reagent suits your experiment?

Need Industrial/Bulk Grade? [Request Custom Synthesis Quote](#)

BenchChem

Our mission is to be the trusted global source of essential and advanced chemicals, empowering scientists and researchers to drive progress in science and industry.

Contact

Address: 3281 E Guasti Rd
Ontario, CA 91761, United States
Phone: (601) 213-4426
Email: info@benchchem.com

[Contact our Ph.D. Support Team for a compatibility check](#)