

Troubleshooting CEP-28122 experimental variability

Author: BenchChem Technical Support Team. **Date:** May 2026

Compound of Interest

Compound Name: CEP-28122

Cat. No.: B10764694

[Get Quote](#)

CEP-28122 Technical Support Center

Welcome to the technical support center for **CEP-28122**. This resource is designed for researchers, scientists, and drug development professionals to provide guidance and troubleshoot potential experimental variability when working with this potent and selective ALK inhibitor.

Frequently Asked Questions (FAQs)

Q1: What is **CEP-28122** and what is its primary mechanism of action?

CEP-28122 is a highly potent and selective, orally active small molecule inhibitor of Anaplastic Lymphoma Kinase (ALK).^{[1][2][3][4][5]} Its primary mechanism of action is the inhibition of ALK's kinase activity, which in turn blocks the downstream signaling pathways that are constitutively activated in various cancers due to ALK genetic alterations.^{[2][3]} This inhibition of ALK tyrosine phosphorylation leads to growth inhibition and cytotoxicity in ALK-positive cancer cells.^{[2][3]}

Q2: In which cancer models has **CEP-28122** shown efficacy?

Preclinical studies have demonstrated the antitumor activity of **CEP-28122** in various ALK-positive cancer models, including:

- Anaplastic Large-Cell Lymphoma (ALCL)[2]
- Non-Small Cell Lung Cancer (NSCLC)[1][2]
- Neuroblastoma[2]

In mouse xenograft models of these cancers, orally administered **CEP-28122** has been shown to induce dose-dependent tumor regression.[1][2]

Q3: What are the recommended starting concentrations for in vitro cell-based assays?

Based on preclinical data, **CEP-28122** has shown activity in the low nanomolar range. For cell-based assays, a starting concentration range of 3 nM to 3000 nM is suggested for generating dose-response curves.[3] It is crucial to perform a dose-response experiment to determine the optimal concentration for your specific cell line and assay conditions.

Q4: How should **CEP-28122** be prepared and stored?

For in vitro experiments, **CEP-28122** is typically dissolved in dimethyl sulfoxide (DMSO) to create a stock solution. It is critical to keep the final DMSO concentration consistent across all experimental and control wells, as DMSO can impact kinase activity. For storage, follow the manufacturer's recommendations, which generally involve storing the compound as a solid at -20°C and the DMSO stock solution in aliquots at -20°C or -80°C to minimize freeze-thaw cycles.

Troubleshooting Experimental Variability

Variability in experimental results can arise from multiple sources. This section provides a guide to identifying and mitigating common issues encountered during in vitro and in vivo experiments with **CEP-28122**.

In Vitro Assay Variability

Issue 1: High variability in IC50 values between experiments.

| Potential Cause | Troubleshooting Steps |
|-------------------------------|--|
| Inconsistent Incubation Time | Ensure the kinase reaction is within the linear range. Aim for substrate conversion below 20% to maintain initial velocity conditions. |
| Temperature Fluctuations | Use a calibrated incubator and minimize the time plates are outside of the controlled environment. Enzyme activity is highly sensitive to temperature changes. |
| Variable DMSO Concentration | Maintain a consistent final DMSO concentration across all wells. Create a dilution series of CEP-28122 where the DMSO concentration is constant. |
| Inconsistent Reagent Addition | Follow a standardized order of reagent addition for all experiments to minimize variability. |
| Inconsistent Data Analysis | Use a standardized workflow for background subtraction, normalization, and curve fitting to ensure consistency in IC50 determination. |

Issue 2: High variability between replicate wells on the same plate.

| Potential Cause | Troubleshooting Steps |
|-------------------|---|
| Pipetting Errors | Use calibrated pipettes and proper pipetting techniques to ensure accurate volume dispensing. |
| Inadequate Mixing | Ensure thorough but gentle mixing of reagents in the wells after each addition to avoid localized concentration differences. |
| Edge Effects | To mitigate evaporation from outer wells, consider not using the outermost wells of the plate for experimental data or fill them with sterile buffer/media. |

Issue 3: Unexpected or inconsistent positive and negative control results.

| Potential Cause | Troubleshooting Steps |
|--------------------------------|--|
| Low Signal-to-Background Ratio | Optimize enzyme or ATP concentrations. A small difference between positive and negative controls makes it difficult to accurately measure inhibitor effects. |
| Inconsistent Positive Control | This may indicate issues with the stability or activity of the kinase or other key reagents. Ensure proper storage and handling of all reagents. |
| Variable Negative Control | This suggests a problem with the background signal, potentially from detection reagents or compound interference. |

Issue 4: Suspected compound interference.

| Potential Cause | Troubleshooting Steps |
|------------------------------------|--|
| Compound Aggregation | Include a small amount of a non-ionic detergent like Triton X-100 (e.g., 0.01%) in the assay buffer to disrupt aggregates.[6] |
| Interference with Detection System | Run a control experiment with the detection reagents and CEP-28122 but without the kinase to see if the compound directly affects the signal.[6] |

In Vivo Study Variability

Issue 5: Inconsistent tumor growth inhibition in xenograft models.

| Potential Cause | Troubleshooting Steps |
|--|--|
| Variability in Drug Administration | Ensure accurate and consistent oral gavage technique and dosing volume for all animals. |
| Tumor Heterogeneity | Use cell lines with stable ALK expression. Passage number can affect tumor take-rate and growth. |
| Animal Health | Monitor animal health closely, as underlying health issues can impact tumor growth and drug metabolism. |
| Inter-animal Pharmacokinetic Variability | While some variability is expected, significant differences may warrant a review of the animal strain and health status. |

Experimental Protocols

Protocol 1: In Vitro ALK Kinase Inhibition Assay

This protocol outlines a general procedure for determining the IC₅₀ value of **CEP-28122** against recombinant ALK kinase.

- Reagent Preparation:
 - Prepare a 4X solution of **CEP-28122** by serial dilution in assay buffer with a constant DMSO concentration.
 - Prepare a 2X kinase solution containing recombinant ALK enzyme in kinase buffer.
 - Prepare a 4X substrate/ATP solution. The ATP concentration should ideally be at the K_m for ALK.
- Assay Procedure (384-well plate):
 - Add 5 μL of the 4X inhibitor solution to the appropriate wells. For positive controls (100% activity), add 5 μL of buffer with DMSO.

- Add 10 μL of the 2X kinase solution to all wells except the negative controls (0% activity). For negative controls, add 10 μL of 1X kinase buffer.
 - Initiate the reaction by adding 5 μL of the 4X substrate/ATP solution to all wells.
 - Incubate the plate at room temperature for a predetermined time (e.g., 60 minutes), ensuring the reaction is in the linear phase.
 - Stop the reaction and detect the signal. For example, if using an ATP-based detection reagent (like Kinase-Glo®), add 20 μL of the reagent to all wells.
- Data Analysis:
 - Measure luminescence.
 - Subtract the background (negative control).
 - Normalize the data to the positive control (100% activity).
 - Plot the normalized data against the logarithm of the inhibitor concentration and fit to a four-parameter logistic equation to determine the IC₅₀ value.

Visualizations

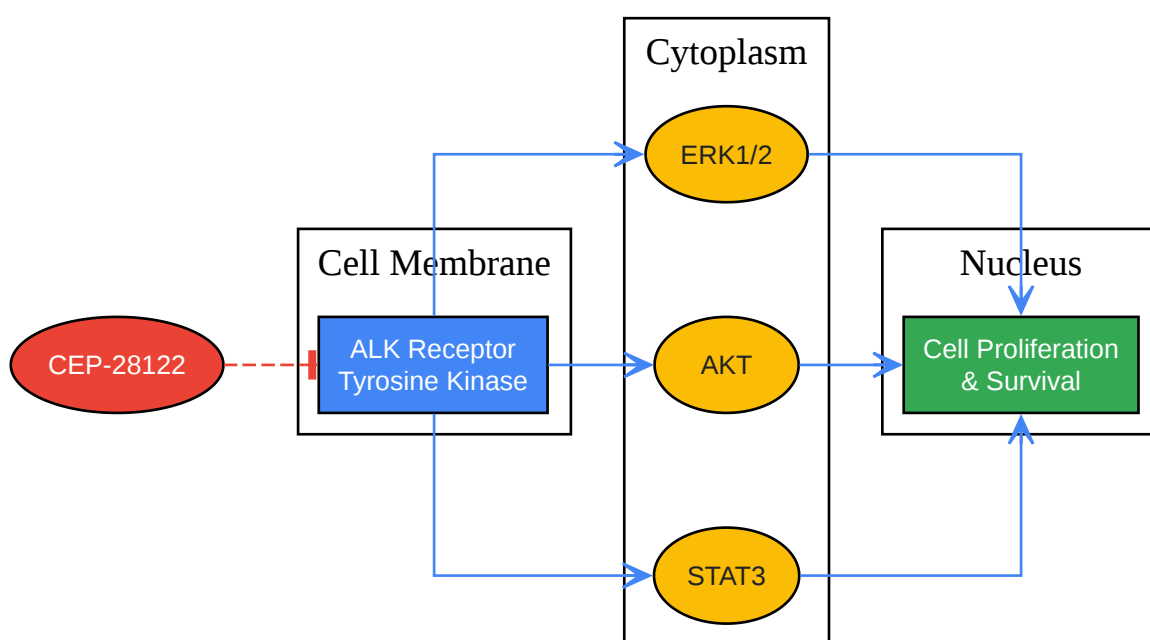

[Click to download full resolution via product page](#)

Caption: Simplified ALK signaling pathway and the inhibitory action of **CEP-28122**.

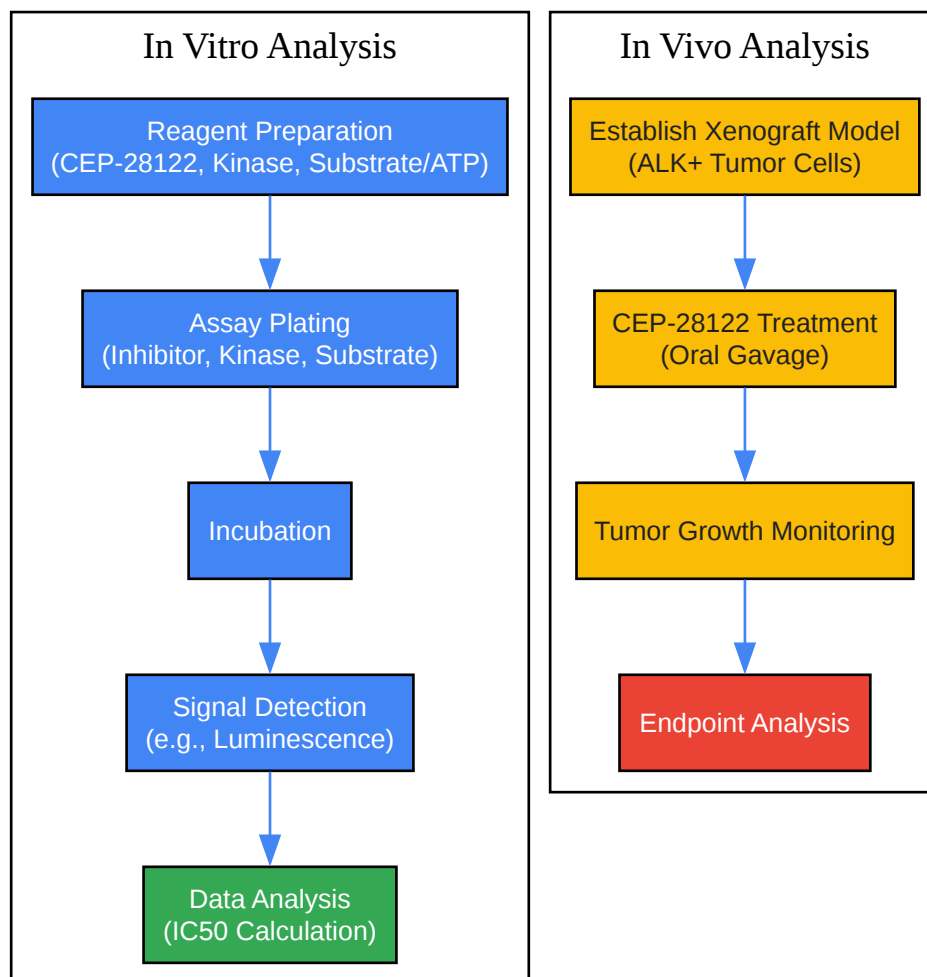

[Click to download full resolution via product page](#)

Caption: General experimental workflow for in vitro and in vivo evaluation of **CEP-28122**.

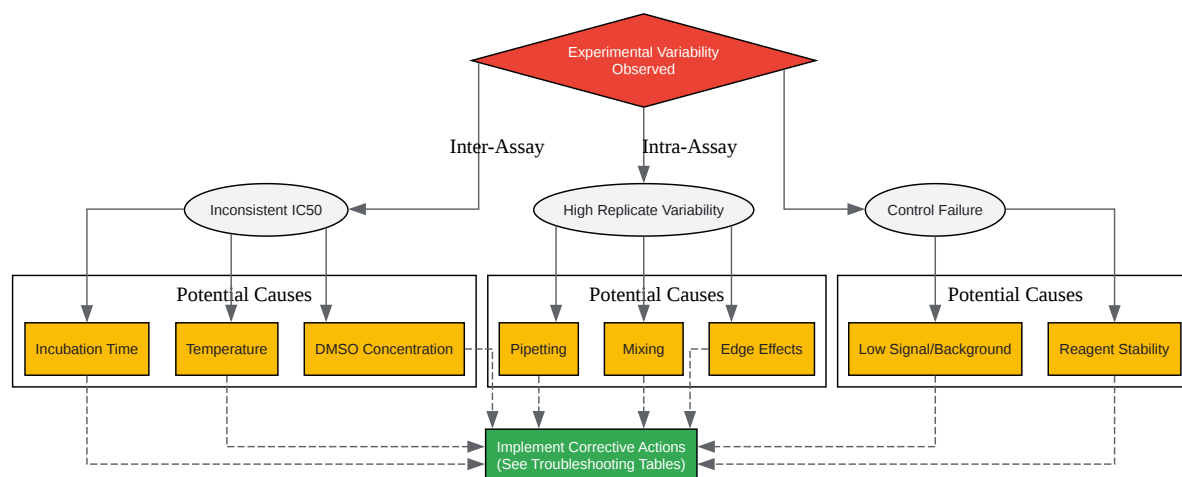

[Click to download full resolution via product page](#)

Caption: Logical flowchart for troubleshooting sources of experimental variability.

Need Custom Synthesis?

BenchChem offers custom synthesis for rare earth carbides and specific isotopic labeling.

Email: info@benchchem.com or [Request Quote Online](#).

References

- 1. aacrjournals.org [aacrjournals.org]
- 2. CEP-28122, a highly potent and selective orally active inhibitor of anaplastic lymphoma kinase with antitumor activity in experimental models of human cancers - PubMed [pubmed.ncbi.nlm.nih.gov]
- 3. medchemexpress.com [medchemexpress.com]

- [4. medchemexpress.com \[medchemexpress.com\]](#)
- [5. medchemexpress.com \[medchemexpress.com\]](#)
- [6. benchchem.com \[benchchem.com\]](#)
- To cite this document: BenchChem. [Troubleshooting CEP-28122 experimental variability]. BenchChem, [2026]. [Online PDF]. Available at: [\[https://www.benchchem.com/product/b10764694/docs#troubleshooting-cep-28122-experimental-variability\]](https://www.benchchem.com/product/b10764694/docs#troubleshooting-cep-28122-experimental-variability)

Disclaimer & Data Validity:

The information provided in this document is for Research Use Only (RUO) and is strictly not intended for diagnostic or therapeutic procedures. While BenchChem strives to provide accurate protocols, we make no warranties, express or implied, regarding the fitness of this product for every specific experimental setup.

Technical Support: The protocols provided are for reference purposes. Unsure if this reagent suits your experiment?

Need Industrial/Bulk Grade? [Request Custom Synthesis Quote](#)

BenchChem

Our mission is to be the trusted global source of essential and advanced chemicals, empowering scientists and researchers to drive progress in science and industry.

Contact

Address: 3281 E Guasti Rd
Ontario, CA 91761, United States
Phone: (601) 213-4426
Email: info@benchchem.com

[Contact our Ph.D. Support Team for a compatibility check](#)

