

Application Notes and Protocols: TM5275 Sodium in a Hepatic Fibrosis Rat Model

Author: BenchChem Technical Support Team. **Date:** April 2026

Compound of Interest

Compound Name: TM5275 sodium

Cat. No.: B10764139

[Get Quote](#)

For Researchers, Scientists, and Drug Development Professionals

Abstract

These application notes provide a detailed overview of the experimental use of **TM5275 sodium**, a novel oral plasminogen activator inhibitor-1 (PAI-1) inhibitor, in attenuating hepatic fibrosis in rat models. The provided protocols are based on established research demonstrating the efficacy of TM5275 in suppressing the activation of hepatic stellate cells (HSCs), key mediators of liver fibrosis. The data herein supports the potential of PAI-1 inhibitors as a therapeutic strategy against nonalcoholic steatohepatitis (NASH)-related hepatic fibrosis.

Introduction

Hepatic fibrosis, characterized by the excessive accumulation of extracellular matrix proteins, is a common outcome of chronic liver injury and can progress to cirrhosis and hepatocellular carcinoma.[1][2] A key event in the development of hepatic fibrosis is the activation of hepatic stellate cells (HSCs), which transform into myofibroblast-like cells that produce large amounts of collagen.[3] Plasminogen activator inhibitor-1 (PAI-1), a primary inhibitor of fibrinolysis, has been implicated in the pathogenesis of fibrosis in various organs, including the liver.[1][4]

Elevated PAI-1 levels are observed in fibrotic livers, and its inhibition presents a promising therapeutic target.

TM5275 is an orally bioavailable small molecule inhibitor of PAI-1. Studies have shown that oral administration of TM5275 can attenuate liver fibrosis in animal models of metabolic syndrome. The mechanism of action involves the suppression of TGF- β 1-induced proliferation and collagen synthesis in HSCs. Specifically, TM5275 has been shown to inhibit the phosphorylation of AKT, a key downstream effector in the TGF- β 1 signaling pathway in HSCs.

These notes provide detailed protocols for inducing hepatic fibrosis in rats and for evaluating the anti-fibrotic effects of TM5275, along with representative data and a visualization of the underlying signaling pathway.

Data Presentation

In Vivo Efficacy of TM5275 in a Choline-Deficient L-Amino-Acid-Defined (CDAA) Diet Rat Model of Steatohepatitis

Parameter	Control	Vehicle	TM5275
Sirius-Red Positive Area (%)	Significantly lower	Markedly increased	Markedly decreased
α -SMA-Immunopositive Area (%)	Significantly lower	Markedly increased	Markedly decreased
Hepatic Tgfb1 mRNA Expression	Baseline	Increased	Decreased
Hepatic Col1a1 mRNA Expression	Baseline	Increased	Decreased
Hepatic TGF- β 1 Protein Level	Baseline	Increased	Reduced
Hepatic Total Collagen Content	Baseline	Increased	Reduced

Data summarized from Noguchi et al., 2020.

In Vivo Efficacy of TM5275 in a Porcine Serum-Induced Diabetic Rat Model of Hepatic Fibrosis

Parameter	Control	Vehicle	TM5275
Sirius-Red Positive Area (%)	Significantly lower	Increased	Decreased
α -SMA-Immunopositive Area (%)	Significantly lower	Increased	Decreased

Data summarized from Noguchi et al., 2020.

In Vitro Effects of TM5275 on Rat Hepatic Stellate Cells (HSC-T6)

Condition	Outcome
HSC-T6 Proliferation (rPAI-1 stimulated)	Suppressed by TM5275
HSC-T6 Proliferation (rTGF- β 1 stimulated)	Suppressed by TM5275 in a dose-dependent manner
rTGF- β 1-induced Serpine1 mRNA Expression	Inhibited by TM5275
rTGF- β 1-induced Tgfb1 mRNA Expression	Repressed by TM5275
rTGF- β 1-induced Col1a1 mRNA Expression	Repressed by TM5275
rTGF- β 1-induced AKT Phosphorylation	Inhibited by TM5275

Data summarized from Noguchi et al., 2020.

Experimental Protocols

CDAA Diet-Induced Steatohepatitis and Fibrosis in Rats

This model induces severe hepatic fibrosis along with steatohepatitis.

Animals:

- Fischer 344 rats.

Protocol:

- Acclimate rats for a minimum of one week before the start of the experiment.
- Divide rats into three groups: Control, Vehicle, and TM5275.
- Feed the Control group a standard diet.
- Feed the Vehicle and TM5275 groups a choline-deficient L-amino-acid-defined (CDAA) diet for 12 weeks to induce steatohepatitis and fibrosis.
- From week 6 to week 12, administer TM5275 (e.g., 200 mg/kg, oral gavage, once daily) to the TM5275 group.
- Administer an equivalent volume of vehicle (e.g., 0.5% carboxymethyl cellulose) to the Vehicle group.
- At the end of the 12-week period, euthanize the rats and collect blood and liver tissue for analysis.
- Histological Analysis: Fix liver tissue in 10% formalin, embed in paraffin, and section. Stain sections with Sirius Red for collagen deposition and perform immunohistochemistry for α -smooth muscle actin (α -SMA) to identify activated HSCs.
- Gene Expression Analysis: Isolate RNA from liver tissue and perform quantitative real-time PCR (qRT-PCR) to measure the mRNA levels of profibrotic genes such as Tgfb1 and Col1a1.
- Protein Analysis: Homogenize liver tissue to measure total collagen content (e.g., Sircol Collagen Assay) and TGF- β 1 protein levels (e.g., ELISA).

Porcine Serum-Induced Hepatic Fibrosis in Diabetic Rats

This model is used to study the anti-fibrotic effects of a compound independent of its metabolic effects.

Animals:

- Otsuka Long-Evans Tokushima Fatty (OLETF) rats (a model of congenital diabetes).

Protocol:

- Acclimate OLETF rats.
- Divide rats into three groups: Control, Vehicle, and TM5275.
- For the Vehicle and TM5275 groups, induce hepatic fibrosis by intraperitoneal injection of porcine serum (e.g., 0.5 ml/rat, twice weekly) for 6 weeks.
- Administer TM5275 (e.g., 200 mg/kg, oral gavage, once daily) to the TM5275 group for the duration of the porcine serum injections.
- Administer an equivalent volume of vehicle to the Vehicle group.
- The Control group receives no porcine serum or treatment.
- At the end of the 6-week period, euthanize the rats and collect liver tissue for histological analysis as described in Protocol 1.

In Vitro Hepatic Stellate Cell (HSC) Assays

These assays are used to investigate the direct effects of TM5275 on HSC activation, proliferation, and fibrogenic activity.

Cell Line:

- HSC-T6 (a rat hepatic stellate cell line).

Protocols:

a) Cell Proliferation Assay:

- Seed HSC-T6 cells in 96-well plates and culture until sub-confluent.
- Starve the cells in serum-free medium for 24 hours.
- Treat the cells with recombinant TGF- β 1 (e.g., 10 ng/ml) or recombinant PAI-1 in the presence or absence of varying concentrations of TM5275 (e.g., 0-100 μ M) for 24-48 hours.
- Assess cell proliferation using a standard method such as the WST-1 or MTT assay.

b) Gene Expression Analysis:

- Seed HSC-T6 cells in 6-well plates and culture to 70-80% confluence.
- Starve the cells in serum-free medium for 24 hours.
- Treat the cells with recombinant TGF- β 1 (e.g., 10 ng/ml) with or without TM5275 (e.g., 100 μ M) for 24 hours.
- Isolate total RNA and perform qRT-PCR to analyze the expression of Serpine1 (the gene encoding PAI-1), Tgfb1, and Col1a1.

c) Western Blot Analysis for Signaling Pathways:

- Culture and starve HSC-T6 cells as described above.
- Pre-treat cells with TM5275 for a specified time before stimulating with recombinant TGF- β 1.
- Lyse the cells at various time points after stimulation.
- Perform Western blot analysis on the cell lysates to detect the phosphorylation status of key signaling proteins such as AKT, ERK1/2, and SMAD2/3.

Visualizations

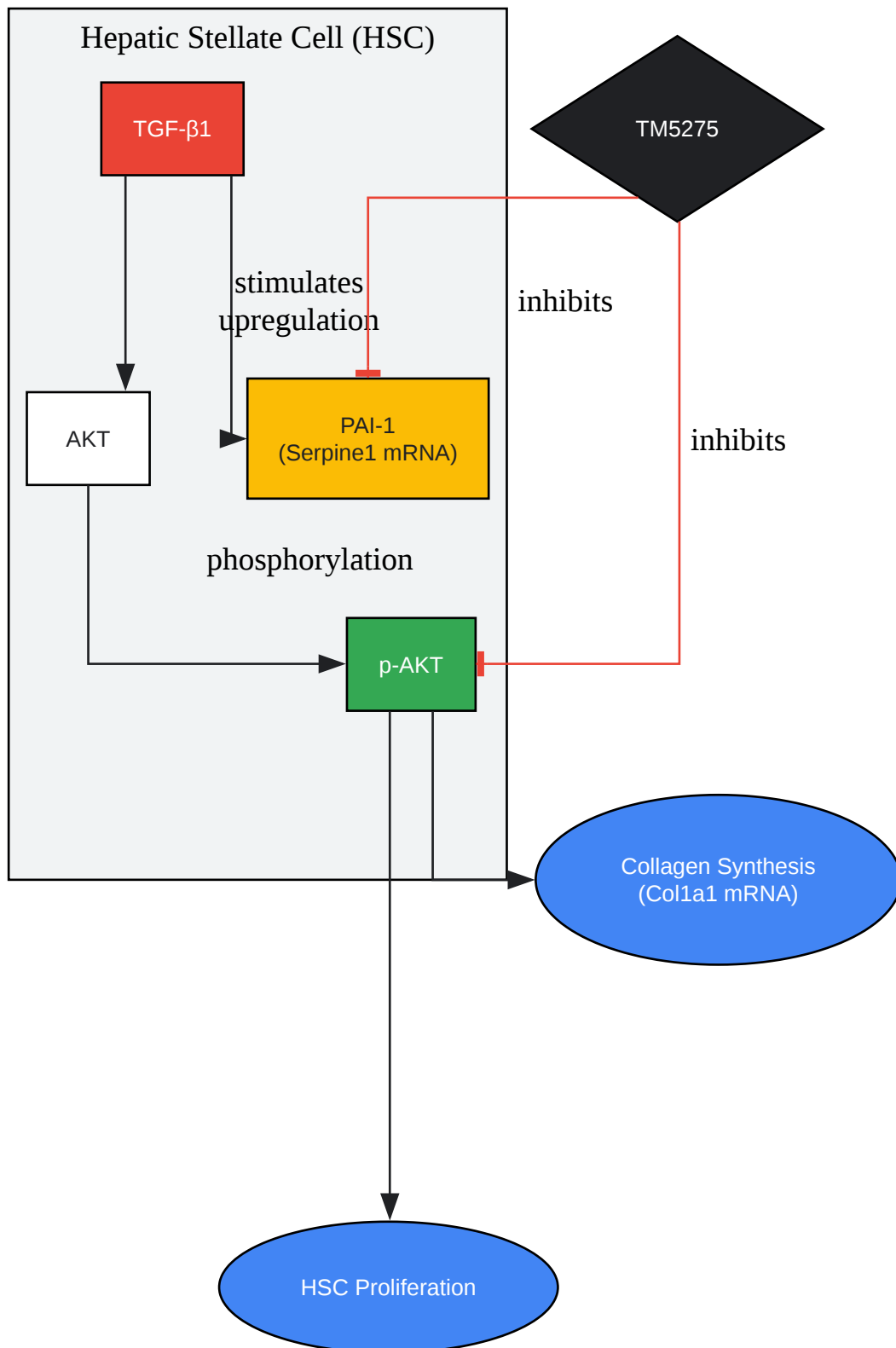

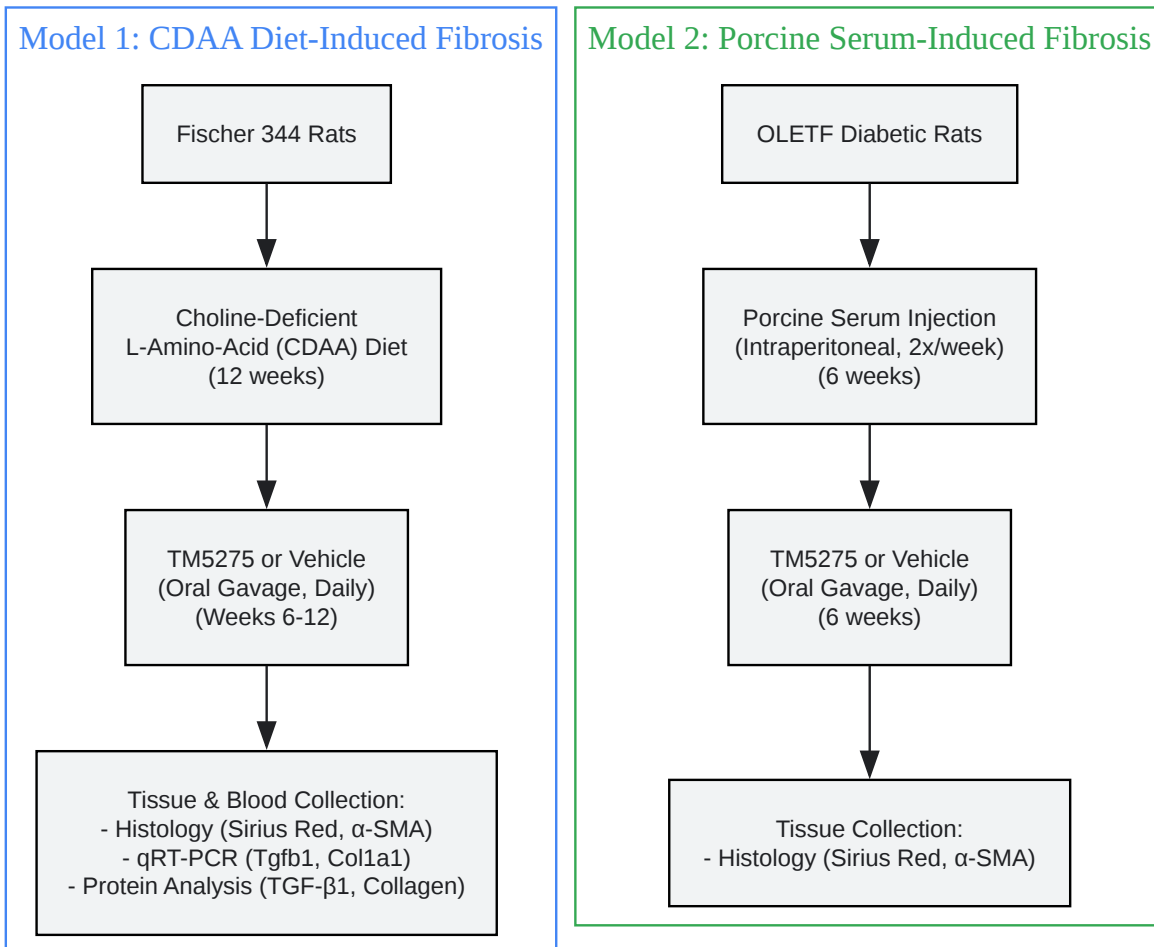

[Click to download full resolution via product page](#)

Need Custom Synthesis?

BenchChem offers custom synthesis for rare earth carbides and specific isotopic labeling.

Email: info@benchchem.com or [Request Quote Online](#).

References

- [1. scientificarchives.com \[scientificarchives.com\]](#)
- [2. scientificarchives.com \[scientificarchives.com\]](#)

- [3. Frontiers | Pharmacological Intervention in Hepatic Stellate Cell Activation and Hepatic Fibrosis \[frontiersin.org\]](#)
- [4. Novel oral plasminogen activator inhibitor-1 inhibitor TM5275 attenuates hepatic fibrosis under metabolic syndrome via suppression of activated hepatic stellate cells in rats - PMC \[pmc.ncbi.nlm.nih.gov\]](#)
- To cite this document: BenchChem. [Application Notes and Protocols: TM5275 Sodium in a Hepatic Fibrosis Rat Model]. BenchChem, [2026]. [Online PDF]. Available at: [\[https://www.benchchem.com/product/b10764139/docs#application-notes-and-protocols-tm5275-sodium-in-a-hepatic-fibrosis-rat-model\]](https://www.benchchem.com/product/b10764139/docs#application-notes-and-protocols-tm5275-sodium-in-a-hepatic-fibrosis-rat-model)

Disclaimer & Data Validity:

The information provided in this document is for Research Use Only (RUO) and is strictly not intended for diagnostic or therapeutic procedures. While BenchChem strives to provide accurate protocols, we make no warranties, express or implied, regarding the fitness of this product for every specific experimental setup.

Technical Support: The protocols provided are for reference purposes. Unsure if this reagent suits your experiment?

Need Industrial/Bulk Grade? [Request Custom Synthesis Quote](#)

BenchChem

Our mission is to be the trusted global source of essential and advanced chemicals, empowering scientists and researchers to drive progress in science and industry.

Contact

Address: 3281 E Guasti Rd
Ontario, CA 91761, United States
Phone: (601) 213-4426
Email: info@benchchem.com

[Contact our Ph.D. Support Team for a compatibility check](#)

