

# NVP-2 vs. Genetic Knockdown of CDK9: A Comparative Guide for Researchers

**Author:** BenchChem Technical Support Team. **Date:** April 2026

## Compound of Interest

Compound Name: NVP-2  
Cat. No.: B10763679

[Get Quote](#)

For researchers, scientists, and drug development professionals, this guide provides an objective comparison of the pharmacological inhibitor **NVP-2** and genetic knockdown techniques for the study of Cyclin-Dependent Kinase 9 (CDK9). This analysis is supported by experimental data to inform the selection of the most appropriate method for specific research applications.

## Introduction

Cyclin-Dependent Kinase 9 (CDK9) is a critical regulator of transcriptional elongation. As the catalytic subunit of the Positive Transcription Elongation Factor b (P-TEFb) complex, CDK9 phosphorylates the C-terminal domain of RNA Polymerase II (RNAPII), facilitating the transition from abortive to productive transcription.<sup>[1][2][3]</sup> This central role in gene expression has made CDK9 a compelling target in various diseases, particularly cancer, where transcriptional addiction is a common feature.<sup>[4][5]</sup> Researchers employ two primary strategies to interrogate CDK9 function: pharmacological inhibition and genetic knockdown. This guide compares a highly potent and selective CDK9 inhibitor, **NVP-2**, with genetic knockdown approaches (e.g., siRNA, shRNA), providing a framework for understanding their respective advantages and limitations.

## Mechanism of Action

**NVP-2:** **NVP-2** is a potent and selective ATP-competitive inhibitor of CDK9.[6][7] It binds to the ATP-binding pocket of CDK9, preventing the transfer of phosphate to its substrates, most notably Serine 2 of the RNAPII C-terminal domain.[4] This inhibition of CDK9's kinase activity leads to a global suppression of transcriptional elongation, particularly affecting genes with short-lived mRNAs, such as the proto-oncogene MYC and the anti-apoptotic factor MCL-1.[6][8] **NVP-2** exhibits sub-nanomolar potency against CDK9 and high selectivity over other kinases, making it a precise tool for studying CDK9 function.[1][6]

**Genetic Knockdown of CDK9:** Genetic knockdown of CDK9, typically achieved through the use of small interfering RNAs (siRNAs) or short hairpin RNAs (shRNAs), results in the degradation of CDK9 mRNA. This leads to a reduction in the total cellular levels of the CDK9 protein.[5][9] Consequently, the overall kinase activity of CDK9 is diminished due to the reduced abundance of the enzyme. This approach offers high specificity for CDK9, assuming the siRNA/shRNA sequences are designed to avoid off-target effects.

## Data Presentation: A Quantitative Comparison

The following tables summarize quantitative data from various studies to facilitate a comparison between **NVP-2** and CDK9 knockdown. It is important to note that direct head-to-head comparisons in the same experimental system are limited, and thus, these tables compile data from different studies.

Table 1: Effect on Cell Viability (IC50)

| Method     | Cell Line                   | IC50                         | Citation |
|------------|-----------------------------|------------------------------|----------|
| NVP-2      | MOLT4 (Leukemia)            | 9 nM                         | [1][6]   |
| NVP-2      | SET-2 (sAML)                | More potent than BAY-1143572 | [4]      |
| NVP-2      | HEL92.1.7 (sAML)            | More potent than BAY-1143572 | [4]      |
| CDK9 siRNA | AN3CA (Endometrial Cancer)  | Dose-dependent decrease      | [10]     |
| CDK9 siRNA | SPAC1S (Endometrial Cancer) | Dose-dependent decrease      | [10]     |
| CDK9 siRNA | SKOV3 (Ovarian Cancer)      | Dose-dependent inhibition    | [9]      |
| CDK9 siRNA | OVCAR8 (Ovarian Cancer)     | Dose-dependent inhibition    | [9]      |

Table 2: Induction of Apoptosis

| Method     | Cell Line        | Assay                         | Result                   | Citation |
|------------|------------------|-------------------------------|--------------------------|----------|
| NVP-2      | MOLT4 (Leukemia) | Annexin V                     | ~100% Annexin V positive | [6]      |
| NVP-2      | SET-2 (sAML)     | Apoptosis Assay               | Dose-dependent induction | [4]      |
| CDK9 siRNA | Kasumi-1 (AML)   | Morphology, Cleaved Caspase-3 | Induced apoptosis        | [5]      |
| CDK9 siRNA | U937 (AML)       | Morphology, Cleaved Caspase-3 | Induced apoptosis        | [5]      |

Table 3: Effect on Downstream Targets

| Method     | Target          | Cell Line                  | Effect               | Citation |
|------------|-----------------|----------------------------|----------------------|----------|
| NVP-2      | p-RNAPII (Ser2) | SET-2,<br>HEL92.1.7        | Decreased            | [4]      |
| NVP-2      | MCL-1           | MOLT4, SET-2,<br>HEL92.1.7 | Decreased<br>protein | [4][6]   |
| NVP-2      | c-Myc           | SET-2,<br>HEL92.1.7        | Decreased<br>protein | [4]      |
| CDK9 siRNA | p-RNAPII (Ser2) | -                          | Decreased            | [4]      |
| CDK9 siRNA | MCL-1           | -                          | Decreased<br>protein | [1]      |
| CDK9 siRNA | c-Myc           | Kasumi-1, U937             | Decreased<br>protein | [5]      |

## Signaling Pathways and Experimental Workflows

To visualize the mechanisms and experimental approaches discussed, the following diagrams are provided in DOT language.

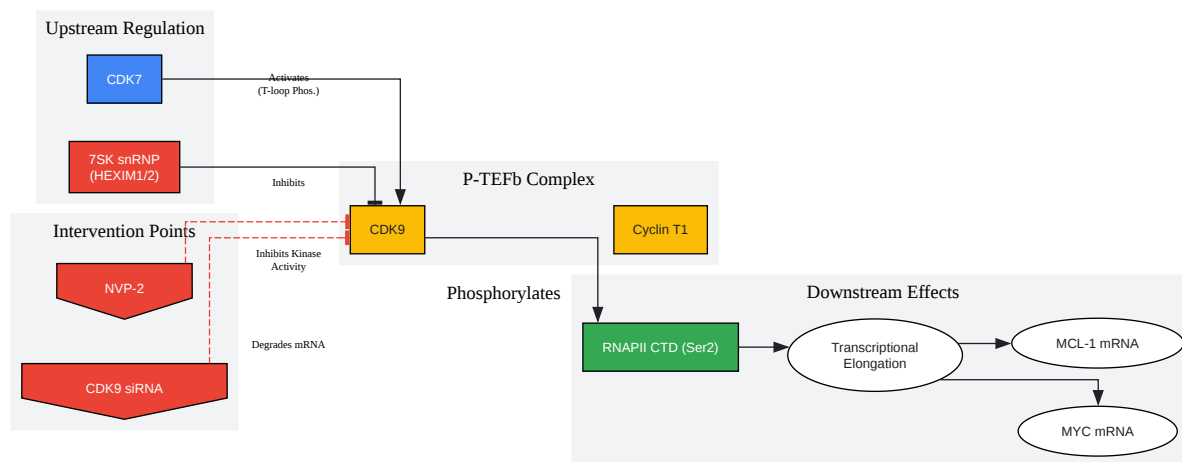

[Click to download full resolution via product page](#)

**Figure 1:** CDK9 Signaling Pathway and Intervention Points.

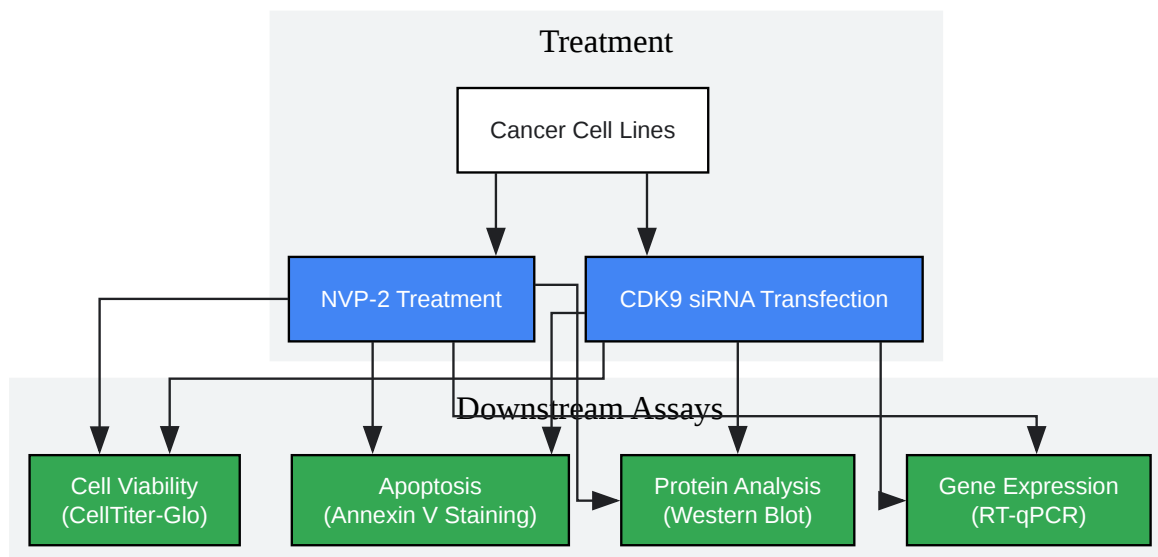

[Click to download full resolution via product page](#)

**Figure 2:** General Experimental Workflow for Comparing **NVP-2** and CDK9 siRNA.

## Experimental Protocols

### Cell Viability Assay (CellTiter-Glo®)

- **Cell Seeding:** Plate cells in an opaque-walled 96-well plate at a density that ensures they are in the logarithmic growth phase at the time of the assay.
- **Treatment:** Treat cells with varying concentrations of **NVP-2** or transfect with CDK9 siRNA and incubate for the desired duration (e.g., 72 hours).
- **Reagent Preparation:** Thaw the CellTiter-Glo® buffer and substrate and allow them to equilibrate to room temperature. Reconstitute the substrate with the buffer to create the CellTiter-Glo® Reagent.
- **Assay Procedure:** Add a volume of CellTiter-Glo® Reagent equal to the volume of cell culture medium in each well.
- **Lysis and Signal Stabilization:** Mix the contents on an orbital shaker for 2 minutes to induce cell lysis. Incubate at room temperature for 10 minutes to stabilize the luminescent signal.

- **Data Acquisition:** Measure the luminescence using a plate reader. The signal is proportional to the amount of ATP, which corresponds to the number of viable cells.

## siRNA Transfection (Using Lipofectamine™ RNAiMAX)

- **Cell Plating:** One day before transfection, seed cells in a 6-well plate in antibiotic-free medium to achieve 70-90% confluency at the time of transfection.
- **Complex Formation:**
  - For each well, dilute the desired amount of CDK9 siRNA (e.g., 50 nM final concentration) in Opti-MEM™ I Reduced Serum Medium.
  - In a separate tube, dilute Lipofectamine™ RNAiMAX in Opti-MEM™ I Reduced Serum Medium.
  - Combine the diluted siRNA and Lipofectamine™ RNAiMAX, mix gently, and incubate for 20 minutes at room temperature to allow for complex formation.
- **Transfection:** Add the siRNA-lipid complexes to the cells.
- **Incubation:** Incubate the cells at 37°C in a CO2 incubator for 48-72 hours before proceeding with downstream assays.

## Western Blot Analysis

- **Cell Lysis:** After treatment with **NVP-2** or transfection with CDK9 siRNA, wash cells with ice-cold PBS and lyse with RIPA buffer supplemented with protease and phosphatase inhibitors.
- **Protein Quantification:** Determine the protein concentration of the lysates using a BCA assay.
- **Sample Preparation:** Normalize protein concentrations and add Laemmli sample buffer. Boil the samples at 95°C for 5 minutes.
- **SDS-PAGE and Transfer:** Load equal amounts of protein onto an SDS-PAGE gel. After electrophoresis, transfer the proteins to a PVDF membrane.

- **Blocking and Antibody Incubation:** Block the membrane with 5% non-fat milk or BSA in TBST for 1 hour at room temperature. Incubate the membrane with primary antibodies against CDK9, Phospho-RNAPII (Ser2), MCL-1, c-Myc, and a loading control (e.g., GAPDH or  $\beta$ -actin) overnight at 4°C.
- **Secondary Antibody and Detection:** Wash the membrane with TBST and incubate with an appropriate HRP-conjugated secondary antibody for 1 hour at room temperature. Visualize the protein bands using an ECL substrate and an imaging system.

## Apoptosis Assay (Annexin V Staining)

- **Cell Harvesting:** Following treatment, collect both adherent and floating cells.
- **Washing:** Wash the cells twice with cold PBS.
- **Resuspension:** Resuspend the cells in 1X Annexin V Binding Buffer.
- **Staining:** Add Annexin V-FITC and Propidium Iodide (PI) to the cell suspension.
- **Incubation:** Incubate the cells for 15 minutes at room temperature in the dark.
- **Analysis:** Analyze the cells by flow cytometry. Early apoptotic cells will be Annexin V positive and PI negative, while late apoptotic/necrotic cells will be positive for both.

## Quantitative RT-PCR (for MYC and MCL1 expression)

- **RNA Extraction:** Isolate total RNA from treated and control cells using a suitable kit.
- **cDNA Synthesis:** Synthesize first-strand cDNA from the RNA samples.
- **qPCR Reaction:** Prepare the qPCR reaction mix with a SYBR Green master mix, gene-specific primers for MYC, MCL1, and a housekeeping gene (e.g., GAPDH), and the cDNA template.
- **Data Analysis:** Run the reaction on a real-time PCR system. Calculate the relative gene expression using the  $\Delta\Delta C_t$  method.[\[11\]](#)

## Conclusion

Both **NVP-2** and genetic knockdown are powerful tools for investigating the function of CDK9. **NVP-2** offers the advantage of rapid, dose-dependent, and reversible inhibition of CDK9's kinase activity, making it suitable for studying the acute effects of CDK9 inhibition and for preclinical therapeutic evaluations.[4][6] Genetic knockdown provides a highly specific means to deplete the CDK9 protein, which is valuable for validating the on-target effects of inhibitors and for studying the long-term consequences of CDK9 loss.[5]

The choice between these two approaches will depend on the specific research question. For instance, to study the immediate transcriptional consequences of blocking CDK9's catalytic function, **NVP-2** is an excellent choice. To confirm that a phenotype observed with an inhibitor is indeed due to the targeting of CDK9, a genetic knockdown experiment is the gold standard. A combined approach, where findings from pharmacological inhibition are validated by genetic knockdown, will provide the most robust and comprehensive understanding of CDK9's role in biological processes.

#### *Need Custom Synthesis?*

*BenchChem offers custom synthesis for rare earth carbides and specific isotopic labeling.*

*Email: [info@benchchem.com](mailto:info@benchchem.com) or [Request Quote Online](#).*

## References

- [1. Targeting CDK9 for Anti-Cancer Therapeutics - PMC \[pmc.ncbi.nlm.nih.gov\]](#)
- [2. pnas.org \[pnas.org\]](#)
- [3. Cyclin dependent kinase 9 inhibitor induces transcription-replication conflicts and DNA damage accumulation in breast cancer - PMC \[pmc.ncbi.nlm.nih.gov\]](#)
- [4. Efficacy of CDK9 inhibition in therapy of post-myeloproliferative neoplasm \(MPN\) secondary \(s\) AML cells - PMC \[pmc.ncbi.nlm.nih.gov\]](#)
- [5. NVP-2, in combination with Orlistat, represents a promising therapeutic strategy for acute myeloid leukemia - PMC \[pmc.ncbi.nlm.nih.gov\]](#)
- [6. Pharmacological perturbation of CDK9 using selective CDK9 inhibition or degradation - PMC \[pmc.ncbi.nlm.nih.gov\]](#)
- [7. researchgate.net \[researchgate.net\]](#)
- [8. benchchem.com \[benchchem.com\]](#)

- [9. researchgate.net \[researchgate.net\]](#)
- [10. spandidos-publications.com \[spandidos-publications.com\]](#)
- [11. Targeting CDK9 and MCL-1 by a new CDK9/p-TEFb inhibitor with and without 5-fluorouracil in esophageal adenocarcinoma - PMC \[pmc.ncbi.nlm.nih.gov\]](#)
- To cite this document: BenchChem. [NVP-2 vs. Genetic Knockdown of CDK9: A Comparative Guide for Researchers]. BenchChem, [2026]. [Online PDF]. Available at: [\[https://www.benchchem.com/product/b10763679/docs#nvp-2-vs-genetic-knockdown-of-cdk9-a-comparative-guide-for-researchers\]](https://www.benchchem.com/product/b10763679/docs#nvp-2-vs-genetic-knockdown-of-cdk9-a-comparative-guide-for-researchers)

---

### Disclaimer & Data Validity:

The information provided in this document is for Research Use Only (RUO) and is strictly not intended for diagnostic or therapeutic procedures. While BenchChem strives to provide accurate protocols, we make no warranties, express or implied, regarding the fitness of this product for every specific experimental setup.

**Technical Support:** The protocols provided are for reference purposes. Unsure if this reagent suits your experiment?

**Need Industrial/Bulk Grade?** [Request Custom Synthesis Quote](#)

## BenchChem

Our mission is to be the trusted global source of essential and advanced chemicals, empowering scientists and researchers to drive progress in science and industry.

### Contact

Address: 3281 E Guasti Rd  
Ontario, CA 91761, United States  
Phone: (601) 213-4426  
Email: [info@benchchem.com](mailto:info@benchchem.com)

[Contact our Ph.D. Support Team for a compatibility check](#)

