

Determining the Optimal Concentration of ML350: Application Notes and Protocols

Author: BenchChem Technical Support Team. **Date:** April 2026

Compound of Interest

Compound Name: ML350
Cat. No.: B10763790

[Get Quote](#)

These application notes provide a comprehensive guide for researchers, scientists, and drug development professionals to determine the optimal experimental concentration of **ML350**, a potent and selective Kappa Opioid Receptor (KOR) antagonist.

Introduction to ML350

ML350 is a highly selective antagonist for the Kappa Opioid Receptor (KOR), a G protein-coupled receptor involved in various physiological processes including pain, mood, and addiction.[1][2] As a KOR antagonist, **ML350** blocks the receptor's activation by endogenous ligands like dynorphins or exogenous agonists, thereby inhibiting downstream signaling cascades.[1][3][4] Its favorable pharmacokinetic properties, including high solubility and central nervous system penetration, make it a valuable tool for in vitro and in vivo studies.[3][4]

Quantitative Data for ML350

The inhibitory potency of **ML350** is typically reported as its half-maximal inhibitory concentration (IC₅₀). This value represents the concentration of the antagonist required to inhibit 50% of the receptor's response to an agonist. The reported IC₅₀ values for **ML350** against the Kappa Opioid Receptor are summarized below.

Target Receptor	Reported IC50 Range (nM)	Specific IC50 Value (nM)	Selectivity Notes
Kappa Opioid Receptor (KOR/OPRK1)	9 - 16	12.6	219-382 fold selective over DOR and 20-35 fold selective over MOR.[4]

IC50 values can vary depending on the specific assay conditions, such as agonist concentration and cell type used.

Signaling Pathway of the Kappa Opioid Receptor (KOR)

The Kappa Opioid Receptor is a Gi/Go-coupled G protein-coupled receptor (GPCR).[2][5] Upon activation by an agonist, the Gi/Go protein dissociates, leading to the inhibition of adenylyl cyclase, which in turn decreases intracellular cyclic AMP (cAMP) levels.[6] The G protein beta-gamma subunits can also directly activate G-protein-coupled inwardly rectifying potassium (GIRK) channels and inhibit N-type voltage-gated calcium channels.[5] **ML350**, as a competitive antagonist, binds to the KOR and prevents this signaling cascade from being initiated by an agonist.

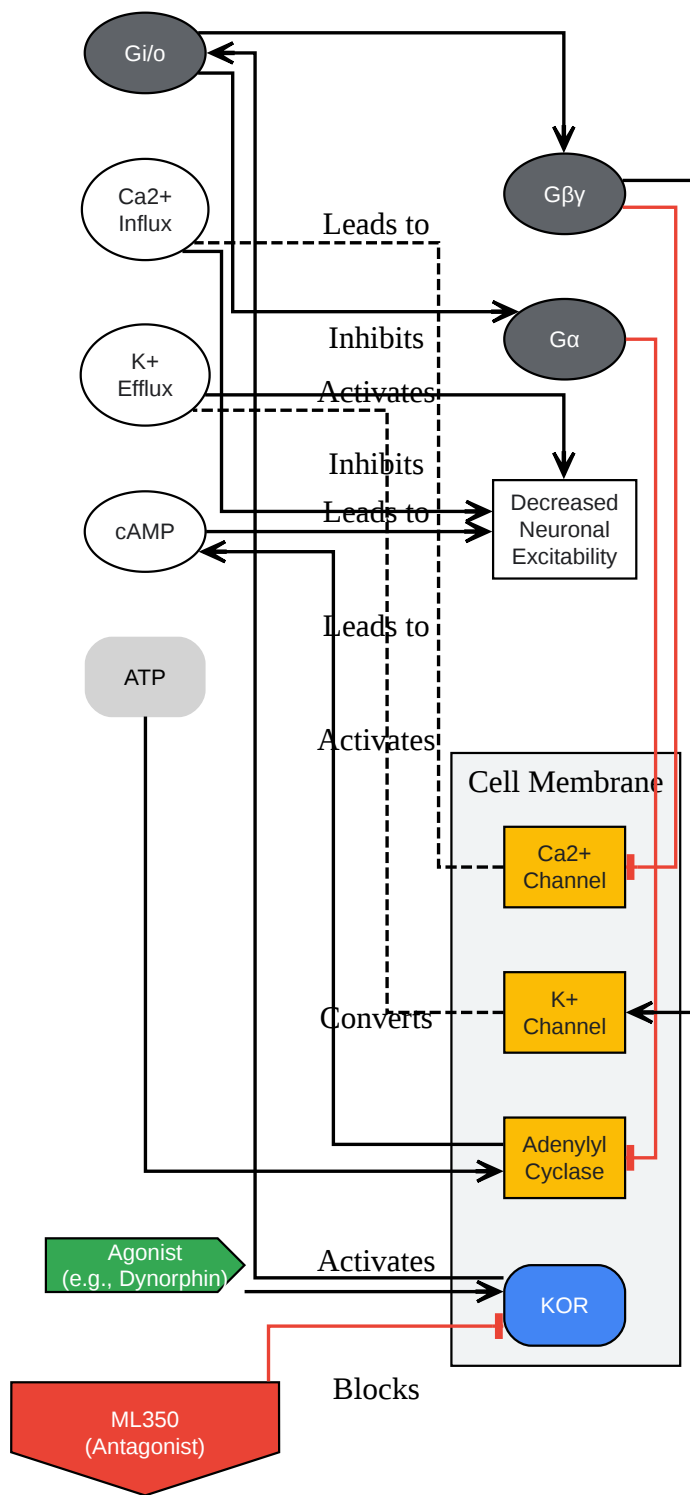

[Click to download full resolution via product page](#)

Kappa Opioid Receptor (KOR) signaling pathway and the inhibitory action of **ML350**.

Experimental Protocols

To determine the optimal concentration of **ML350** for your specific experimental setup, it is crucial to perform a dose-response curve to ascertain its potency (IC₅₀) and a cytotoxicity assay to ensure the chosen concentration is not toxic to the cells.

Experimental Workflow for Determining Optimal Concentration

The general workflow involves a series of steps starting from cell preparation to data analysis to identify a concentration that is both effective and non-toxic.

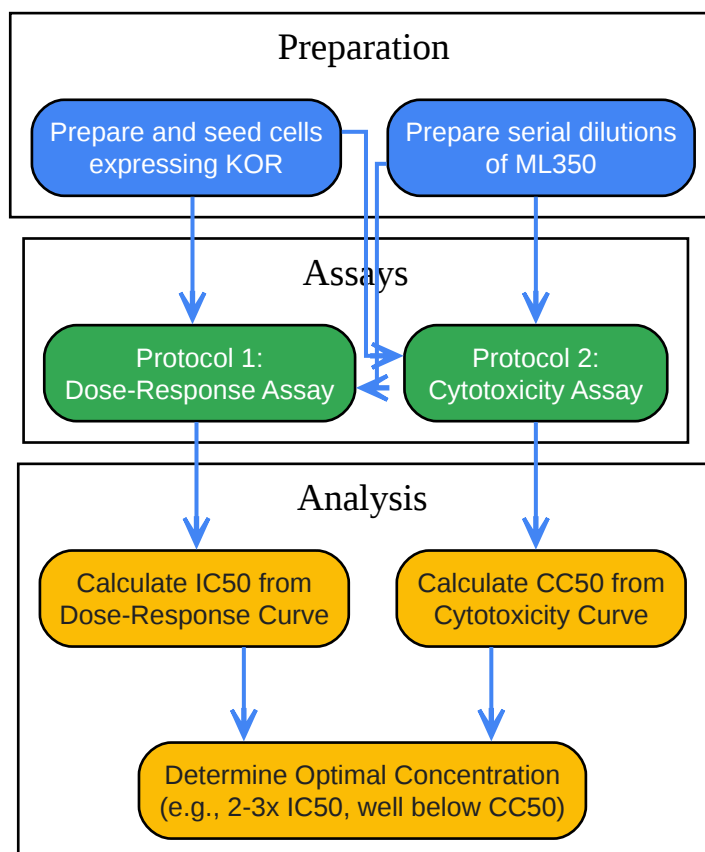

[Click to download full resolution via product page](#)

General workflow for optimizing **ML350** concentration.

Protocol 1: Dose-Response Assay to Determine IC₅₀

Objective: To determine the concentration of **ML350** that causes 50% inhibition of the KOR-mediated response to an agonist.

Materials:

- Cells expressing the Kappa Opioid Receptor
- **ML350** stock solution (e.g., 10 mM in DMSO)
- KOR agonist (e.g., U-50,488)
- Assay buffer or cell culture medium
- 96-well microplates
- Detection reagents for the specific assay readout (e.g., cAMP assay kit)
- Multichannel pipette
- Plate reader

Procedure:

- Cell Seeding: Seed cells in a 96-well plate at a density appropriate for your cell line and allow them to attach overnight.
- **ML350** Preparation: Prepare a series of dilutions of **ML350** in assay buffer or medium. A common approach is to use a 10-point, 1:3 serial dilution, with the highest concentration being at least 100-fold higher than the expected IC₅₀ (e.g., starting at 10 μM). Include a vehicle control (DMSO) and a no-agonist control.
- Antagonist Incubation: Remove the culture medium from the cells and add the **ML350** dilutions. Incubate for a predetermined time (e.g., 20-30 minutes) at 37°C.
- Agonist Stimulation: Add the KOR agonist at a concentration that elicits a submaximal response (EC₈₀ is commonly used). This allows for the inhibitory effect of the antagonist to be clearly observed.

- Incubation: Incubate for a time sufficient for the agonist to produce a measurable effect (e.g., 15-30 minutes).
- Detection: Lyse the cells (if required by the assay) and add the detection reagents according to the manufacturer's protocol (e.g., for a cAMP assay).
- Data Acquisition: Read the plate using a plate reader at the appropriate wavelength.
- Data Analysis:
 - Normalize the data to the vehicle control (0% inhibition) and the no-agonist control (100% inhibition).
 - Plot the percent inhibition against the log concentration of **ML350**.
 - Fit the data to a four-parameter logistic equation to determine the IC50 value.

Protocol 2: Cytotoxicity Assay

Objective: To determine the concentration of **ML350** that is toxic to the cells and to establish a therapeutic window.

Materials:

- Cells used in the primary assay
- **ML350** stock solution
- Cell culture medium
- 96-well clear-bottom microplates
- Cell viability reagent (e.g., MTT, MTS, or CellTiter-Glo)^{[7][8][9][10][11]}
- Multichannel pipette
- Plate reader (absorbance or luminescence)

Procedure:

- Cell Seeding: Seed cells in a 96-well plate and allow them to attach overnight.
- Compound Treatment: Prepare serial dilutions of **ML350** in culture medium at concentrations ranging from your intended experimental concentrations to several-fold higher. Add the dilutions to the cells.
- Incubation: Incubate the cells for a period relevant to your planned experiments (e.g., 24, 48, or 72 hours) at 37°C in a 5% CO2 incubator.
- Viability Measurement: Add the chosen cell viability reagent to each well according to the manufacturer's instructions.^{[7][8][9][10][11]}
- Data Acquisition: Measure the absorbance or luminescence using a plate reader.
- Data Analysis:
 - Normalize the data to the vehicle control (100% viability).
 - Plot the percent viability against the log concentration of **ML350**.
 - Determine the CC50 (half-maximal cytotoxic concentration) from the curve.

Determining the Optimal Concentration

The optimal concentration of **ML350** for your experiments should be:

- Effective: Typically, a concentration of 2-3 times the determined IC50 is a good starting point to ensure complete antagonism of the receptor.^[12]
- Non-toxic: The chosen concentration should be significantly lower than the CC50 value (ideally, at least 10-fold lower) to avoid off-target effects due to cytotoxicity.

By following these protocols, researchers can confidently determine an optimal, empirically validated concentration of **ML350** for their specific experimental needs.

Need Custom Synthesis?

BenchChem offers custom synthesis for rare earth carbides and specific isotopic labeling.

Email: info@benchchem.com or [Request Quote Online](#).

References

- [1. What are \$\kappa\$ opioid receptor antagonists and how do they work? \[synapse.patsnap.com\]](#)
- [2. \$\kappa\$ -opioid receptor - Wikipedia \[en.wikipedia.org\]](#)
- [3. reddit.com \[reddit.com\]](#)
- [4. Kappa Opioid Receptor Activation Decreases Inhibitory Transmission and Antagonizes Alcohol Effects in Rat Central Amygdala - PMC \[pmc.ncbi.nlm.nih.gov\]](#)
- [5. Physiology, Opioid Receptor - StatPearls - NCBI Bookshelf \[ncbi.nlm.nih.gov\]](#)
- [6. Frontiers | Pharmacology of Kappa Opioid Receptors: Novel Assays and Ligands \[frontiersin.org\]](#)
- [7. broadpharm.com \[broadpharm.com\]](#)
- [8. Cell Viability Assays - Assay Guidance Manual - NCBI Bookshelf \[ncbi.nlm.nih.gov\]](#)
- [9. researchgate.net \[researchgate.net\]](#)
- [10. benchchem.com \[benchchem.com\]](#)
- [11. Cell Viability Assay Protocols | Thermo Fisher Scientific - US \[thermofisher.com\]](#)
- [12. researchgate.net \[researchgate.net\]](#)
- To cite this document: BenchChem. [Determining the Optimal Concentration of ML350: Application Notes and Protocols]. BenchChem, [2026]. [Online PDF]. Available at: [<https://www.benchchem.com/product/b10763790/docs#determining-the-optimal-concentration-of-ml350-application-notes-and-protocols>]

Disclaimer & Data Validity:

The information provided in this document is for Research Use Only (RUO) and is strictly not intended for diagnostic or therapeutic procedures. While BenchChem strives to provide accurate protocols, we make no warranties, express or implied, regarding the fitness of this product for every specific experimental setup.

Technical Support: The protocols provided are for reference purposes. Unsure if this reagent suits your experiment?

Need Industrial/Bulk Grade? [Request Custom Synthesis Quote](#)

BenchChem

Our mission is to be the trusted global source of essential and advanced chemicals, empowering scientists and researchers to drive progress in science and industry.

Contact

Address: 3281 E Guasti Rd

Ontario, CA 91761, United States

Phone: (601) 213-4426

Email: info@benchchem.com

[Contact our Ph.D. Support Team for a compatibility check](#)