

Application Notes and Protocols: NCS-382 as a Tool to Study GHB Overdose

Author: BenchChem Technical Support Team. **Date:** April 2026

Compound of Interest

Compound Name: NCS-382
CAS No.: 326809-98-7
Cat. No.: B10763217

[Get Quote](#)

For Researchers, Scientists, and Drug Development Professionals

Introduction

Gamma-hydroxybutyrate (GHB) is an endogenous neurotransmitter and a drug of abuse known for its potent sedative effects, which can lead to life-threatening respiratory depression in overdose situations. The complex pharmacology of GHB, involving both specific GHB receptors and GABA(B) receptors, presents challenges for the development of effective overdose treatments.[1][2] **NCS-382** (6,7,8,9-tetrahydro-5-hydroxy-5H-benzo[a][3]annulen-6-ylidene)acetic acid) is a structural analog of GHB and the most well-characterized ligand for the GHB receptor.[1][4] While initially reported as a selective antagonist at the GHB receptor, subsequent research has revealed a more complex pharmacological profile.[5][6] Multiple studies have shown that **NCS-382** fails to antagonize many of the behavioral effects of GHB, and in some cases, may produce similar or even potentiate certain actions.[5][7] The antagonistic effects observed are sometimes attributed to an indirect action at GABA(B) receptors, particularly when these receptors are blocked.[5][6]

Despite the debate surrounding its antagonist properties, **NCS-382** remains a valuable research tool for elucidating the role of the GHB binding site in the context of GHB's overall effects, including overdose.[8] It is particularly useful in in vitro binding assays to characterize the GHB receptor and in in vivo studies to probe the contribution of this receptor to the toxicological effects of GHB.[8][9] These application notes provide detailed protocols for utilizing **NCS-382** as a research tool to investigate the mechanisms of GHB overdose.

Mechanism of Action

GHB's effects are primarily mediated through two receptor systems:

- **GHB Receptor:** A high-affinity receptor for which **NCS-382** is a potent ligand.[8] The physiological functions of this receptor are still under investigation but are thought to be distinct from the sedative effects of high-dose GHB.[10]
- **GABA(B) Receptor:** At higher, intoxicating doses, GHB acts as a weak partial agonist at GABA(B) receptors, which is believed to mediate its profound sedative and respiratory depressant effects.[10][11]

NCS-382 exhibits a high affinity for the GHB receptor but lacks significant affinity for GABA(A) or GABA(B) receptors.[6] Its utility in overdose research lies in its ability to selectively block the GHB receptor, allowing for the isolation and study of GABA(B) receptor-mediated effects of GHB.

Data Presentation

Quantitative Data for NCS-382

Parameter	Value	Species	Assay Conditions	Reference
Metabolism				
Dehydrogenation Km	29.5 ± 10.0 μmol/L	Mouse	Liver Microsomes	[12]
Dehydrogenation Km	12.7 ± 4.8 μmol/L	Human	Liver Microsomes	[12]
Glucuronidation Km	>100 μmol/L	Mouse & Human	Liver Microsomes	[12]
Permeability				
Apical to Basolateral	7.6 ± 1.7 x 10 ⁻⁶ cm/s	Canine	MDCK Cells (25 μM NCS-382)	[9]
Apical to Basolateral	1.4 ± 0.2 x 10 ⁻⁶ cm/s	Canine	MDCK Cells (50 μM NCS-382)	[9]
Apical to Basolateral	1.9 ± 0.2 x 10 ⁻⁶ cm/s	Canine	MDCK Cells (100 μM NCS-382)	[9]
Binding Affinity				
R-NCS-382 vs. RS-NCS-382	~2x more potent	Rat	[3H]NCS-382 displacement	[8]
R-NCS-382 vs. S-NCS-382	~14x more potent	Rat	[3H]NCS-382 displacement	[8]
R-NCS-382 vs. RS-NCS-382	~2x more potent	Rat	[3H]GHB displacement	[8]
R-NCS-382 vs. S-NCS-382	~60x more potent	Rat	[3H]GHB displacement	[8]

Signaling Pathways and Experimental Workflow

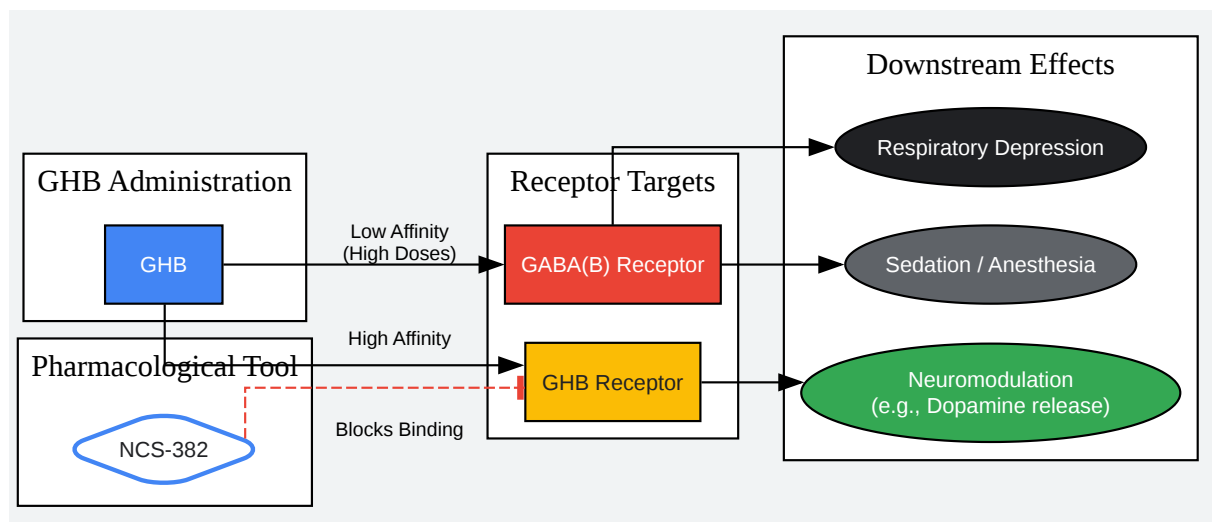

[Click to download full resolution via product page](#)

GHB Signaling and **NCS-382** Interaction

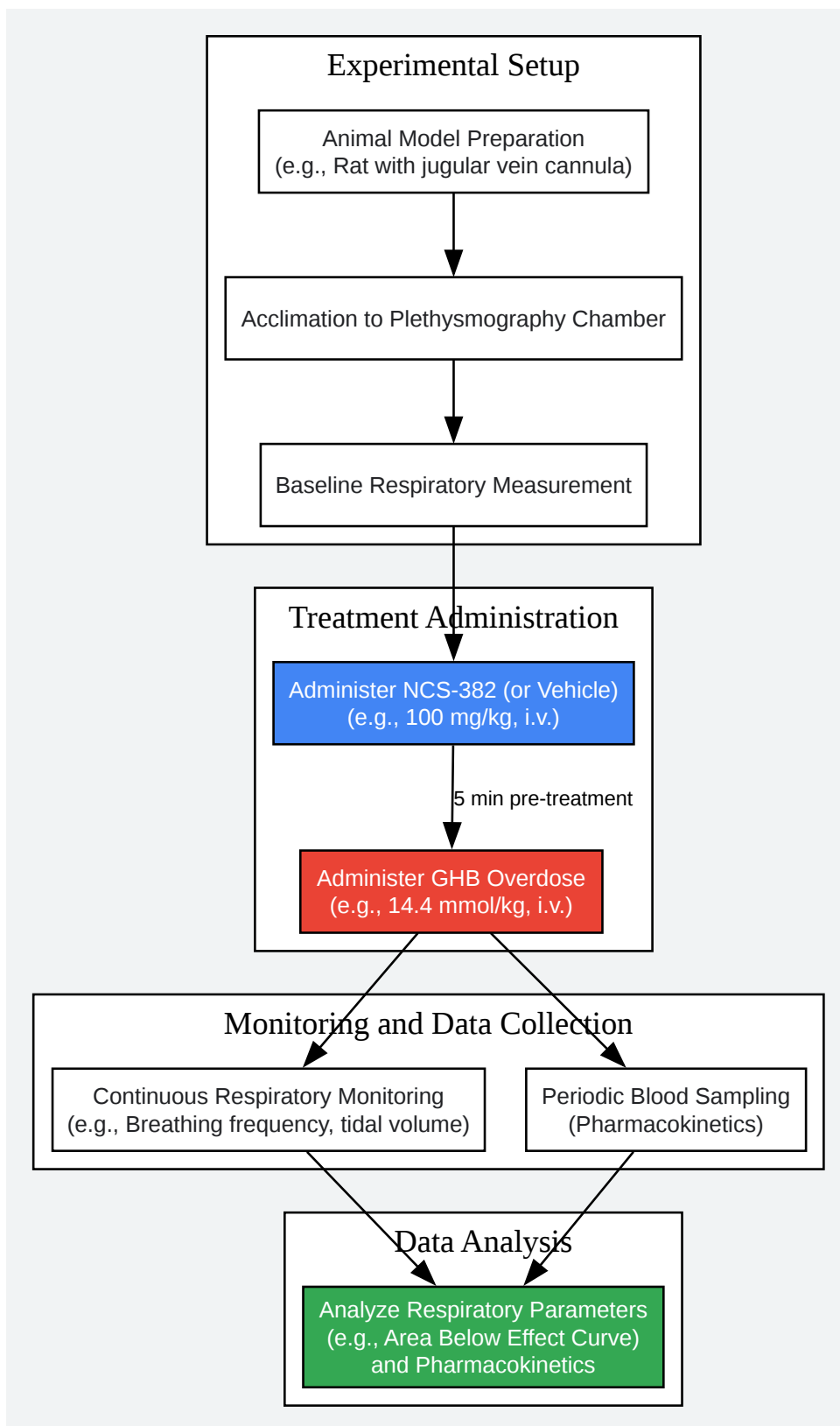

[Click to download full resolution via product page](#)

In Vivo GHB Overdose Study Workflow

Experimental Protocols

Protocol 1: In Vivo Assessment of NCS-382 on GHB-Induced Respiratory Depression in a Rat Model

This protocol is adapted from studies investigating the effects of GHB on respiratory function and the potential modulatory role of receptor antagonists.[\[1\]](#)[\[3\]](#)[\[11\]](#)[\[13\]](#)[\[14\]](#)

1. Objective: To determine if pretreatment with **NCS-382** alters the respiratory depressant effects of a GHB overdose in a rat model.

2. Materials:

- Male Sprague-Dawley rats (250-300g) with surgically implanted jugular vein cannulas.
- Sodium GHB (National Institute on Drug Abuse or equivalent).
- **NCS-382** (Tocris or equivalent).
- Sterile 0.9% saline.
- Whole-body plethysmography system (Buxco or equivalent).
- Syringes and infusion pumps.

3. Solutions Preparation:

- GHB Solution (300 mg/mL): Dissolve sodium GHB in sterile water or saline to a final concentration of 300 mg/mL.
- **NCS-382** Solution (100 mg/mL): Dissolve **NCS-382** in sterile 0.9% saline. Gentle warming and vortexing may be required. Prepare fresh on the day of the experiment.[\[1\]](#)

4. Experimental Procedure:

- Animal Acclimation: Place rats individually in the plethysmography chambers and allow them to acclimate for at least 45-60 minutes.[\[3\]](#)

- **Baseline Measurement:** Record baseline respiratory parameters (e.g., breathing frequency, tidal volume, minute volume) for 15 minutes.[3]
- **Pretreatment:** Administer **NCS-382** (100 mg/kg) or vehicle (saline) intravenously via the jugular cannula 5 minutes prior to GHB administration.[1]
- **GHB Administration:** Administer a high dose of GHB (e.g., 14.4 mmol/kg, which is approximately 1500 mg/kg) as an intravenous bolus.[1]
- **Respiratory Monitoring:** Continuously monitor and record respiratory parameters for at least 6 hours post-GHB administration.[3]
- **Data Analysis:** Calculate the change in respiratory parameters from baseline over time. Key metrics can include the maximum effect (E_{max}), the duration of the effect (T_d), and the area below the effect curve (ABEC). Compare these parameters between the **NCS-382** and vehicle-treated groups using appropriate statistical tests (e.g., t-test or ANOVA).

Protocol 2: Radioligand Binding Assay for GHB Receptor Using [3H]NCS-382

This protocol is a representative method based on standard radioligand binding techniques and information from studies using [3H]NCS-382.[8][15][16]

1. **Objective:** To determine the binding affinity (K_i) of a test compound for the GHB receptor using [3H]NCS-382 as the radioligand.
2. **Materials:**
 - Rat brain tissue (cortex and hippocampus are rich in GHB receptors).
 - [3H]NCS-382 (specific activity ~20-60 Ci/mmol).
 - Unlabeled GHB (for determining non-specific binding).
 - Test compounds.
 - Binding buffer (e.g., 50 mM Tris-HCl, pH 7.4).

- Polyethyleneimine (PEI) solution (0.5%).
- Glass fiber filters (e.g., Whatman GF/B).
- Scintillation fluid and liquid scintillation counter.
- Homogenizer and centrifuge.

3. Procedure:

- Membrane Preparation:
 - Homogenize fresh or frozen rat brain tissue in ice-cold binding buffer.
 - Centrifuge the homogenate at 1,000 x g for 10 minutes at 4°C to remove nuclei and large debris.
 - Centrifuge the resulting supernatant at 40,000 x g for 20 minutes at 4°C.
 - Resuspend the pellet in fresh binding buffer and repeat the centrifugation step.
 - Resuspend the final pellet in binding buffer and determine the protein concentration (e.g., using a Bradford assay).
- Binding Assay:
 - Pre-treat glass fiber filters by soaking in 0.5% PEI for at least 1 hour to reduce non-specific binding.
 - In assay tubes, add in the following order:
 - Binding buffer.
 - Test compound at various concentrations (or unlabeled GHB at 100 μM for non-specific binding, or buffer for total binding).
 - [³H]NCS-382 at a final concentration near its K_d (e.g., 10-20 nM).
 - Brain membrane preparation (50-100 μg of protein).

- Incubate the tubes at 4°C for 60 minutes.
- Assay Termination and Counting:
 - Rapidly filter the contents of each tube through the pre-soaked glass fiber filters using a cell harvester.
 - Wash the filters three times with ice-cold binding buffer.
 - Place the filters in scintillation vials, add scintillation fluid, and allow to sit for several hours.
 - Measure the radioactivity in a liquid scintillation counter.
- Data Analysis:
 - Calculate specific binding by subtracting non-specific binding (counts in the presence of excess unlabeled GHB) from total binding.
 - Plot the percentage of specific binding against the log concentration of the test compound to generate a competition curve.
 - Determine the IC₅₀ (concentration of test compound that inhibits 50% of specific binding) from the curve.
 - Calculate the K_i value using the Cheng-Prusoff equation: $K_i = IC_{50} / (1 + [L]/K_d)$, where [L] is the concentration of [³H]**NCS-382** and K_d is its dissociation constant for the receptor.

Conclusion

NCS-382 is a critical pharmacological tool for investigating the specific role of the GHB receptor in the complex cascade of events following GHB administration, including overdose. While not a simple antagonist, its ability to selectively bind to the GHB receptor allows researchers to dissect the distinct contributions of the GHB and GABA(B) receptor systems to GHB's physiological and toxicological effects. The protocols provided herein offer a framework for utilizing **NCS-382** in both in vivo and in vitro models to advance our understanding of GHB overdose and to explore novel therapeutic strategies. Researchers should remain mindful of the nuanced pharmacology of **NCS-382** when interpreting experimental results.

Need Custom Synthesis?

BenchChem offers custom synthesis for rare earth carbides and specific isotopic labeling.

Email: info@benchchem.com or [Request Quote Online](#).

References

- 1. Treatment of γ -Hydroxybutyrate Overdose with the GABAB Antagonist SGS742 - PMC [[pmc.ncbi.nlm.nih.gov](https://pubmed.ncbi.nlm.nih.gov/)]
- 2. [researchgate.net](https://www.researchgate.net/) [[researchgate.net](https://www.researchgate.net/)]
- 3. Effect of Chronic γ -hydroxybutyrate (GHB) Administration on GHB- Induced Respiratory Depression - PMC [[pmc.ncbi.nlm.nih.gov](https://pubmed.ncbi.nlm.nih.gov/)]
- 4. In vitro toxicological evaluation of NCS-382, a high-affinity antagonist of γ -hydroxybutyrate (GHB) binding - PubMed [pubmed.ncbi.nlm.nih.gov]
- 5. A review of pharmacology of NCS-382, a putative antagonist of gamma-hydroxybutyric acid (GHB) receptor - PubMed [pubmed.ncbi.nlm.nih.gov]
- 6. A Review of Pharmacology of NCS-382, a Putative Antagonist of γ -Hydroxybutyric Acid (GHB) Receptor - PMC [[pmc.ncbi.nlm.nih.gov](https://pubmed.ncbi.nlm.nih.gov/)]
- 7. Effects of the putative antagonist NCS382 on the behavioral pharmacological actions of gammahydroxybutyrate in mice - PubMed [pubmed.ncbi.nlm.nih.gov]
- 8. [researchgate.net](https://www.researchgate.net/) [[researchgate.net](https://www.researchgate.net/)]
- 9. Toxicologic/Transport Properties of NCS-382, a γ -Hydroxybutyrate (GHB) Receptor Ligand, in Neuronal and Epithelial Cells: Therapeutic Implications for SSADH Deficiency, a GABA Metabolic Disorder - PMC [[pmc.ncbi.nlm.nih.gov](https://pubmed.ncbi.nlm.nih.gov/)]
- 10. Concentration-Effect Relationships for the Drug of Abuse γ -Hydroxybutyric Acid - PMC [[pmc.ncbi.nlm.nih.gov](https://pubmed.ncbi.nlm.nih.gov/)]
- 11. γ -Hydroxybutyrate (GHB)-induced respiratory depression: combined receptor-transporter inhibition therapy for treatment in GHB overdose - PubMed [pubmed.ncbi.nlm.nih.gov]
- 12. Research Portal [rex.libraries.wsu.edu]
- 13. γ -Hydroxybutyrate (GHB)-Induced Respiratory Depression: Combined Receptor-Transporter Inhibition Therapy for Treatment in GHB Overdose - PMC [[pmc.ncbi.nlm.nih.gov](https://pubmed.ncbi.nlm.nih.gov/)]
- 14. Effect of chronic γ -hydroxybutyrate (GHB) administration on GHB toxicokinetics and GHB-induced respiratory depression - PubMed [pubmed.ncbi.nlm.nih.gov]

- 15. Saturation assays of radioligand binding to receptors and their allosteric modulatory sites - PubMed [pubmed.ncbi.nlm.nih.gov]
- 16. Ethanol does not alter the binding of the gamma-hydroxybutyric acid (GHB) receptor ligand [3H]NCS-382 in the rat brain - PubMed [pubmed.ncbi.nlm.nih.gov]
- To cite this document: BenchChem. [Application Notes and Protocols: NCS-382 as a Tool to Study GHB Overdose]. BenchChem, [2026]. [Online PDF]. Available at: [https://www.benchchem.com/product/b10763217/docs#application-notes-and-protocols-ncs-382-as-a-tool-to-study-ghb-overdose]

Disclaimer & Data Validity:

The information provided in this document is for Research Use Only (RUO) and is strictly not intended for diagnostic or therapeutic procedures. While BenchChem strives to provide accurate protocols, we make no warranties, express or implied, regarding the fitness of this product for every specific experimental setup.

Technical Support: The protocols provided are for reference purposes. Unsure if this reagent suits your experiment?

Need Industrial/Bulk Grade? [Request Custom Synthesis Quote](#)

BenchChem

Our mission is to be the trusted global source of essential and advanced chemicals, empowering scientists and researchers to drive progress in science and industry.

Contact

Address: 3281 E Guasti Rd
Ontario, CA 91761, United States
Phone: (601) 213-4426
Email: info@benchchem.com

[Contact our Ph.D. Support Team for a compatibility check](#)

