

Enhancing Homology-Directed Repair in Genome Editing: Application Notes for SCR7 Pyrazine

Author: BenchChem Technical Support Team. **Date:** April 2026

Compound of Interest

Compound Name: SCR7
Cat. No.: B10762385

[Get Quote](#)

For Researchers, Scientists, and Drug Development Professionals

Abstract

Precision genome editing using technologies like CRISPR-Cas9 relies on the cellular DNA repair machinery. Homology-Directed Repair (HDR) is a high-fidelity pathway that enables precise insertions, deletions, or substitutions, but it is often outcompeted by the more efficient but error-prone Non-Homologous End Joining (NHEJ) pathway. This application note details the use of **SCR7** pyrazine, a small molecule inhibitor of DNA Ligase IV, to enhance the efficiency of HDR. By temporarily suppressing NHEJ, **SCR7** pyrazine shifts the balance of DNA repair towards the desired HDR pathway, thereby increasing the frequency of precise genomic modifications. This document provides an overview of the mechanism, experimental protocols, and relevant data for the application of **SCR7** pyrazine in genome editing workflows.

Introduction to SCR7 Pyrazine

SCR7 pyrazine is a derivative of **SCR7**, which has been identified as an inhibitor of DNA Ligase IV, a key enzyme in the NHEJ pathway.[1][2] By inhibiting DNA Ligase IV, **SCR7** pyrazine

blocks the final ligation step of NHEJ, leading to an accumulation of unrepaired double-strand breaks (DSBs) that are then preferentially repaired by the HDR pathway when a donor template is provided.[3][4] This targeted inhibition makes **SCR7** pyrazine a valuable tool for increasing the efficiency of CRISPR-Cas9-mediated HDR in various cell types and organisms. [5]

Mechanism of Action

The choice between the two major DNA double-strand break repair pathways, NHEJ and HDR, is a critical determinant for the outcome of genome editing experiments.

- **Non-Homologous End Joining (NHEJ):** This is the predominant repair pathway in most mammalian cells. It is active throughout the cell cycle and quickly ligates broken DNA ends. However, this process is prone to introducing small insertions or deletions (indels), which can lead to gene knockouts. The final step of this pathway is catalyzed by DNA Ligase IV.
- **Homology-Directed Repair (HDR):** This is a more precise repair mechanism that uses a homologous DNA template to repair the break. It is primarily active in the S and G2 phases of the cell cycle. For genome editing, an exogenous donor template with desired genetic modifications can be supplied to be incorporated at the target site.

SCR7 pyrazine functions by binding to the DNA binding domain of DNA Ligase IV, thereby preventing it from ligating the broken DNA ends. This inhibition of NHEJ creates a larger window of opportunity for the HDR pathway to utilize the provided donor template for repair, resulting in a higher frequency of precise editing events.

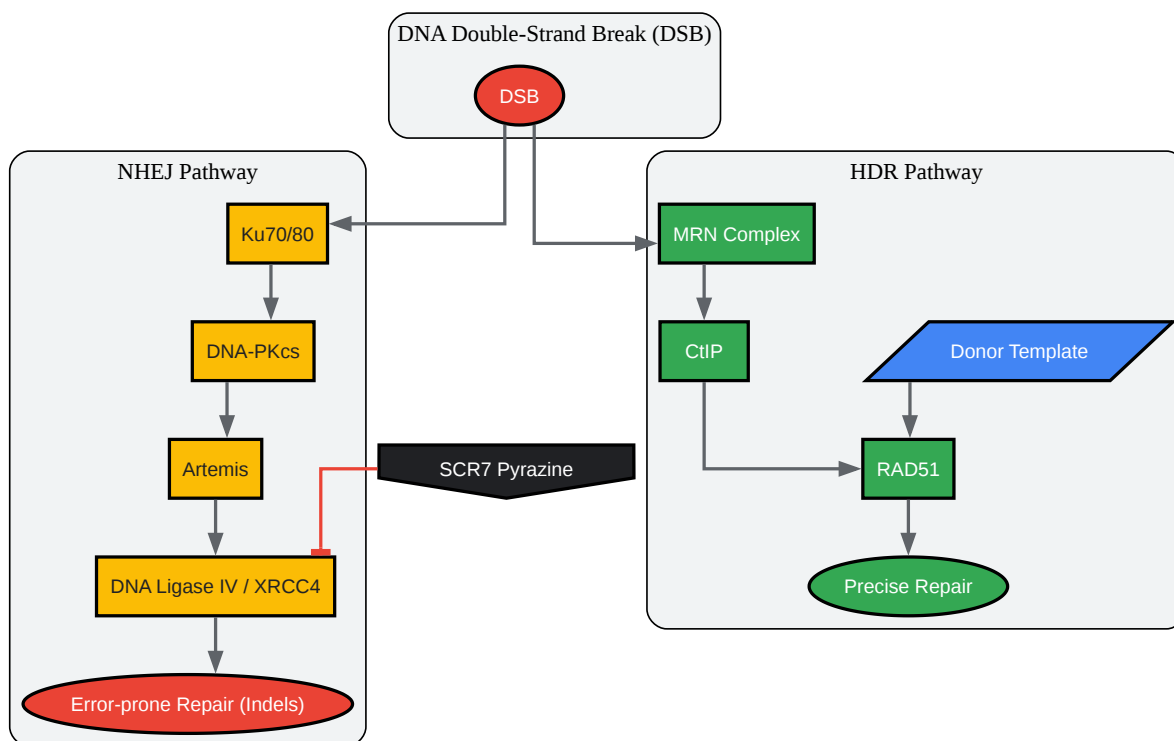

[Click to download full resolution via product page](#)

Figure 1: Simplified signaling pathway of DNA DSB repair and the inhibitory action of **SCR7** Pyrazine on the NHEJ pathway.

Quantitative Data Summary

The effectiveness of **SCR7** pyrazine in enhancing HDR efficiency varies depending on the cell type, experimental conditions, and the specific genomic locus. The following tables summarize quantitative data from various studies.

Cell Line	Fold Increase in HDR Efficiency	SCR7/SCR7 Pyrazine Concentration	Reference
MeiJuSo	Up to 19-fold	1 μ M	
HEK293T	2-fold	Not Specified	
A549	3-fold	0.01 μ M	
HEK293	5-fold	Not Specified	
Murine DC2.4	~13-fold	1 μ M	
MCF7	50% increase in genetic editing	Not Specified	
Xenopus oocytes	7.4-22% improvement	Not Specified	

Cell Line	IC50 Value (SCR7/SCR7 Pyrazine)	Reference
MCF7	40 μ M	
A549	34 μ M	
HeLa	44 μ M	
T47D	8.5 μ M	
A2780	120 μ M	
HT1080	10 μ M	
Nalm6	50 μ M	

Experimental Protocols

This section provides a general protocol for using **SCR7** pyrazine to enhance HDR efficiency in mammalian cells. Optimization of concentration and incubation time is recommended for each specific cell line and experimental setup.

Materials

- **SCR7** pyrazine (MedChemExpress, HY-12742 or similar)
- Dimethyl sulfoxide (DMSO) for stock solution preparation
- Cell culture medium appropriate for the cell line
- CRISPR-Cas9 components (e.g., plasmid, RNP)
- Donor template (plasmid or single-stranded oligodeoxynucleotide - ssODN)
- Transfection reagent

Protocol

- Cell Seeding: Plate cells at a density that will result in 50-70% confluency at the time of transfection.
- Transfection: Co-transfect the cells with the CRISPR-Cas9 components and the donor template using a suitable transfection method.
- **SCR7** Pyrazine Treatment:
 - Immediately following transfection, add **SCR7** pyrazine to the cell culture medium.
 - The final concentration typically ranges from 1 μM to 20 μM . A concentration of 1 μM has been shown to be effective in several studies.
 - A dose-response experiment is recommended to determine the optimal concentration for your cell line, balancing HDR enhancement with potential cytotoxicity.
- Incubation: Incubate the cells with **SCR7** pyrazine for 24 to 48 hours.
- Post-Treatment: After the incubation period, remove the medium containing **SCR7** pyrazine and replace it with fresh medium.
- Analysis: Culture the cells for an additional 48-72 hours to allow for expression of the edited gene. Analyze the HDR efficiency using appropriate methods such as flow cytometry (for

fluorescent reporters), PCR-based methods (e.g., RFLP, T7E1), or next-generation sequencing.

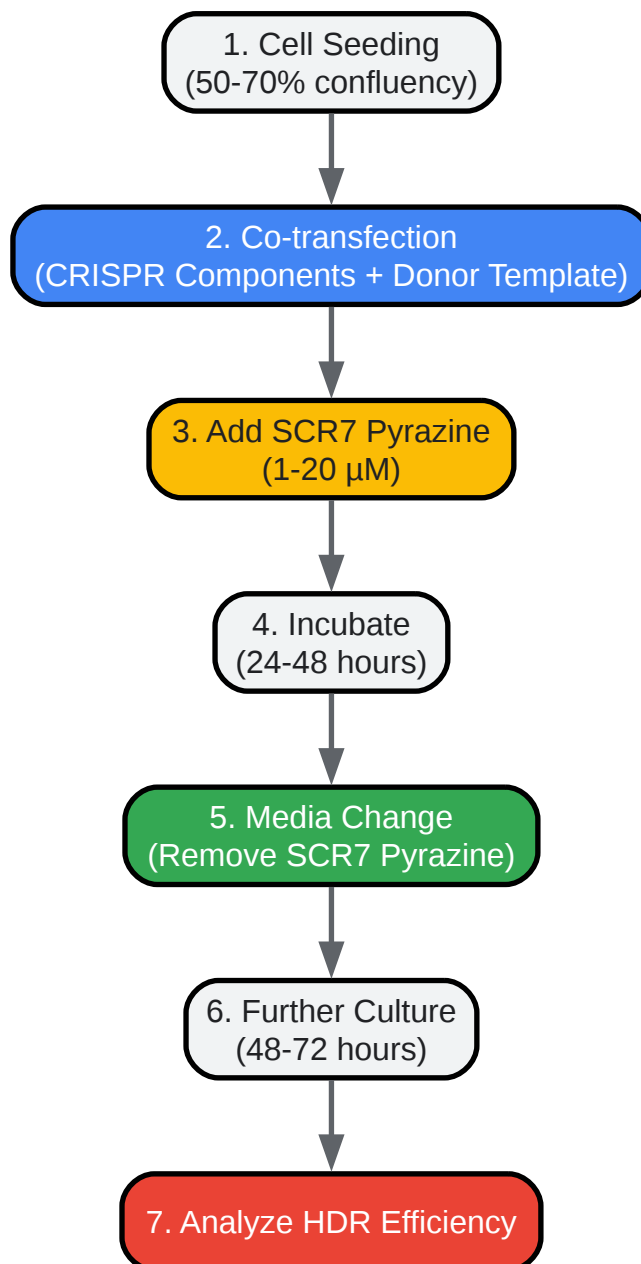

[Click to download full resolution via product page](#)

Figure 2: General experimental workflow for using **SCR7** Pyrazine to enhance HDR efficiency.

Considerations and Limitations

- **Cytotoxicity:** **SCR7** and its derivatives can exhibit cytotoxicity at higher concentrations. It is crucial to perform a dose-response curve to identify the optimal concentration that maximizes HDR enhancement while minimizing cell death.
- **Cell Line Variability:** The effectiveness of **SCR7** pyrazine can vary significantly between different cell lines, potentially due to varying expression levels of DNA Ligase IV.
- **Off-target Effects:** While **SCR7** pyrazine targets DNA Ligase IV, potential off-target effects should be considered, especially in the context of therapeutic applications.
- **Combination Therapies:** The co-administration of **SCR7** pyrazine with other molecules that enhance HDR, such as RAD51 agonists (e.g., RS-1), has been explored. Synergistic effects may be observed, but this requires further optimization.

Conclusion

SCR7 pyrazine is a valuable and accessible tool for researchers seeking to improve the efficiency of homology-directed repair in genome editing experiments. By inhibiting the competing NHEJ pathway, it effectively channels the repair of CRISPR-Cas9 induced double-strand breaks towards the high-fidelity HDR pathway. Careful optimization of experimental parameters, particularly concentration and incubation time, is essential to achieve the best results for a given cellular system. The protocols and data presented in this application note provide a solid foundation for the successful implementation of **SCR7** pyrazine in your genome editing workflows.

Need Custom Synthesis?

BenchChem offers custom synthesis for rare earth carbides and specific isotopic labeling.

Email: info@benchchem.com or [Request Quote Online](#).

References

- [1. medchemexpress.com](https://www.medchemexpress.com) [[medchemexpress.com](https://www.medchemexpress.com)]
- [2. medchemexpress.com](https://www.medchemexpress.com) [[medchemexpress.com](https://www.medchemexpress.com)]

- [3. Synergistic combination of RAD51-SCR7 improves CRISPR-Cas9 genome editing efficiency by preventing R-loop accumulation - PMC \[pmc.ncbi.nlm.nih.gov\]](#)
- [4. medkoo.com \[medkoo.com\]](#)
- [5. selleckchem.com \[selleckchem.com\]](#)
- To cite this document: BenchChem. [Enhancing Homology-Directed Repair in Genome Editing: Application Notes for SCR7 Pyrazine]. BenchChem, [2026]. [Online PDF]. Available at: [<https://www.benchchem.com/product/b10762385/docs#enhancing-homology-directed-repair-in-genome-editing-application-notes-for-scr7-pyrazine>]

Disclaimer & Data Validity:

The information provided in this document is for Research Use Only (RUO) and is strictly not intended for diagnostic or therapeutic procedures. While BenchChem strives to provide accurate protocols, we make no warranties, express or implied, regarding the fitness of this product for every specific experimental setup.

Technical Support: The protocols provided are for reference purposes. Unsure if this reagent suits your experiment?

Need Industrial/Bulk Grade? [Request Custom Synthesis Quote](#)

BenchChem

Our mission is to be the trusted global source of essential and advanced chemicals, empowering scientists and researchers to drive progress in science and industry.

Contact

Address: 3281 E Guasti Rd
Ontario, CA 91761, United States
Phone: (601) 213-4426
Email: info@benchchem.com

[Contact our Ph.D. Support Team for a compatibility check](#)

