

# Application of Erythromycin in Studies of Bacterial Protein Synthesis: A Technical Guide

**Author:** BenchChem Technical Support Team. **Date:** May 2026

## Compound of Interest

Compound Name: *Erythromycin*

CAS No.: 5442-22-8

Cat. No.: B10762701

[Get Quote](#)

For Researchers, Scientists, and Drug Development Professionals

## Authored by: Gemini, Senior Application Scientist Introduction: Unraveling Translational Control with a Classic Antibiotic

**Erythromycin**, a macrolide antibiotic, has been a cornerstone in treating bacterial infections for decades. Its clinical efficacy stems from its specific inhibition of bacterial protein synthesis.[1][2] Beyond its therapeutic applications, **erythromycin** has emerged as an indispensable tool for researchers dissecting the intricate mechanisms of translation. By binding to the 50S ribosomal subunit, **erythromycin** obstructs the nascent polypeptide exit tunnel (NPET), leading to a bacteriostatic effect.[3][4] This blockage is not a simple "plug-in-a-tunnel" mechanism; instead, it is highly context-dependent, relying on the sequence of the nascent polypeptide chain being synthesized.[5][6] This unique property makes **erythromycin** a powerful probe to investigate ribosomal dynamics, nascent peptide-tunnel interactions, and the regulation of gene expression through translational stalling.

This comprehensive guide provides detailed application notes and protocols for utilizing **erythromycin** in the study of bacterial protein synthesis. We will delve into the causality behind experimental choices, provide self-validating protocols, and ground our claims in authoritative scientific literature.

## The Molecular Mechanism of Erythromycin Action

**Erythromycin's** primary target is the 50S subunit of the bacterial ribosome, specifically binding to the 23S rRNA component near the peptidyl transferase center (PTC) at the entrance of the NPET.[3][4] This binding event physically constricts the tunnel, allowing for the synthesis of only a short oligopeptide, typically 6-8 amino acids long, before the elongating peptide collides with the antibiotic.[3] This steric hindrance inhibits the translocation step of protein synthesis, where the ribosome would typically move one codon down the mRNA.[3]

The interaction between **erythromycin**, the ribosome, and the nascent peptide is a dynamic interplay. The specific amino acid sequence of the nascent chain can influence the stalling efficiency, a phenomenon that has been exploited to understand how the ribosome "senses" the growing polypeptide.[5][6]

## Visualizing the Mechanism: Erythromycin's Interaction with the Ribosome

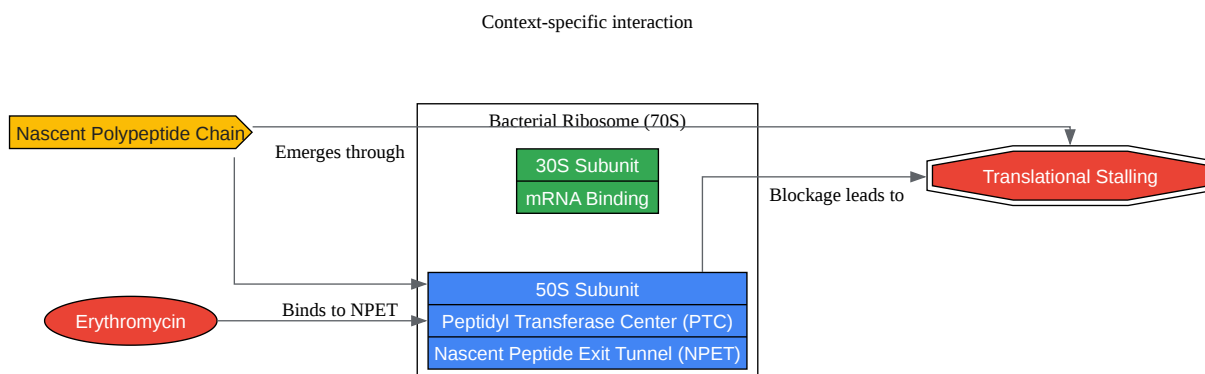

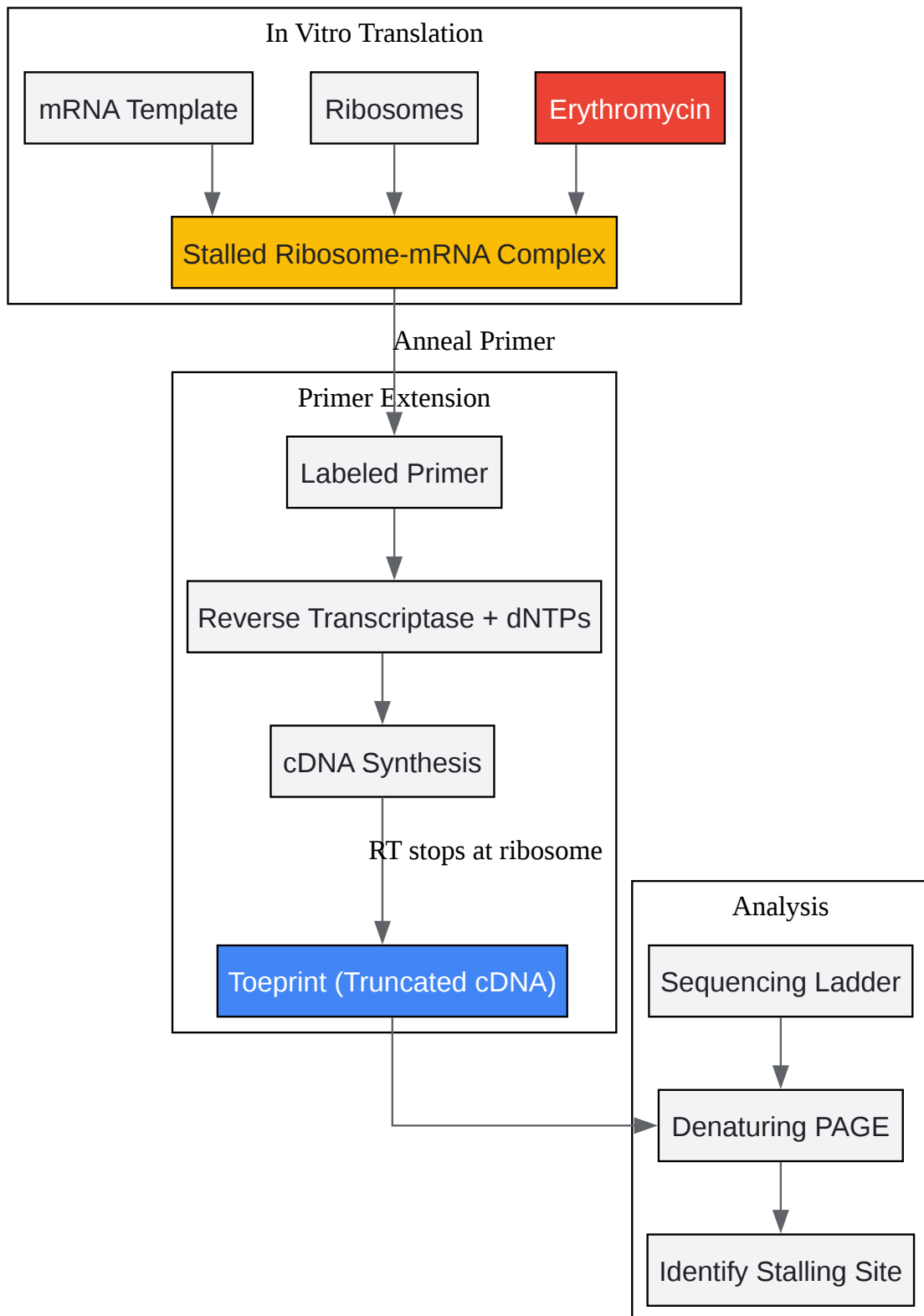

[Click to download full resolution via product page](#)

**Need Custom Synthesis?**

BenchChem offers custom synthesis for rare earth carbides and specific isotopic labeling.

Email: [info@benchchem.com](mailto:info@benchchem.com) or [Request Quote Online](#).

## Sources

- [1. Fluorescence Polarization Method To Characterize Macrolide-Ribosome Interactions - PMC \[pmc.ncbi.nlm.nih.gov\]](#)
- [2. Molecular basis for erythromycin-dependent ribosome-stalling during translation of the ErmBL leader peptide - PMC \[pmc.ncbi.nlm.nih.gov\]](#)
- [3. benchchem.com \[benchchem.com\]](#)
- [4. pdf.benchchem.com \[pdf.benchchem.com\]](#)
- [5. Direct Measurements of Erythromycin's Effect on Protein Synthesis Kinetics in Living Bacterial Cells - PubMed \[pubmed.ncbi.nlm.nih.gov\]](#)
- [6. Erythromycin leads to differential protein expression through differences in electrostatic and dispersion interactions with nascent proteins - PMC \[pmc.ncbi.nlm.nih.gov\]](#)
- [To cite this document: BenchChem. \[Application of Erythromycin in Studies of Bacterial Protein Synthesis: A Technical Guide\]. BenchChem, \[2026\]. \[Online PDF\]. Available at: \[https://www.benchchem.com/product/b10762701/docs#application-of-erythromycin-in-studies-of-bacterial-protein-synthesis-a-technical-guide\]](#)

---

### Disclaimer & Data Validity:

The information provided in this document is for Research Use Only (RUO) and is strictly not intended for diagnostic or therapeutic procedures. While BenchChem strives to provide accurate protocols, we make no warranties, express or implied, regarding the fitness of this product for every specific experimental setup.

**Technical Support:** The protocols provided are for reference purposes. Unsure if this reagent suits your experiment?

**Need Industrial/Bulk Grade?** [Request Custom Synthesis Quote](#)

# BenchChem

Our mission is to be the trusted global source of essential and advanced chemicals, empowering scientists and researchers to drive progress in science and industry.

## Contact

Address: 3281 E Guasti Rd  
Ontario, CA 91761, United States  
Phone: (601) 213-4426  
Email: [info@benchchem.com](mailto:info@benchchem.com)

[Contact our Ph.D. Support Team for a compatibility check](#)