

# A Comparative Guide to CEP-28122: A Selective ALK Inhibitor

**Author:** BenchChem Technical Support Team. **Date:** April 2026

## Compound of Interest

Compound Name: CEP-28122 mesylate salt

Cat. No.: B10762211

[Get Quote](#)

For Researchers, Scientists, and Drug Development Professionals

This guide provides an objective comparison of the preclinical performance of CEP-28122, a selective Anaplastic Lymphoma Kinase (ALK) inhibitor, with other prominent ALK inhibitors. The information presented is supported by experimental data to assist researchers in making informed decisions for their drug development and discovery programs.

## Introduction to ALK Inhibition

Anaplastic Lymphoma Kinase (ALK) is a receptor tyrosine kinase that plays a crucial role in the development of the nervous system.<sup>[1]</sup> Genetic alterations, such as chromosomal translocations, gene amplifications, and point mutations, can lead to constitutive activation of ALK, driving the growth and survival of various cancers, including non-small cell lung cancer (NSCLC), anaplastic large cell lymphoma (ALCL), and neuroblastoma.<sup>[2][3]</sup> This has established ALK as a key therapeutic target in oncology.<sup>[4]</sup> Small molecule ALK inhibitors have demonstrated significant clinical efficacy in patients with ALK-positive malignancies. This guide focuses on the preclinical profile of CEP-28122 in comparison to other well-established ALK inhibitors.

## Biochemical Potency and Selectivity

The efficacy of a kinase inhibitor is determined by its potency against the intended target and its selectivity over other kinases, which can help minimize off-target toxicities. The following tables summarize the in vitro inhibitory activities of CEP-28122 and a panel of comparator ALK inhibitors.

Table 1: In Vitro Potency Against Wild-Type ALK

Inhibitor	IC50 (nM) for ALK	Assay Type	Reference
CEP-28122	1.9	TRF Assay	[2]
Crizotinib	24	Cell-based assay	[5]
Alectinib	1.9	Cell-free assay	[6]
Brigatinib	0.6	In vitro kinase assay	[7]
Ceritinib	0.2	Cell-free assay	[8]
Lorlatinib	<0.07 (Ki)	Biochemical assay	[9]

Table 2: Kinase Selectivity Profile

This table presents the inhibitory activity of the compounds against a selection of off-target kinases. A higher IC50 value indicates lower potency and thus higher selectivity for ALK.

Inhibitor	Off-Target Kinase	IC50 (nM)	Fold Selectivity (Off-Target IC50 / ALK IC50)	Reference
CEP-28122	Flt4	46	24.2	[10]
CEP-28122	Rsk2	7-19	~3.7 - 10	[2]
Crizotinib	c-MET	~5	~0.2 (less selective)	[11]
Alectinib	RET	-	Highly Selective	[12]
Brigatinib	ROS1	1.9	~3.2	[13]
Brigatinib	FLT3	2.1	~3.5	[13]
Ceritinib	IGF-1R	8	40	[14]
Ceritinib	InsR	7	35	[14]
Lorlatinib	ROS1	<0.02 (Ki)	~0.28 (less selective)	[9]

Note: The selectivity data is compiled from various sources and assay conditions may differ.

## Cellular Activity

The ability of an inhibitor to suppress ALK activity within a cellular context is a critical measure of its potential therapeutic efficacy.

Table 3: Cellular ALK Phosphorylation Inhibition and Anti-proliferative Activity

Inhibitor	Cell Line	ALK Status	Cellular IC50 (nM) (pALK Inhibition)	Anti-proliferative IC50 (nM)	Reference
CEP-28122	Karpas-299	NPM-ALK	-	20	[6]
Crizotinib	H3122	EML4-ALK	165 - 3039 (mutants)	-	[15]
Alectinib	KARPAS-299	NPM-ALK	-	3	[6]
Brigatinib	H3122	EML4-ALK	14	14	[13]
Ceritinib	H3122	EML4-ALK	< Crizotinib	More potent than Crizotinib	[1]
Lorlatinib	BaF3	EML4-ALK	0.2 - 77 (mutants)	-	[9]

## Signaling Pathways and Experimental Workflows

To visualize the mechanism of action and the experimental approaches used to validate these inhibitors, the following diagrams are provided.

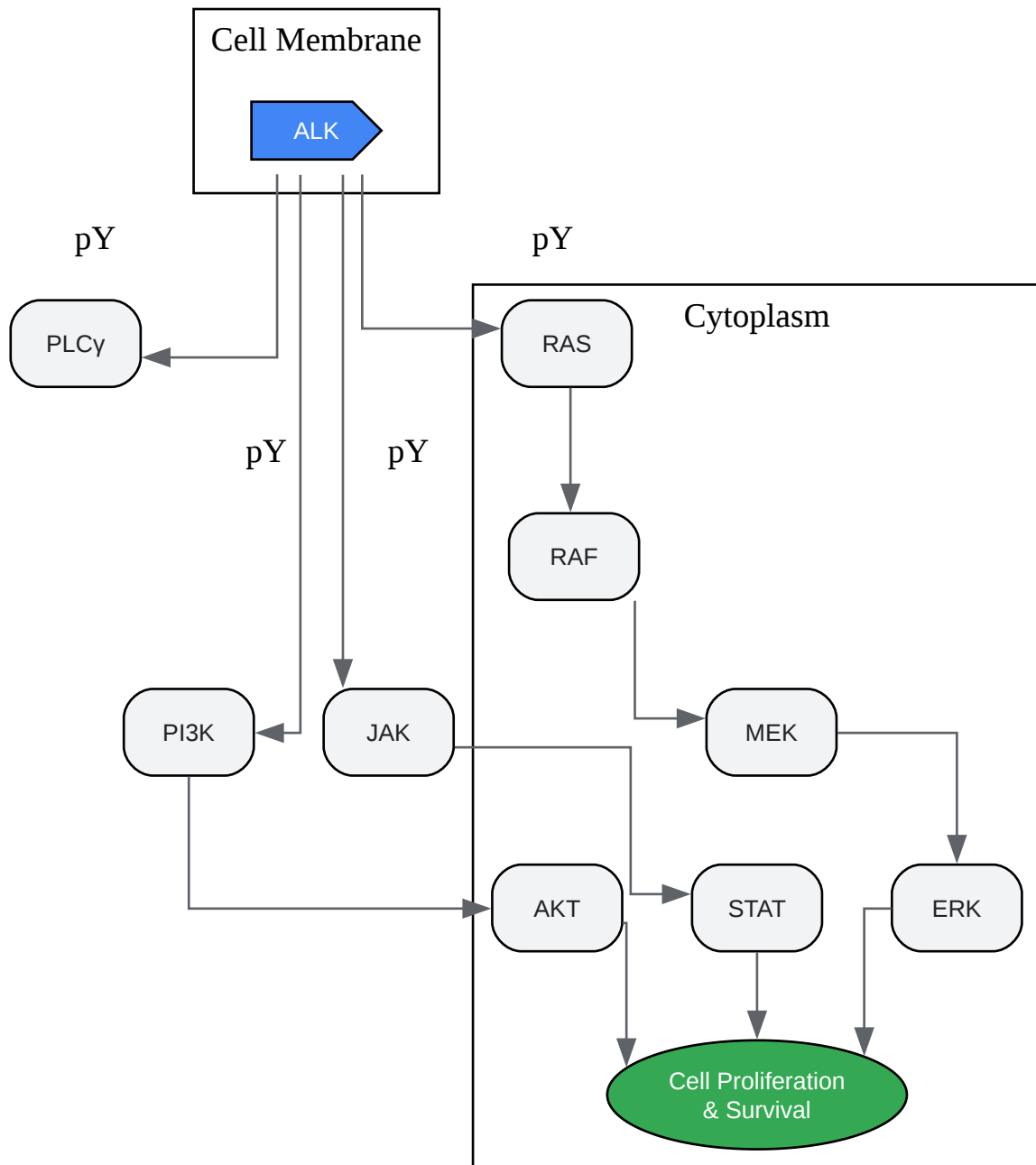

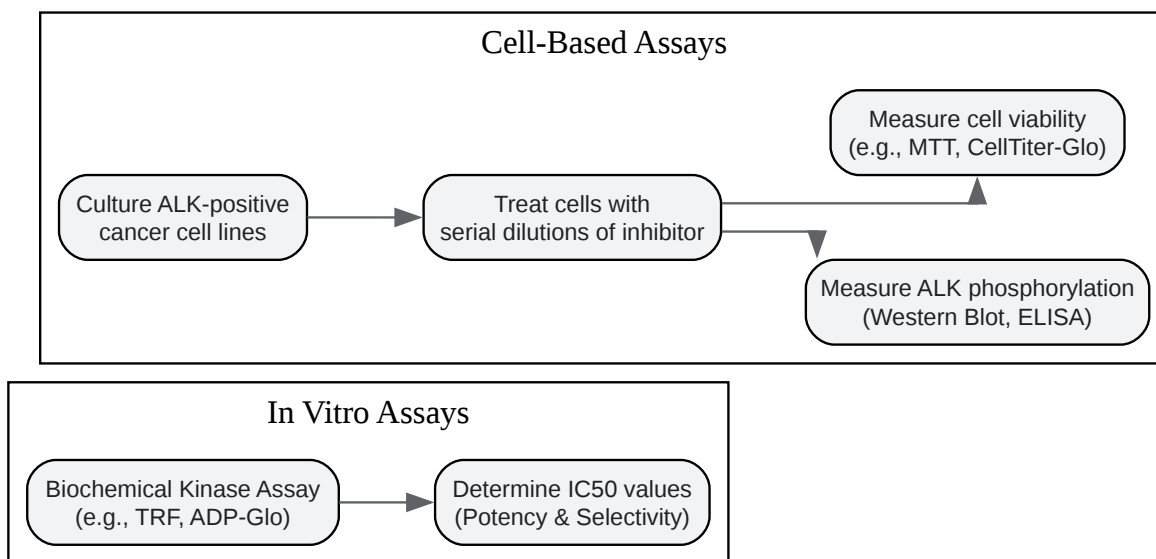

[Click to download full resolution via product page](#)

### Need Custom Synthesis?

BenchChem offers custom synthesis for rare earth carbides and specific isotopic labeling.

Email: [info@benchchem.com](mailto:info@benchchem.com) or [Request Quote Online](#).

## References

- [1. researchgate.net \[researchgate.net\]](https://www.researchgate.net)
- [2. ADP-Glo™ Kinase Assay Protocol \[promega.sg\]](https://www.promega.com)
- [3. documents.thermofisher.com \[documents.thermofisher.com\]](https://www.thermofisher.com)
- [4. documents.thermofisher.com \[documents.thermofisher.com\]](https://www.thermofisher.com)
- [5. Efficacy and safety of ceritinib in anaplastic lymphoma kinase-rearranged non-small cell lung cancer: A systematic review and meta-analysis - PMC \[pmc.ncbi.nlm.nih.gov\]](https://pubmed.ncbi.nlm.nih.gov)
- [6. promega.com \[promega.com\]](https://www.promega.com)
- [7. ulab360.com \[ulab360.com\]](https://www.ulab360.com)
- [8. LanthaScreen® Eu Kinase Binding Assays | Thermo Fisher Scientific - US \[thermofisher.com\]](https://www.thermofisher.com)

- [9. documents.thermofisher.com \[documents.thermofisher.com\]](https://documents.thermofisher.com)
- [10. The ALK inhibitor ceritinib overcomes crizotinib resistance in non-small cell lung cancer - PMC \[pmc.ncbi.nlm.nih.gov\]](https://pubmed.ncbi.nlm.nih.gov/)
- [11. Crizotinib: A comprehensive review - PMC \[pmc.ncbi.nlm.nih.gov\]](https://pubmed.ncbi.nlm.nih.gov/)
- [12. ulab360.com \[ulab360.com\]](https://www.ulab360.com)
- [13. The activity, safety, and evolving role of brigatinib in patients with ALK-rearranged non-small cell lung cancers - PMC \[pmc.ncbi.nlm.nih.gov\]](https://pubmed.ncbi.nlm.nih.gov/)
- [14. benchchem.com \[benchchem.com\]](https://www.benchchem.com)
- [15. Activity of Brigatinib in Crizotinib and Ceritinib-Resistant ROS1- Rearranged Non-Small-Cell Lung Cancer - PMC \[pmc.ncbi.nlm.nih.gov\]](https://pubmed.ncbi.nlm.nih.gov/)
- To cite this document: BenchChem. [A Comparative Guide to CEP-28122: A Selective ALK Inhibitor]. BenchChem, [2026]. [Online PDF]. Available at: [\[https://www.benchchem.com/product/b10762211/docs#a-comparative-guide-to-cep-28122-a-selective-alk-inhibitor\]](https://www.benchchem.com/product/b10762211/docs#a-comparative-guide-to-cep-28122-a-selective-alk-inhibitor)

---

### Disclaimer & Data Validity:

The information provided in this document is for Research Use Only (RUO) and is strictly not intended for diagnostic or therapeutic procedures. While BenchChem strives to provide accurate protocols, we make no warranties, express or implied, regarding the fitness of this product for every specific experimental setup.

**Technical Support:** The protocols provided are for reference purposes. Unsure if this reagent suits your experiment?

**Need Industrial/Bulk Grade?** [Request Custom Synthesis Quote](#)

## BenchChem

Our mission is to be the trusted global source of essential and advanced chemicals, empowering scientists and researchers to drive progress in science and industry.

### Contact

Address: 3281 E Guasti Rd  
Ontario, CA 91761, United States  
Phone: (601) 213-4426  
Email: [info@benchchem.com](mailto:info@benchchem.com)

Contact our Ph.D. Support Team for a compatibility check