

Technical Support Center: Flow Cytometry with Riviciclib-Treated Cells

Author: BenchChem Technical Support Team. **Date:** April 2026

Compound of Interest

Compound Name:	Riviciclib
CAS No.:	920113-02-6
Cat. No.:	B10761812

[Get Quote](#)

Welcome to the technical support center for optimizing flow cytometry settings for cells treated with **Riviciclib**. This resource provides troubleshooting guides and frequently asked questions (FAQs) to help researchers, scientists, and drug development professionals obtain high-quality, reproducible data.

Frequently Asked Questions (FAQs)

Q1: What is the expected effect of **Riviciclib** on the cell cycle?

A1: **Riviciclib** is a potent inhibitor of cyclin-dependent kinases (CDKs), primarily CDK1, CDK4, and CDK9.^{[1][2]} Its mechanism of action involves blocking the phosphorylation of the retinoblastoma (Rb) protein, which prevents the release of E2F transcription factors necessary for the G1 to S phase transition.^{[3][4]} Consequently, treatment with **Riviciclib** is expected to induce cell cycle arrest in the G1 phase.^{[3][5]}

Q2: How does **Riviciclib** treatment affect apoptosis?

A2: In addition to inducing cell cycle arrest, **Riviciclib** has been shown to induce apoptosis in various cancer cell lines.^[1] Therefore, an increase in the apoptotic cell population is an

expected outcome following treatment.

Q3: What are the key flow cytometry assays for evaluating the effects of **Rivaciclib**?

A3: The two primary flow cytometry assays for assessing the cellular response to **Rivaciclib** treatment are:

- **Cell Cycle Analysis:** To quantify the proportion of cells in different phases of the cell cycle (G0/G1, S, and G2/M). This is typically performed using DNA intercalating dyes like Propidium Iodide (PI) or DAPI.[6]
- **Apoptosis Assay:** To measure the percentage of apoptotic and necrotic cells. The most common method is Annexin V and PI co-staining.[7][8]

Q4: Should I use live or fixed cells for my analysis?

A4: The choice between live and fixed cells depends on the assay. For cell cycle analysis using PI, cells are typically fixed with ethanol to permeabilize the membrane and allow the dye to enter and stain the DNA.[6] For apoptosis assays using Annexin V, it is crucial to use live, unfixed cells, as fixation can compromise membrane integrity and lead to inaccurate results.[9]

Troubleshooting Guides

Issue 1: No significant increase in the G1 population after Rivaciclib treatment.

Possible Cause	Recommended Solution
Ineffective Drug Concentration	Perform a dose-response experiment to determine the optimal concentration of Riviciclib for your specific cell line. The IC50 can vary between cell types.[1]
Insufficient Incubation Time	Conduct a time-course experiment to identify the optimal treatment duration for inducing G1 arrest.
Drug Instability	Ensure proper storage and handling of Riviciclib. Prepare fresh solutions for each experiment.
Cell Line Resistance	Some cell lines may be inherently resistant to CDK4/6 inhibitors.[10] Confirm the expression of key pathway components like Rb and CDK4/6 in your cell line.
Incorrect Staining Protocol	Review your cell fixation and PI staining protocol. Ensure complete RNase treatment to avoid RNA staining, which can interfere with DNA content analysis.

Issue 2: High background fluorescence in the flow cytometry data.

Possible Cause	Recommended Solution
Excessive Antibody/Dye Concentration	Titrate your antibodies (e.g., for apoptosis assays) and DNA dyes to determine the optimal concentration that provides a good signal-to-noise ratio. [11]
Inadequate Washing Steps	Increase the number of wash steps after staining to remove unbound antibodies or excess dye. [12]
Cell Debris	Gate out cell debris based on forward and side scatter properties. If necessary, filter the cell suspension through a cell strainer before analysis. [11]
Autofluorescence	Include an unstained control to assess the level of cellular autofluorescence. If high, consider using fluorochromes that emit in the red spectrum to minimize its impact. [13]
Non-specific Antibody Binding	For apoptosis assays, use an isotype control to check for non-specific binding. Additionally, block Fc receptors with reagents like BSA or Fc block. [13]

Issue 3: Poor resolution of cell cycle phases (high Coefficient of Variation - CV).

Possible Cause	Recommended Solution
Cell Clumping	Ensure a single-cell suspension by gently pipetting or passing the sample through a cell strainer. Avoid vigorous vortexing.[11] Use doublet discrimination gating during data analysis.
High Flow Rate	Run samples at a low flow rate to ensure accurate measurement of fluorescence for each cell.[6]
Improper Fixation	Add cold ethanol dropwise while vortexing gently to prevent cell aggregation during fixation.[11]
Instrument Misalignment	Run calibration beads (e.g., flow check beads) to ensure the lasers are properly aligned.[14]

Experimental Protocols

Protocol 1: Cell Cycle Analysis of Riviciclib-Treated Cells using Propidium Iodide

- **Cell Treatment:** Seed cells at an appropriate density and allow them to adhere overnight. Treat the cells with the desired concentration of **Riviciclib** or a vehicle control (e.g., DMSO) for the predetermined duration.
- **Cell Harvesting:** Collect both adherent and floating cells. Centrifuge at 300 x g for 5 minutes.
- **Washing:** Wash the cell pellet once with ice-cold PBS.
- **Fixation:** Resuspend the cell pellet in 100 μ L of PBS. While gently vortexing, add 900 μ L of ice-cold 70% ethanol dropwise.
- **Incubation:** Incubate the cells on ice or at -20°C for at least 30 minutes.
- **Rehydration and Staining:** Centrifuge the fixed cells and discard the ethanol. Wash the pellet with PBS. Resuspend the cells in a staining solution containing Propidium Iodide (e.g., 50

µg/mL) and RNase A (e.g., 100 µg/mL) in PBS.

- Incubation: Incubate at room temperature for 30 minutes in the dark.
- Data Acquisition: Analyze the samples on a flow cytometer using a linear scale for the DNA content channel. Collect data for at least 10,000 events per sample.
- Data Analysis: Use cell cycle analysis software to model the G0/G1, S, and G2/M populations.

Protocol 2: Apoptosis Assay of Riviciclib-Treated Cells using Annexin V and PI

- Cell Treatment: Treat cells with **Riviciclib** or a vehicle control as described in the cell cycle protocol.
- Cell Harvesting: Collect the cell culture supernatant (containing floating cells) and detach the adherent cells using a gentle method like trypsin-EDTA. Combine the floating and adherent cells.
- Washing: Wash the cells twice with cold PBS.
- Resuspension: Resuspend the cell pellet in 1X Annexin V Binding Buffer at a concentration of 1×10^6 cells/mL.
- Staining: Transfer 100 µL of the cell suspension to a new tube. Add 5 µL of fluorochrome-conjugated Annexin V and 5 µL of Propidium Iodide solution.
- Incubation: Gently vortex the cells and incubate for 15 minutes at room temperature in the dark.
- Dilution: Add 400 µL of 1X Annexin V Binding Buffer to each tube.
- Data Acquisition: Analyze the samples immediately on a flow cytometer.
- Data Analysis:
 - Annexin V-negative and PI-negative: Live cells

- Annexin V-positive and PI-negative: Early apoptotic cells
- Annexin V-positive and PI-positive: Late apoptotic/necrotic cells
- Annexin V-negative and PI-positive: Necrotic cells

Data Presentation

Table 1: Expected Cell Cycle Distribution in Cancer Cells Treated with **Rivaciclib**

Treatment	% of Cells in G0/G1	% of Cells in S	% of Cells in G2/M
Vehicle Control	55%	30%	15%
Rivaciclib (IC50)	75%	10%	15%

Table 2: Expected Apoptosis Profile in Cancer Cells Treated with **Rivaciclib**

Treatment	% Live Cells	% Early Apoptotic Cells	% Late Apoptotic/Necrotic Cells
Vehicle Control	90%	5%	5%
Rivaciclib (IC50)	60%	25%	15%

Visualizations

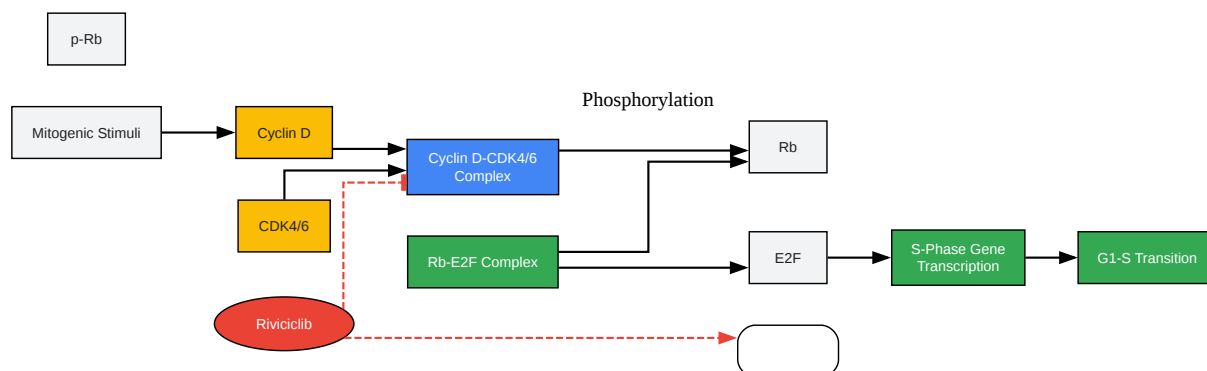

[Click to download full resolution via product page](#)

Caption: **Riviciclib** inhibits the Cyclin D-CDK4/6 complex, preventing Rb phosphorylation and causing G1 cell cycle arrest.

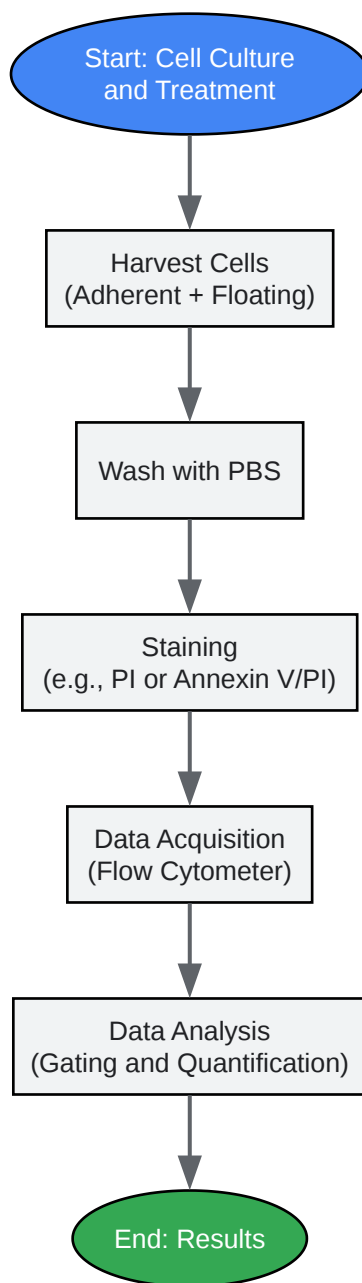

[Click to download full resolution via product page](#)

Caption: General experimental workflow for flow cytometry analysis of **Riviciclib**-treated cells.

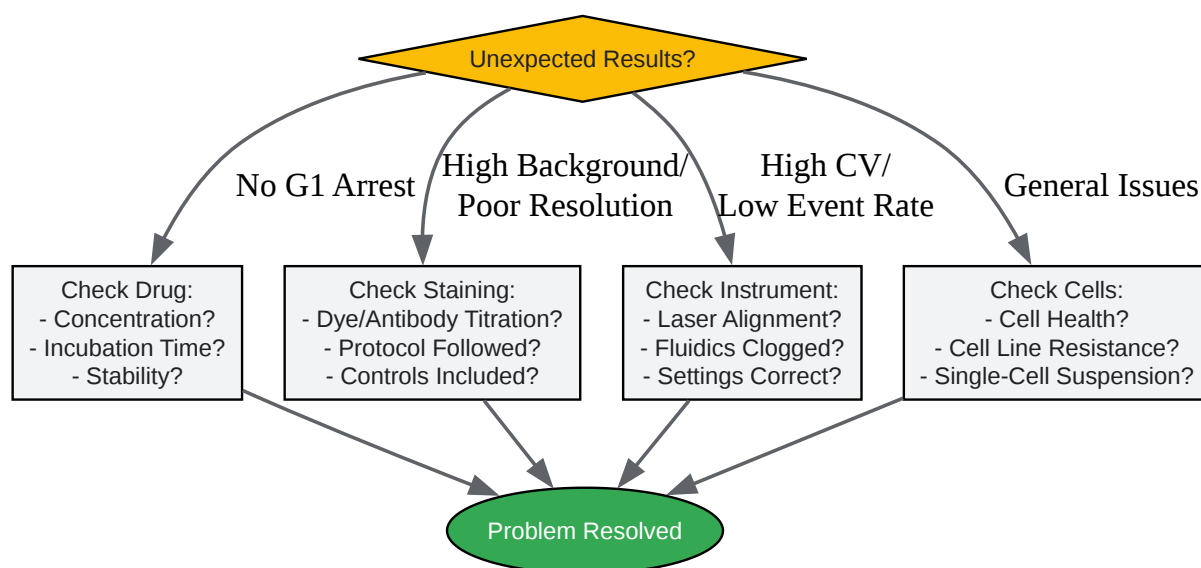

[Click to download full resolution via product page](#)

Caption: A logical troubleshooting guide for common issues in flow cytometry experiments with **Rivaciclib**.

Need Custom Synthesis?

BenchChem offers custom synthesis for rare earth carbides and specific isotopic labeling.

Email: info@benchchem.com or [Request Quote Online](#).

References

- [1. selleckchem.com](http://selleckchem.com) [selleckchem.com]
- [2. medchemexpress.com](http://medchemexpress.com) [medchemexpress.com]
- [3. What is the mechanism of Ribociclib Succinate?](http://synapse.patsnap.com) [synapse.patsnap.com]
- [4. What is the mechanism of action of Ribociclib Succinate?](http://synapse.patsnap.com) [synapse.patsnap.com]
- [5. Flow cytometry-assisted quantification of cell cycle arrest in cancer cells treated with CDK4/6 inhibitors - PubMed](https://pubmed.ncbi.nlm.nih.gov) [pubmed.ncbi.nlm.nih.gov]
- [6. cancer.wisc.edu](http://cancer.wisc.edu) [cancer.wisc.edu]

- [7. Protocol for Apoptosis Assay by Flow Cytometry Using Annexin V Staining Method - PMC \[pmc.ncbi.nlm.nih.gov\]](#)
- [8. Annexin V and PI Staining Protocol for Apoptosis by Flow Cytometry | Bio-Techne \[bio-techne.com\]](#)
- [9. BestProtocols: Annexin V Staining Protocol for Flow Cytometry | Thermo Fisher Scientific - KR \[thermofisher.com\]](#)
- [10. Ribociclib \(LEE011\): mechanism of action and clinical impact of this selective cyclin-dependent kinase 4/6 inhibitor in various solid tumors - PMC \[pmc.ncbi.nlm.nih.gov\]](#)
- [11. Assaying cell cycle status using flow cytometry - PMC \[pmc.ncbi.nlm.nih.gov\]](#)
- [12. Flow Cytometry Troubleshooting Guide | Cell Signaling Technology \[cellsignal.com\]](#)
- [13. bosterbio.com \[bosterbio.com\]](#)
- [14. Flow cytometry troubleshooting | Abcam \[abcam.com\]](#)
- To cite this document: BenchChem. [Technical Support Center: Flow Cytometry with Rivociclib-Treated Cells]. BenchChem, [2026]. [Online PDF]. Available at: [\[https://www.benchchem.com/product/b10761812/docs#technical-support-center-flow-cytometry-with-rivociclib-treated-cells\]](https://www.benchchem.com/product/b10761812/docs#technical-support-center-flow-cytometry-with-rivociclib-treated-cells)

Disclaimer & Data Validity:

The information provided in this document is for Research Use Only (RUO) and is strictly not intended for diagnostic or therapeutic procedures. While BenchChem strives to provide accurate protocols, we make no warranties, express or implied, regarding the fitness of this product for every specific experimental setup.

Technical Support: The protocols provided are for reference purposes. Unsure if this reagent suits your experiment?

Need Industrial/Bulk Grade? [Request Custom Synthesis Quote](#)

BenchChem

Our mission is to be the trusted global source of essential and advanced chemicals, empowering scientists and researchers to drive progress in science and industry.

Contact

Address: 3281 E Guasti Rd

Ontario, CA 91761, United States

Phone: (601) 213-4426

Email: info@benchchem.com

[Contact our Ph.D. Support Team for a compatibility check](#)