

Application Notes and Protocols for Chemosensitivity Assays Using Zosuquidar Trihydrochloride

Author: BenchChem Technical Support Team. **Date:** April 2026

Compound of Interest

Compound Name: Zosuquidar trihydrochloride

Cat. No.: B10761894

[Get Quote](#)

For Researchers, Scientists, and Drug Development Professionals

These application notes provide a comprehensive guide to utilizing **Zosuquidar trihydrochloride** in chemosensitivity assays. Zosuquidar is a potent and specific third-generation inhibitor of P-glycoprotein (P-gp/ABCB1), a primary mediator of multidrug resistance (MDR) in cancer cells.[1][2][3] By blocking the P-gp efflux pump, Zosuquidar restores the intracellular concentration and efficacy of a wide range of chemotherapeutic agents.[1][2]

Mechanism of Action

Zosuquidar trihydrochloride is a non-competitive inhibitor of P-glycoprotein.[4] It binds to the transporter, preventing the efflux of cytotoxic drugs from the cancer cell. This leads to increased intracellular drug accumulation and restores the sensitivity of resistant cells to chemotherapy.[2] Notably, Zosuquidar does not significantly inhibit other ABC transporters like MRP1, MRP2, or BCRP at concentrations effective for P-gp inhibition.[5][6]

Signaling Pathway and Drug Efflux Inhibition

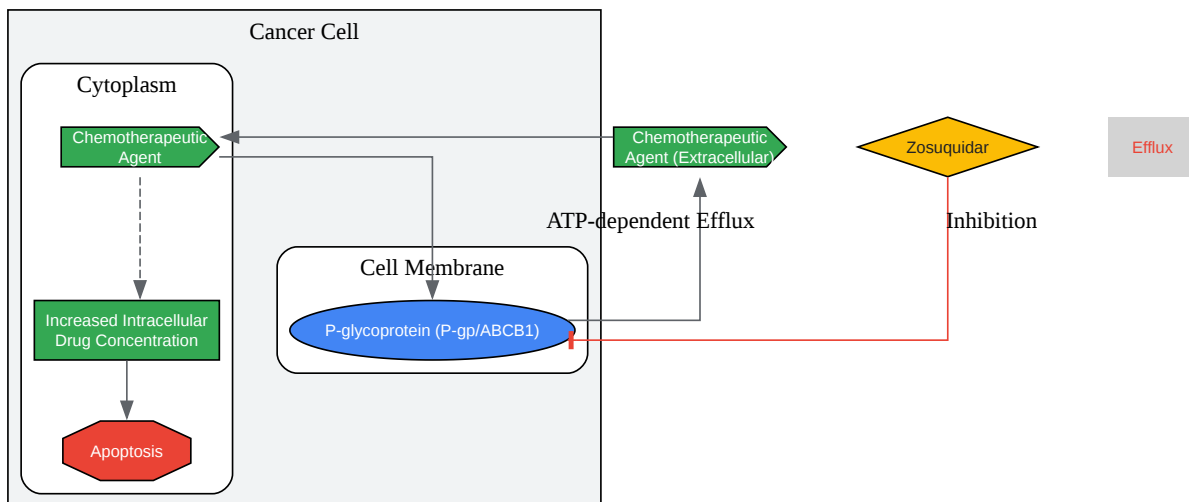

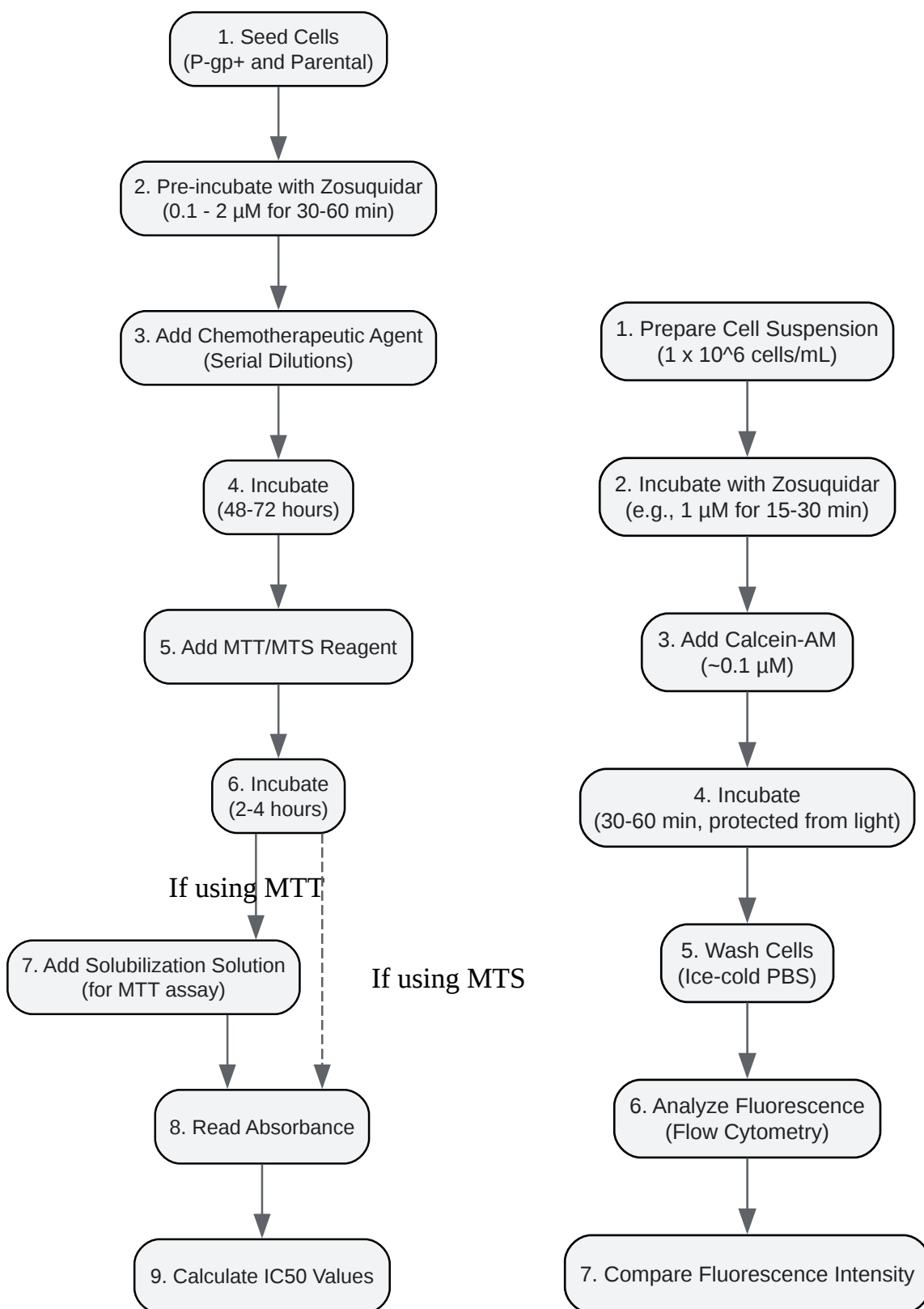

[Click to download full resolution via product page](#)

Need Custom Synthesis?

BenchChem offers custom synthesis for rare earth carbides and specific isotopic labeling.

Email: info@benchchem.com or [Request Quote Online](#).

References

- [1. biotin-hpdp.com](https://biotin-hpdp.com) [biotin-hpdp.com]
- [2. dntp-mixture.com](https://dntp-mixture.com) [dntp-mixture.com]
- [3. benchchem.com](https://benchchem.com) [benchchem.com]
- [4. \[PDF\] Modulation of P-glycoprotein by zosuquidar trihydrochloride. | Semantic Scholar](#) [semanticscholar.org]
- [5. aacrjournals.org](https://aacrjournals.org) [aacrjournals.org]
- [6. The “specific” P-glycoprotein inhibitor zosuquidar \(LY335979\) also weakly inhibits human organic cation transporters - PMC](#) [pmc.ncbi.nlm.nih.gov]
- To cite this document: BenchChem. [Application Notes and Protocols for Chemosensitivity Assays Using Zosuquidar Trihydrochloride]. BenchChem, [2026]. [Online PDF]. Available at: [<https://www.benchchem.com/product/b10761894/docs#application-notes-and-protocols-for-chemosensitivity-assays-using-zosuquidar-trihydrochloride>]

Disclaimer & Data Validity:

The information provided in this document is for Research Use Only (RUO) and is strictly not intended for diagnostic or therapeutic procedures. While BenchChem strives to provide accurate protocols, we make no warranties, express or implied, regarding the fitness of this product for every specific experimental setup.

Technical Support: The protocols provided are for reference purposes. Unsure if this reagent suits your experiment?

Need Industrial/Bulk Grade? [Request Custom Synthesis Quote](#)

BenchChem

Our mission is to be the trusted global source of essential and advanced chemicals, empowering scientists and researchers to drive progress in science and industry.

Contact

Address: 3281 E Guasti Rd
Ontario, CA 91761, United States
Phone: (601) 213-4426
Email: info@benchchem.com

[Contact our Ph.D. Support Team for a compatibility check](#)