

Application Notes and Protocols: Topical Microbicide Gel Formulation of Maraviroc

Author: BenchChem Technical Support Team. **Date:** April 2026

Compound of Interest

Compound Name: Maraviroc
CAS No.: 2414315-81-2
Cat. No.: B10761220

[Get Quote](#)

For Researchers, Scientists, and Drug Development Professionals

These application notes provide a comprehensive overview of a topical microbicide gel formulation containing **Maraviroc**, a CCR5 antagonist for the prevention of HIV-1 transmission. The notes include detailed experimental protocols, quantitative data from preclinical studies, and visualizations of the relevant biological pathway and experimental workflow.

Introduction

Maraviroc is a member of a class of antiretroviral drugs known as C-C chemokine receptor type 5 (CCR5) antagonists.[1][2] It functions by blocking the CCR5 co-receptor on the surface of host cells, which is essential for the entry of R5-tropic strains of HIV-1.[1][2] The development of a topical microbicide gel containing **Maraviroc** represents a promising strategy for pre-exposure prophylaxis (PrEP) against sexually transmitted HIV-1 infection.[3][4][5] This approach aims to deliver the drug directly to the site of potential viral entry, maximizing local concentrations while minimizing systemic absorption and associated side effects.[6]

Mechanism of Action: HIV-1 Entry Inhibition

Maraviroc allosterically binds to the CCR5 co-receptor, inducing a conformational change that prevents the viral envelope glycoprotein gp120 from interacting with it.[7] This blockage of the gp120-CCR5 interaction is a critical step in preventing the fusion of the viral and host cell membranes, thereby inhibiting viral entry.[2] R5-tropic viruses are the predominant strains found in early stages of HIV infection, making CCR5 an important target for prevention.[1]

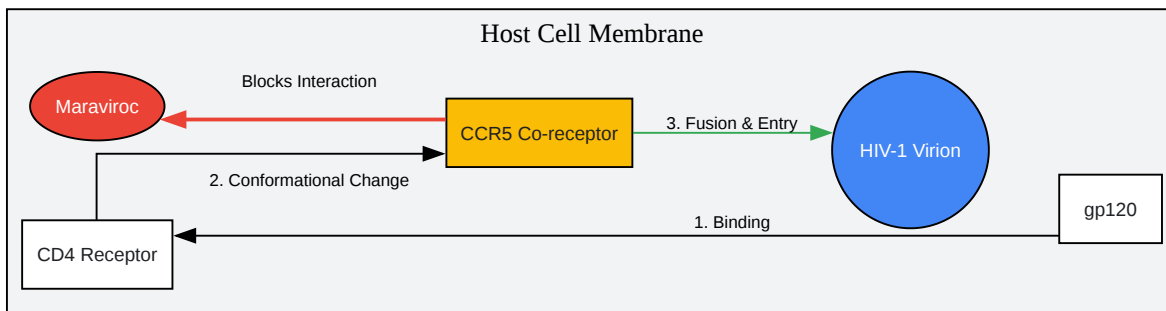

Mechanism of Maraviroc Action

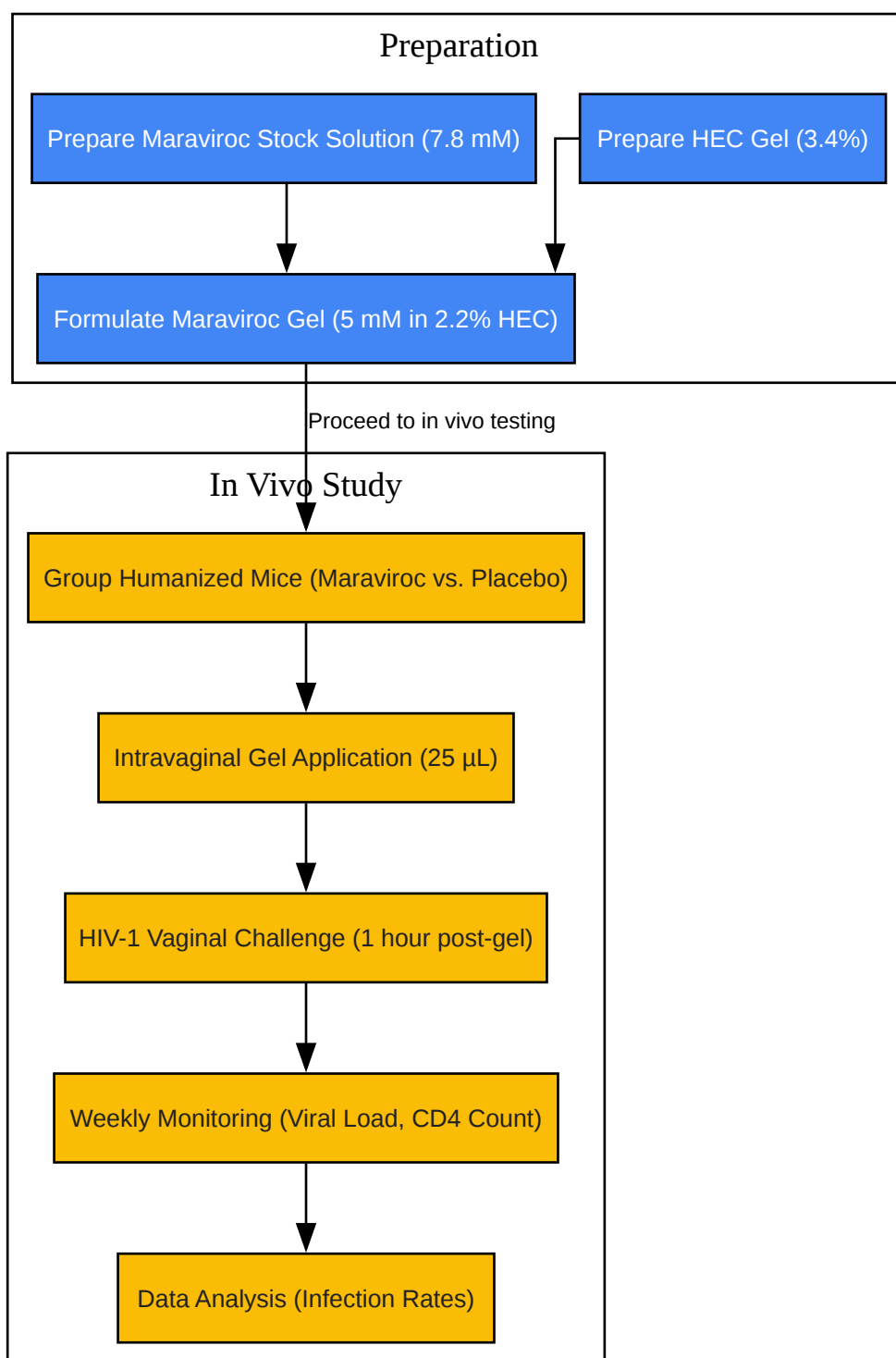

[Click to download full resolution via product page](#)

Need Custom Synthesis?

BenchChem offers custom synthesis for rare earth carbides and specific isotopic labeling.

Email: info@benchchem.com or [Request Quote Online](#).

References

- 1. Maraviroc: a review of its use in HIV infection and beyond - PMC [[pmc.ncbi.nlm.nih.gov](https://pubmed.ncbi.nlm.nih.gov/)]
- 2. Maraviroc in the treatment of HIV infection - PMC [[pmc.ncbi.nlm.nih.gov](https://pubmed.ncbi.nlm.nih.gov/)]
- 3. A Topical Microbicide Gel Formulation of CCR5 Antagonist Maraviroc Prevents HIV-1 Vaginal Transmission in Humanized RAG-hu Mice - PMC [[pmc.ncbi.nlm.nih.gov](https://pubmed.ncbi.nlm.nih.gov/)]
- 4. A Topical Microbicide Gel Formulation of CCR5 Antagonist Maraviroc Prevents HIV-1 Vaginal Transmission in Humanized RAG-hu Mice | PLOS One [journals.plos.org]
- 5. A topical microbicide gel formulation of CCR5 antagonist maraviroc prevents HIV-1 vaginal transmission in humanized RAG-hu mice - PubMed [pubmed.ncbi.nlm.nih.gov]
- 6. Formulation, pharmacokinetics and pharmacodynamics of topical microbicides - PMC [[pmc.ncbi.nlm.nih.gov](https://pubmed.ncbi.nlm.nih.gov/)]
- 7. Structure of the CCR5 chemokine receptor-HIV entry inhibitor maraviroc complex - PubMed [pubmed.ncbi.nlm.nih.gov]
- To cite this document: BenchChem. [Application Notes and Protocols: Topical Microbicide Gel Formulation of Maraviroc]. BenchChem, [2026]. [Online PDF]. Available at: [<https://www.benchchem.com/product/b10761220/docs#application-notes-and-protocols-topical-microbicide-gel-formulation-of-maraviroc>]

Disclaimer & Data Validity:

The information provided in this document is for Research Use Only (RUO) and is strictly not intended for diagnostic or therapeutic procedures. While BenchChem strives to provide accurate protocols, we make no warranties, express or implied, regarding the fitness of this product for every specific experimental setup.

Technical Support: The protocols provided are for reference purposes. Unsure if this reagent suits your experiment?

Need Industrial/Bulk Grade? [Request Custom Synthesis Quote](#)

BenchChem

Our mission is to be the trusted global source of essential and advanced chemicals, empowering scientists and researchers to drive progress in science and industry.

Contact

Address: 3281 E Guasti Rd
Ontario, CA 91761, United States
Phone: (601) 213-4426
Email: info@benchchem.com

[Contact our Ph.D. Support Team for a compatibility check](#)