

(Z)-SU14813: A Technical Guide for Researchers and Drug Development Professionals

Author: BenchChem Technical Support Team. **Date:** April 2026

Compound of Interest

Compound Name: (Z)-SU14813

Cat. No.: B10752407

[Get Quote](#)

An In-depth Analysis of the Structure, Chemical Properties, and Biological Activity of a Potent Multi-Targeted Receptor Tyrosine Kinase Inhibitor

For research use only. Not for use in humans.

Introduction

(Z)-SU14813 is a potent, orally active, multi-targeted receptor tyrosine kinase (RTK) inhibitor.[1] It has demonstrated significant anti-angiogenic and antitumor activity by targeting key signaling pathways involved in tumor growth, proliferation, and metastasis. This technical guide provides a comprehensive overview of the chemical structure, physicochemical properties, mechanism of action, and key experimental protocols related to **(Z)-SU14813**, intended for researchers, scientists, and professionals in the field of drug development.

Chemical Structure and Properties

(Z)-SU14813 is a synthetic organic small molecule. Its chemical structure is characterized by a substituted 1H-pyrrole-3-carboxamide core linked to a fluoro-indolin-2-one moiety.

Chemical Structure:

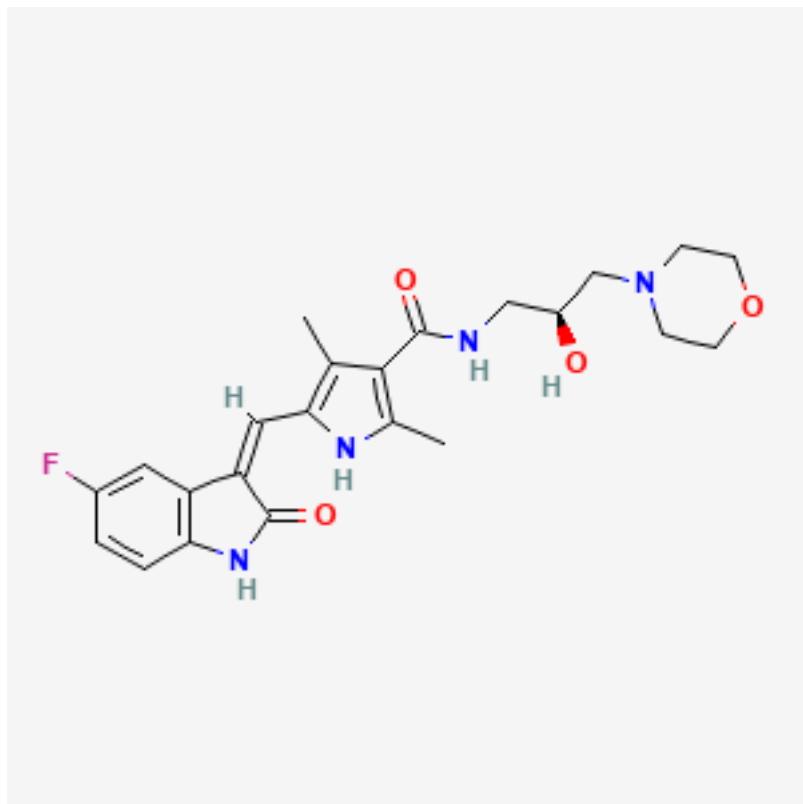

Table 1: Chemical Identifiers and Properties of **(Z)-SU14813**

Property	Value	Source
IUPAC Name	5-[(Z)-(5-fluoro-2-oxo-1H-indol-3-ylidene)methyl]-N-[(2S)-2-hydroxy-3-morpholin-4-ylpropyl]-2,4-dimethyl-1H-pyrrole-3-carboxamide	[2]
Chemical Formula	C ₂₃ H ₂₇ FN ₄ O ₄	[2]
Molecular Weight	442.48 g/mol	[3][4]
CAS Number	627908-92-3	[3][5]
SMILES	<chem>CC1=C(NC(=C1C(=O)NC--INVALID-LINK--O)C)/C=C\3/C4=C(C=CC(=C4)F)NC3=O</chem>	[2]
Boiling Point	685.6 ± 55.0 °C at 760 mmHg	[4]
Melting Point	Not available	
pKa	Not available	

Table 2: Solubility Profile of **(Z)-SU14813**

Solvent	Solubility	Notes	Source
DMSO	≥15.26 mg/mL	Can be up to 88 mg/mL in fresh, non-hygroscopic DMSO. Ultrasonic treatment may be needed.	[3][5]
Ethanol	Insoluble	[5]	
Water	Insoluble	[5]	
In Vivo Formulation 1	≥ 2.5 mg/mL	10% DMSO, 40% PEG300, 5% Tween-80, 45% Saline	[6]
In Vivo Formulation 2	≥ 2.5 mg/mL	10% DMSO, 90% Corn Oil	[6]

Storage and Stability:

(Z)-SU14813 powder should be stored at -20°C for up to 3 years. Stock solutions in DMSO can be stored at -80°C for up to 1 year. To avoid repeated freeze-thaw cycles, it is recommended to aliquot stock solutions.[3]

Mechanism of Action and Signaling Pathways

(Z)-SU14813 exerts its biological effects by inhibiting multiple receptor tyrosine kinases, thereby blocking downstream signaling cascades crucial for cell proliferation and angiogenesis.

Target Kinases:

(Z)-SU14813 is a potent inhibitor of the following receptor tyrosine kinases, with IC₅₀ values indicating high affinity:

Table 3: Inhibitory Activity of **(Z)-SU14813** against Target Kinases

Target Kinase	IC ₅₀ (nM)	Source
VEGFR1	2	[3][7]
PDGFR β	4	[3][7]
c-Kit	15	[3][7]
VEGFR2	50	[3][7]

By inhibiting these kinases, **(Z)-SU14813** disrupts critical signaling pathways, including the VEGFR, PDGFR, and c-Kit pathways.

VEGFR Signaling Pathway Inhibition

The Vascular Endothelial Growth Factor (VEGF) signaling pathway is a primary driver of angiogenesis. **(Z)-SU14813**'s inhibition of VEGFR1 and VEGFR2 blocks the downstream effects of VEGF, leading to a reduction in endothelial cell proliferation, migration, and new blood vessel formation in tumors.

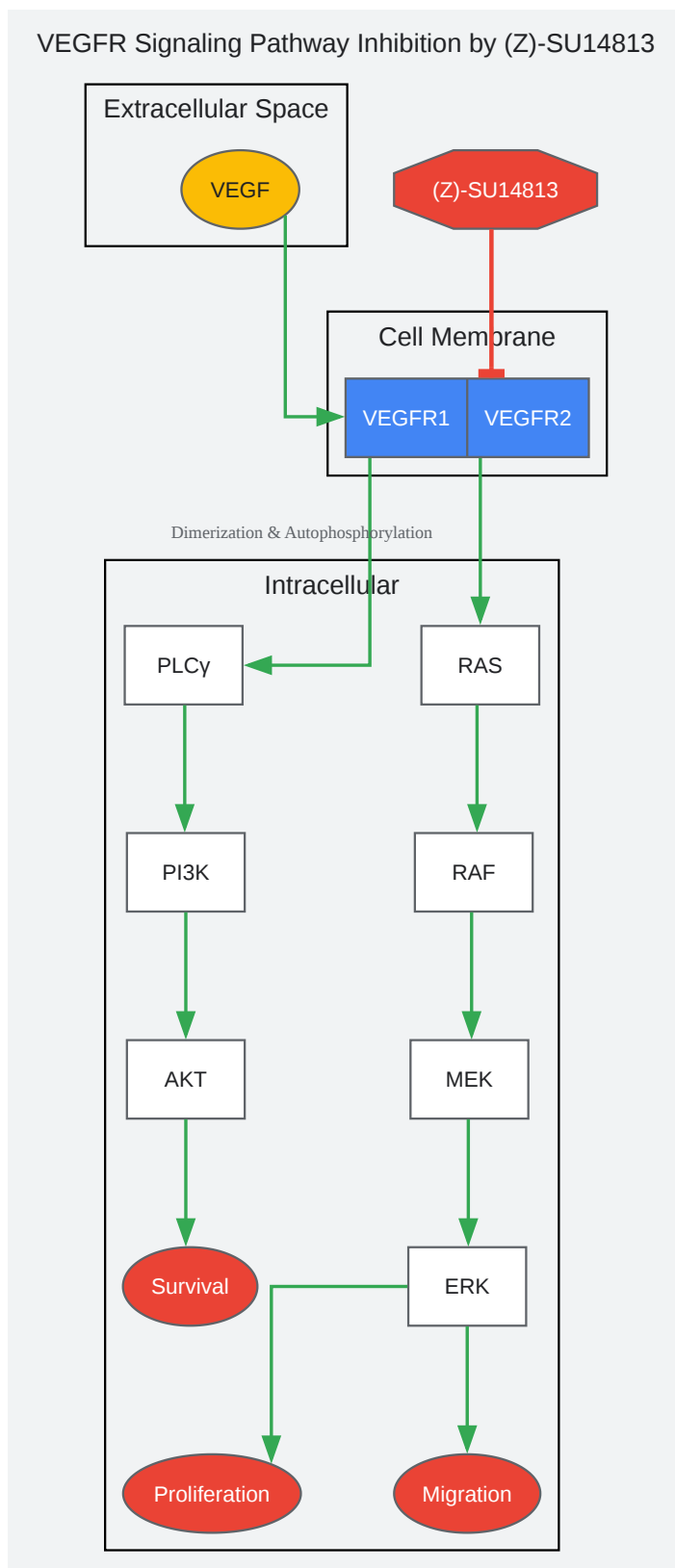

[Click to download full resolution via product page](#)

Caption: Inhibition of VEGFR signaling by **(Z)-SU14813**.

PDGFR Signaling Pathway Inhibition

The Platelet-Derived Growth Factor (PDGF) signaling pathway is involved in cell growth, proliferation, and differentiation. By inhibiting PDGFR β , **(Z)-SU14813** can impede the growth of tumor cells that overexpress this receptor.

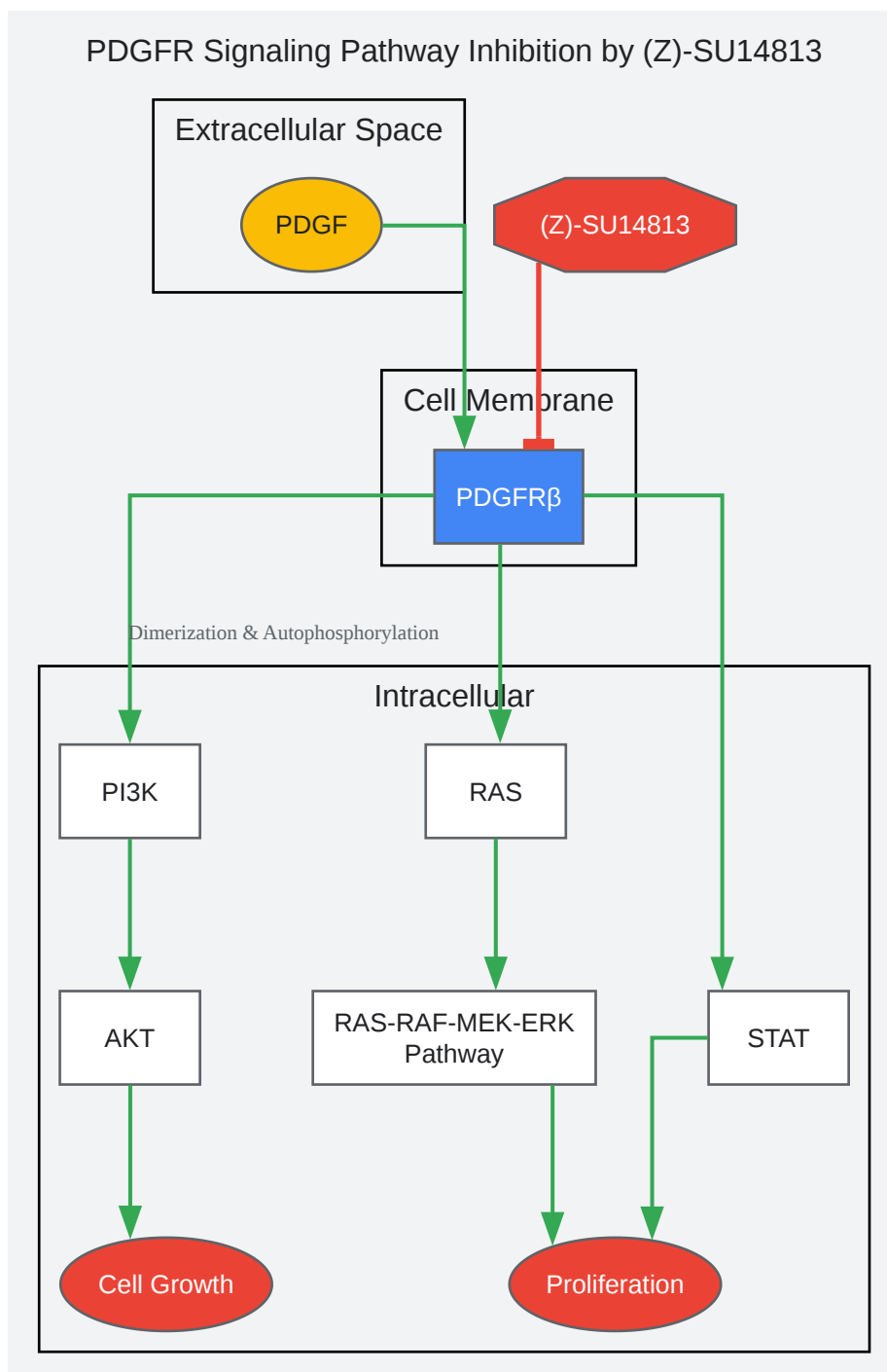

[Click to download full resolution via product page](#)

Caption: Inhibition of PDGFR signaling by **(Z)-SU14813**.

c-Kit Signaling Pathway Inhibition

The c-Kit receptor tyrosine kinase is crucial for the development and proliferation of certain cell types, including hematopoietic stem cells and mast cells. Aberrant c-Kit signaling is implicated in various cancers. **(Z)-SU14813**'s inhibition of c-Kit can lead to apoptosis in cancer cells dependent on this pathway.

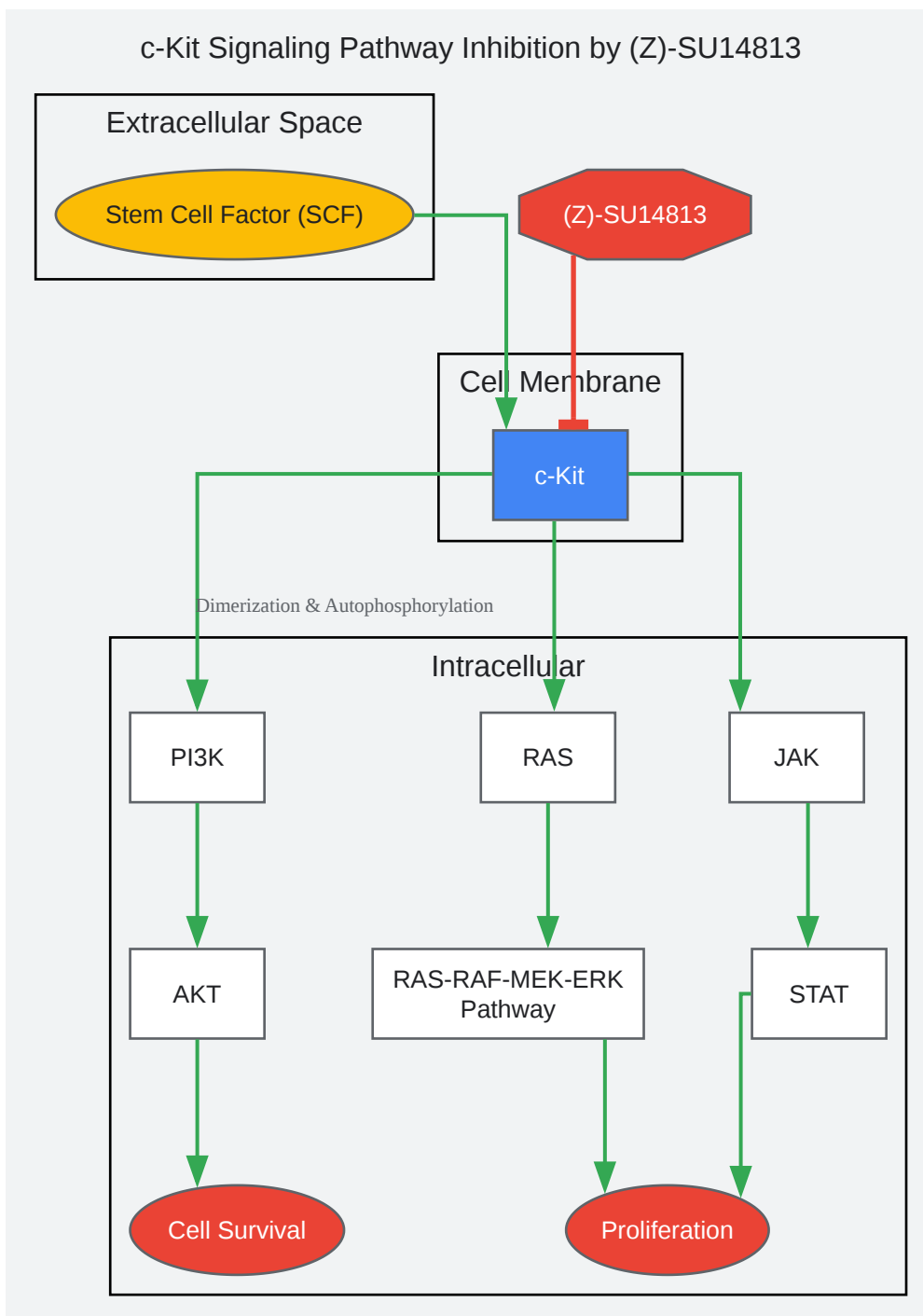

[Click to download full resolution via product page](#)

Caption: Inhibition of c-Kit signaling by **(Z)-SU14813**.

Experimental Protocols

Detailed methodologies for key experiments involving **(Z)-SU14813** are provided below. These protocols are based on previously published research and serve as a guide for in vitro and in vivo studies.

Biochemical Kinase Assay

This assay determines the in vitro inhibitory activity of **(Z)-SU14813** against purified kinase domains.

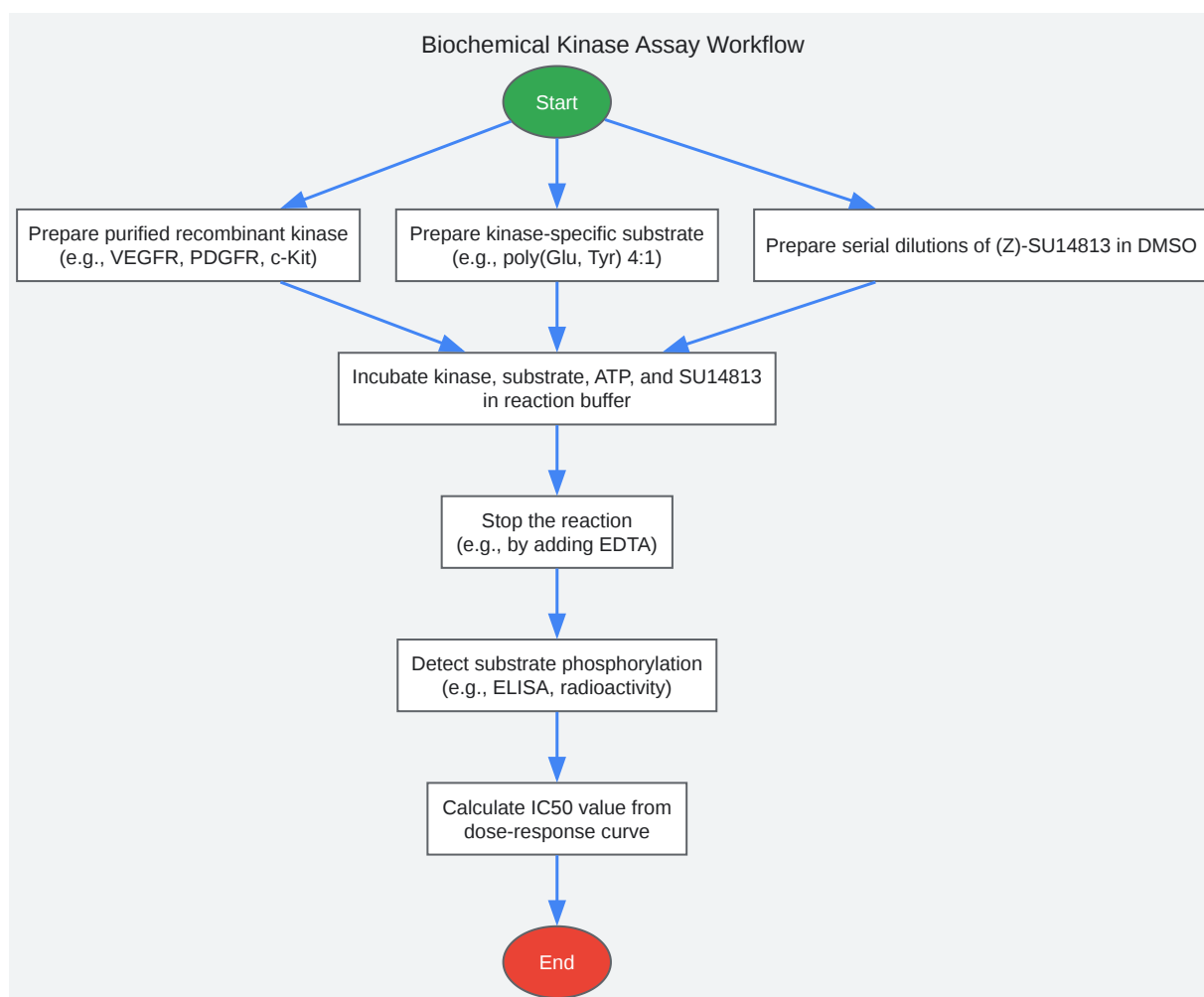

[Click to download full resolution via product page](#)

Caption: Workflow for a typical biochemical kinase assay.

Detailed Protocol:

- Preparation of Reagents:
 - Prepare a stock solution of **(Z)-SU14813** in 100% DMSO.
 - Perform serial dilutions of the stock solution to obtain a range of concentrations.
 - Prepare a reaction buffer containing ATP and the specific kinase substrate.
 - Dilute the purified kinase to the desired concentration in kinase buffer.
- Assay Procedure:
 - Add the diluted **(Z)-SU14813** or DMSO (vehicle control) to the wells of a microtiter plate.
 - Add the kinase and substrate to the wells.
 - Initiate the reaction by adding ATP.
 - Incubate the plate at a controlled temperature (e.g., 30°C) for a specific duration.
- Detection and Analysis:
 - Stop the reaction.
 - Measure the level of substrate phosphorylation using a suitable detection method.
 - Plot the percentage of inhibition against the logarithm of the **(Z)-SU14813** concentration.
 - Determine the IC₅₀ value using non-linear regression analysis.

Cellular Receptor Phosphorylation Assay

This assay measures the ability of **(Z)-SU14813** to inhibit the phosphorylation of its target receptors within a cellular context.

Detailed Protocol:

- Cell Culture and Treatment:
 - Culture cells expressing the target receptor (e.g., HUVECs for VEGFR, engineered NIH-3T3 cells for PDGFR) to sub-confluency.
 - Starve the cells in a low-serum medium for several hours to reduce basal receptor phosphorylation.
 - Treat the cells with various concentrations of **(Z)-SU14813** for a specified pre-incubation period.
- Ligand Stimulation:
 - Stimulate the cells with the appropriate ligand (e.g., VEGF for VEGFR, PDGF for PDGFR) for a short period to induce receptor phosphorylation.
- Cell Lysis and Protein Analysis:
 - Wash the cells with cold PBS and lyse them in a suitable lysis buffer containing protease and phosphatase inhibitors.
 - Determine the protein concentration of the lysates.
 - Separate the proteins by SDS-PAGE and transfer them to a membrane (Western blotting).
 - Probe the membrane with primary antibodies specific for the phosphorylated form of the target receptor and the total form of the receptor.
 - Use a secondary antibody conjugated to a detectable enzyme (e.g., HRP) and visualize the bands using a chemiluminescent substrate.
- Data Analysis:

- Quantify the band intensities and normalize the phosphorylated receptor levels to the total receptor levels.
- Calculate the percentage of inhibition of phosphorylation at each concentration of **(Z)-SU14813** and determine the IC₅₀ value.

Cell Proliferation Assay

This assay evaluates the effect of **(Z)-SU14813** on the proliferation of cancer cell lines or endothelial cells.

Detailed Protocol:

- Cell Seeding:
 - Seed the cells in a 96-well plate at a predetermined density and allow them to adhere overnight.
- Compound Treatment:
 - Treat the cells with a range of concentrations of **(Z)-SU14813**. Include a vehicle control (DMSO).
- Incubation:
 - Incubate the cells for a period that allows for several cell divisions (e.g., 48-72 hours).
- Measurement of Cell Proliferation:
 - Use a suitable method to quantify cell viability or proliferation, such as:
 - MTT Assay: Measures the metabolic activity of viable cells.
 - BrdU Incorporation Assay: Measures DNA synthesis in proliferating cells.
 - Cell Counting: Direct counting of cells using a hemocytometer or an automated cell counter.
- Data Analysis:

- Calculate the percentage of inhibition of cell proliferation for each concentration of **(Z)-SU14813**.
- Determine the GI₅₀ (concentration for 50% of maximal inhibition of cell proliferation) by plotting the percentage of inhibition against the log of the compound concentration.

Conclusion

(Z)-SU14813 is a valuable research tool for investigating the roles of VEGFR, PDGFR, and c-Kit signaling in cancer and other diseases. Its potent and multi-targeted inhibitory profile provides a strong rationale for its use in preclinical studies aimed at developing novel anti-angiogenic and anti-cancer therapies. This guide provides essential technical information to support the design and execution of such research.

Need Custom Synthesis?

BenchChem offers custom synthesis for rare earth carbides and specific isotopic labeling.

Email: info@benchchem.com or [Request Quote Online](#).

References

- [1. SU14813: a novel multiple receptor tyrosine kinase inhibitor with potent antiangiogenic and antitumor activity - PubMed \[pubmed.ncbi.nlm.nih.gov\]](#)
- [2. medchemexpress.com \[medchemexpress.com\]](#)
- [3. selleckchem.com \[selleckchem.com\]](#)
- [4. researchgate.net \[researchgate.net\]](#)
- [5. selleck.co.jp \[selleck.co.jp\]](#)
- [6. medchemexpress.com \[medchemexpress.com\]](#)
- [7. Su-14813 | C23H27FN4O4 | CID 10138259 - PubChem \[pubchem.ncbi.nlm.nih.gov\]](#)
- To cite this document: BenchChem. [(Z)-SU14813: A Technical Guide for Researchers and Drug Development Professionals]. BenchChem, [2026]. [Online PDF]. Available at: [\[https://www.benchchem.com/product/b10752407/docs#z-su14813-a-technical-guide-for-researchers-and-drug-development-professionals\]](https://www.benchchem.com/product/b10752407/docs#z-su14813-a-technical-guide-for-researchers-and-drug-development-professionals)

Disclaimer & Data Validity:

The information provided in this document is for Research Use Only (RUO) and is strictly not intended for diagnostic or therapeutic procedures. While BenchChem strives to provide accurate protocols, we make no warranties, express or implied, regarding the fitness of this product for every specific experimental setup.

Technical Support: The protocols provided are for reference purposes. Unsure if this reagent suits your experiment?

Need Industrial/Bulk Grade? [Request Custom Synthesis Quote](#)

BenchChem

Our mission is to be the trusted global source of essential and advanced chemicals, empowering scientists and researchers to drive progress in science and industry.

Contact

Address: 3281 E Guasti Rd
Ontario, CA 91761, United States
Phone: (601) 213-4426
Email: info@benchchem.com

[Contact our Ph.D. Support Team for a compatibility check](#)