

(Z)-SU14813: A Comprehensive Technical Guide on its Mechanism of Action

Author: BenchChem Technical Support Team. **Date:** April 2026

Compound of Interest

Compound Name: (Z)-SU14813

Cat. No.: B10752453

[Get Quote](#)

For Researchers, Scientists, and Drug Development Professionals

Abstract

(Z)-SU14813 is a potent, orally bioavailable, multi-targeted receptor tyrosine kinase (RTK) inhibitor. Exhibiting significant anti-angiogenic and anti-tumor properties, its mechanism of action is centered on the inhibition of several key RTKs implicated in tumor growth, proliferation, and angiogenesis. This technical guide provides an in-depth analysis of the core mechanism of action of **(Z)-SU14813**, presenting quantitative data on its inhibitory activities, detailed experimental protocols for its characterization, and visual representations of the signaling pathways it modulates.

Core Mechanism of Action

(Z)-SU14813 exerts its therapeutic effects by selectively targeting and inhibiting the catalytic activity of multiple split kinase domain RTKs. Its primary targets include Vascular Endothelial Growth Factor Receptors (VEGFRs), Platelet-Derived Growth Factor Receptors (PDGFRs), Stem Cell Factor Receptor (KIT), and FMS-like Tyrosine Kinase 3 (FLT3)[1][2]. By binding to the ATP-binding pocket of these receptors, SU14813 blocks their autophosphorylation and subsequent activation of downstream signaling cascades. This multi-pronged approach allows

for the simultaneous disruption of critical pathways involved in tumor angiogenesis, tumor cell proliferation, and survival[1][2][3].

Quantitative Inhibitory Activity

The inhibitory potency of **(Z)-SU14813** against its key targets has been quantified through various biochemical and cellular assays. The half-maximal inhibitory concentration (IC50) values are summarized below.

Table 1: Biochemical Kinase Inhibition by (Z)-SU14813

Target Kinase	IC50 (nM)
VEGFR1 (Flt-1)	2[4][5]
VEGFR2 (KDR/Flk-1)	50[4][5]
PDGFR β	4[4][5]
KIT	15[4][5]
FLT3	Data not consistently reported in nM, but potent inhibition is confirmed.

Table 2: Cellular Inhibitory Activity of (Z)-SU14813

Cell Line/Target	Assay	IC50 (nM)
Porcine Aortic Endothelial Cells (VEGFR-2)	Receptor Phosphorylation	5.2[4]
Porcine Aortic Endothelial Cells (PDGFR β)	Receptor Phosphorylation	9.9[4]
Porcine Aortic Endothelial Cells (KIT)	Receptor Phosphorylation	11.2[4]
Human Umbilical Vein Endothelial Cells (HUVEC)	VEGF-stimulated survival	6.8
U-118MG (glioblastoma)	Growth Inhibition	50-100[4]

Key Signaling Pathways Modulated by (Z)-SU14813

(Z)-SU14813's inhibition of VEGFR, PDGFR, KIT, and FLT3 disrupts several downstream signaling pathways crucial for cancer progression. The primary pathways affected are the RAS/MAPK, PI3K/AKT, and STAT signaling cascades.

VEGFR Signaling Pathway

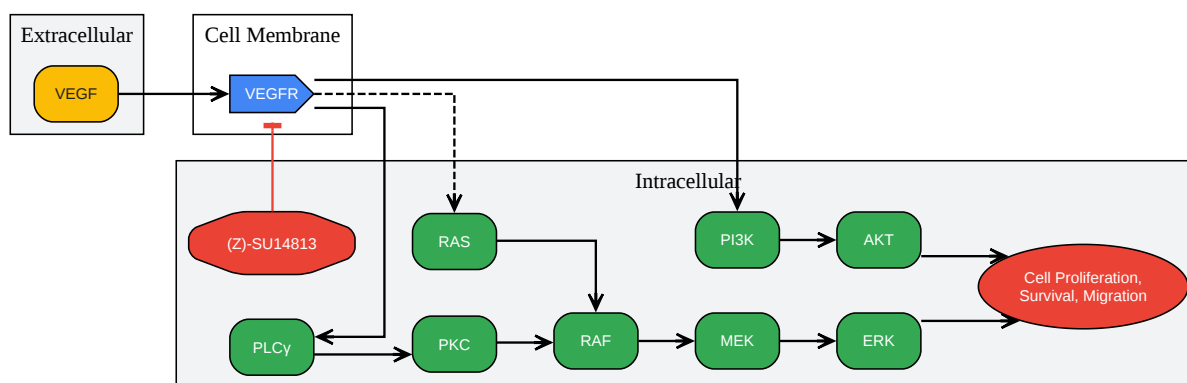

[Click to download full resolution via product page](#)

Caption: (Z)-SU14813 inhibits VEGFR, blocking downstream signaling through PLCγ/PKC/MAPK and PI3K/AKT pathways.

PDGFR Signaling Pathway

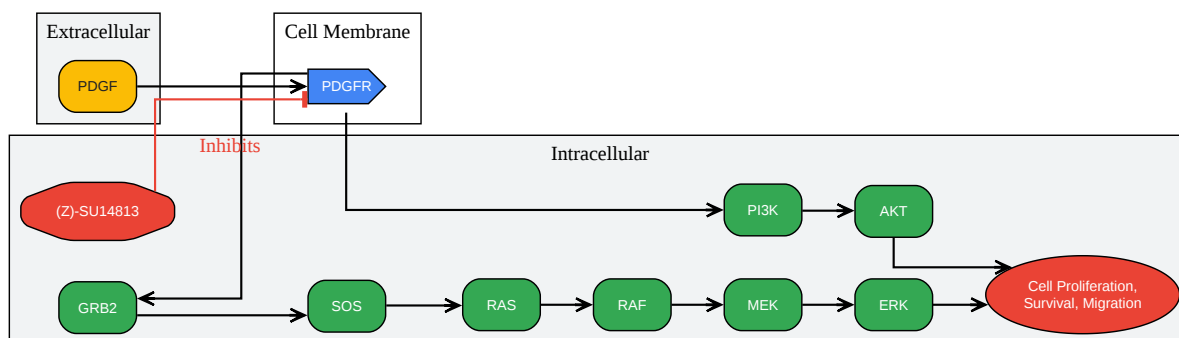

[Click to download full resolution via product page](#)

Caption: **(Z)-SU14813** inhibits PDGFR, blocking downstream signaling through RAS/MAPK and PI3K/AKT pathways.

KIT and FLT3 Signaling Pathways

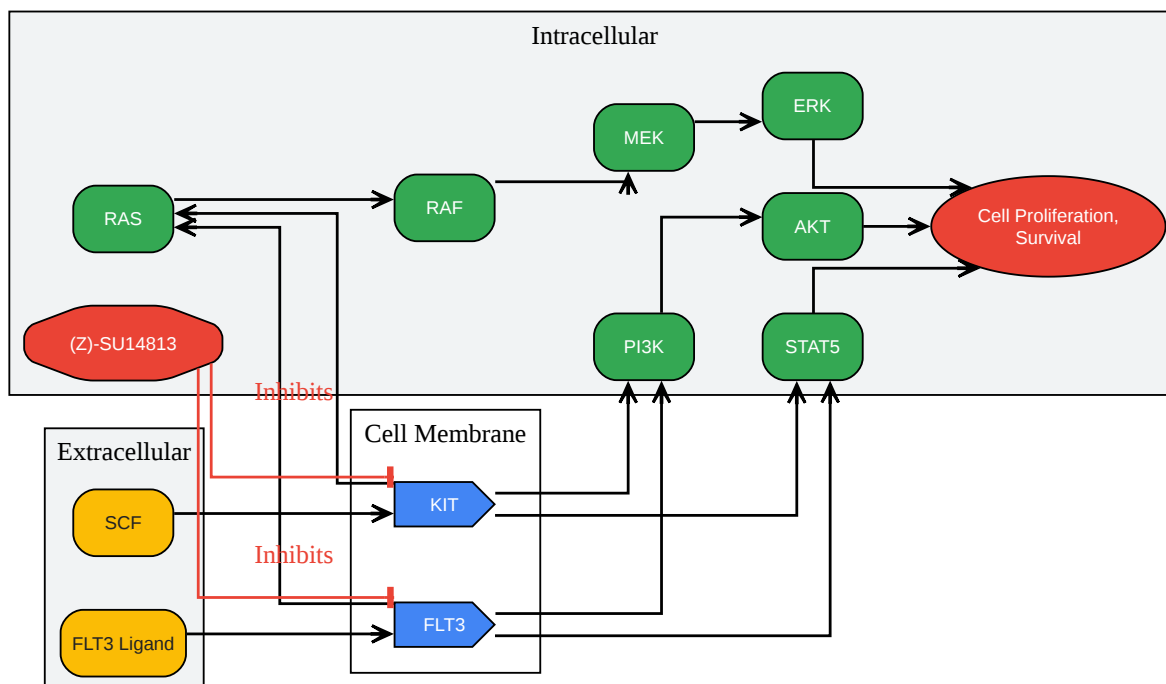

[Click to download full resolution via product page](#)

Caption: **(Z)-SU14813** inhibits KIT and FLT3, blocking downstream signaling through RAS/MAPK, PI3K/AKT, and STAT5.

Detailed Experimental Protocols

The following sections outline the methodologies for key experiments used to characterize the mechanism of action of **(Z)-SU14813**.

Biochemical Kinase Assay

- Objective: To determine the in vitro inhibitory activity of **(Z)-SU14813** against purified kinase domains.

- Methodology:
 - Recombinant human kinase domains (e.g., VEGFR-2, PDGFR β , KIT, FLT3) are expressed as fusion proteins (e.g., GST-fusion) and purified.
 - The kinase reaction is initiated in a buffer containing the purified kinase, a specific substrate (e.g., poly(Glu, Tyr) 4:1), and ATP (often radiolabeled [γ - 32 P]ATP).
 - **(Z)-SU14813** is added at various concentrations to determine its effect on kinase activity.
 - The reaction is incubated at a controlled temperature (e.g., 30°C) for a defined period.
 - The reaction is stopped, and the amount of phosphorylated substrate is quantified. This can be achieved by methods such as scintillation counting for radiolabeled ATP or by using specific antibodies in an ELISA-based format.
 - IC50 values are calculated by plotting the percentage of kinase inhibition against the log concentration of **(Z)-SU14813** and fitting the data to a sigmoidal dose-response curve.

Cellular Receptor Phosphorylation Assay

- Objective: To assess the ability of **(Z)-SU14813** to inhibit ligand-induced receptor phosphorylation in a cellular context.
- Methodology:
 - Cells overexpressing the target receptor (e.g., NIH-3T3 cells transfected with VEGFR-2 or PDGFR β) are cultured to sub-confluency.
 - Cells are serum-starved for a period (e.g., 18-24 hours) to reduce basal receptor phosphorylation.
 - Cells are pre-incubated with varying concentrations of **(Z)-SU14813** for a defined time (e.g., 1-2 hours).
 - The respective ligand (e.g., VEGF for VEGFR-2, PDGF for PDGFR β) is added to stimulate receptor autophosphorylation.

- After a short incubation with the ligand (e.g., 5-10 minutes), cells are lysed.
- The total amount of the target receptor and its phosphorylated form are determined by Western blotting or ELISA using specific antibodies.
- The level of phosphorylated receptor is normalized to the total amount of the receptor.
- IC50 values are determined by plotting the percentage of inhibition of phosphorylation against the log concentration of **(Z)-SU14813**.

HUVEC Survival Assay

- Objective: To evaluate the effect of **(Z)-SU14813** on endothelial cell survival stimulated by growth factors.
- Methodology:
 - Human Umbilical Vein Endothelial Cells (HUVECs) are seeded in 96-well plates and allowed to adhere.
 - Cells are then starved in a low-serum medium (e.g., 1% FBS) for 18-24 hours.
 - **(Z)-SU14813** is added at various concentrations, followed by the addition of a pro-survival growth factor such as VEGF. A control group with a non-targeted growth factor like bFGF can be included to assess specificity.
 - Cells are incubated for a period of 2-3 days.
 - Cell viability is assessed using a colorimetric assay such as the MTT (3-(4,5-dimethylthiazol-2-yl)-2,5-diphenyltetrazolium bromide) assay. The absorbance is read on a plate reader.
 - The percentage of cell survival is calculated relative to the vehicle-treated control.
 - IC50 values are determined from the dose-response curve.

In Vivo Tumor Xenograft Model

- Objective: To assess the anti-tumor efficacy of **(Z)-SU14813** in a living organism.
- Methodology:
 - Human tumor cells (e.g., from renal cell carcinoma, colon cancer, or AML cell lines) are cultured and harvested during their exponential growth phase.
 - A specific number of tumor cells (e.g., 1×10^6 to 10×10^6) are suspended in a suitable medium (e.g., PBS or Matrigel) and subcutaneously injected into the flank of immunocompromised mice (e.g., athymic nude or SCID mice).
 - Tumors are allowed to grow to a palpable size (e.g., 100-200 mm³).
 - Mice are then randomized into treatment and control groups.
 - **(Z)-SU14813** is administered orally at various doses (e.g., 10-80 mg/kg) on a defined schedule (e.g., once or twice daily). The control group receives the vehicle.
 - Tumor volume is measured regularly (e.g., 2-3 times per week) using calipers. Tumor volume is calculated using the formula: $(\text{Length} \times \text{Width}^2)/2$.
 - At the end of the study, tumors may be excised for further analysis, such as immunohistochemistry to assess angiogenesis (e.g., CD31 staining) or target receptor phosphorylation.
 - The anti-tumor efficacy is evaluated by comparing the tumor growth inhibition in the treated groups to the control group.

Experimental Workflows

Biochemical Kinase Assay Workflow

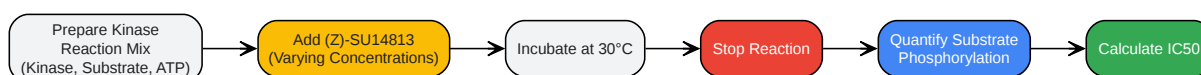

[Click to download full resolution via product page](#)

Caption: Workflow for determining the in vitro inhibitory activity of **(Z)-SU14813**.

In Vivo Xenograft Study Workflow



[Click to download full resolution via product page](#)

Caption: Workflow for evaluating the in vivo anti-tumor efficacy of **(Z)-SU14813**.

Conclusion

(Z)-SU14813 is a multi-targeted RTK inhibitor with a well-defined mechanism of action. Its ability to potently inhibit VEGFR, PDGFR, KIT, and FLT3 translates into significant anti-angiogenic and anti-tumor effects, which have been demonstrated in both in vitro and in vivo preclinical models. The data and experimental protocols presented in this guide provide a comprehensive resource for researchers and drug development professionals working with this and similar targeted therapies. Further investigation into the nuanced downstream effects and potential resistance mechanisms will continue to refine our understanding of this promising therapeutic agent.

Need Custom Synthesis?

BenchChem offers custom synthesis for rare earth carbides and specific isotopic labeling.

Email: info@benchchem.com or [Request Quote Online](#).

References

- 1. Roles of PDGF/PDGFR signaling in various organs - PMC [[pmc.ncbi.nlm.nih.gov](https://pubmed.ncbi.nlm.nih.gov/)]
- 2. Downstream molecular pathways of FLT3 in the pathogenesis of acute myeloid leukemia: biology and therapeutic implications - PMC [[pmc.ncbi.nlm.nih.gov](https://pubmed.ncbi.nlm.nih.gov/)]
- 3. Kit signaling through PI 3-kinase and Src kinase pathways: an essential role for Rac1 and JNK activation in mast cell proliferation - PMC [[pmc.ncbi.nlm.nih.gov](https://pubmed.ncbi.nlm.nih.gov/)]

- [4. Vascular Endothelial Growth Factor \(VEGF\) and Its Receptor \(VEGFR\) Signaling in Angiogenesis: A Crucial Target for Anti- and Pro-Angiogenic Therapies - PMC \[pmc.ncbi.nlm.nih.gov\]](#)
- [5. Comprehensive Dissection of PDGF-PDGFR Signaling Pathways in PDGFR Genetically Defined Cells | PLOS One \[journals.plos.org\]](#)
- To cite this document: BenchChem. [(Z)-SU14813: A Comprehensive Technical Guide on its Mechanism of Action]. BenchChem, [2026]. [Online PDF]. Available at: [\[https://www.benchchem.com/product/b10752453/docs#z-su14813-a-comprehensive-technical-guide-on-its-mechanism-of-action\]](https://www.benchchem.com/product/b10752453/docs#z-su14813-a-comprehensive-technical-guide-on-its-mechanism-of-action)

Disclaimer & Data Validity:

The information provided in this document is for Research Use Only (RUO) and is strictly not intended for diagnostic or therapeutic procedures. While BenchChem strives to provide accurate protocols, we make no warranties, express or implied, regarding the fitness of this product for every specific experimental setup.

Technical Support: The protocols provided are for reference purposes. Unsure if this reagent suits your experiment?

Need Industrial/Bulk Grade? [Request Custom Synthesis Quote](#)

BenchChem

Our mission is to be the trusted global source of essential and advanced chemicals, empowering scientists and researchers to drive progress in science and industry.

Contact

Address: 3281 E Guasti Rd
Ontario, CA 91761, United States
Phone: (601) 213-4426
Email: info@benchchem.com

[Contact our Ph.D. Support Team for a compatibility check](#)

